



CFB600 Series Application Note V22 March 2026

ISOLATED DC-DC CONVERTER CFB600 SERIES APPLICATION NOTE



Approved By:

Department	Approved By	Checked By	Written By
Research and Development Department	Jacky	Danny	Tony
Design Quality Department	Benny	JoJo	



CFB600 Series

Application Note V22 March 2026

Contents

1. Introduction	3
2. DC-DC Converter Features.....	3
3. Electrical Block Diagram	3
4. Technical Specifications.....	4
5. Main Features and Functions.....	7
5.1 <i>Operating Temperature Range</i>	7
5.2 <i>Output Voltage Adjustment</i>	7
5.3 <i>Over Current Protection</i>	7
5.4 <i>Output Over Voltage Protection</i>	7
5.5 <i>Remote On/Off</i>	7
5.6 <i>UVLO&OVLO (Under/Over Voltage Lock Out)</i>	7
5.7 <i>Over Temperature Protection</i>	7
6. Applications.....	7
6.1 <i>Recommended Layout, PCB Footprint and Soldering Information</i>	7
6.2 <i>Convection Requirements for Cooling</i>	8
6.3 <i>Thermal Considerations</i>	8
6.4 <i>Power De-Rating</i>	9
6.5 <i>Full Brick Heat Sinks:</i>	10
6.6 <i>Efficiency VS. Load</i>	11
6.7 <i>Test Set-Up</i>	13
6.8 <i>Output Voltage Adjustment</i>	13
6.9 <i>Output Remote Sensing</i>	14
6.10 <i>Output Ripple and Noise</i>	14
6.11 <i>Output Capacitance</i>	14
6.12 <i>Parallel Operation</i>	14
6.13 <i>IOG Signal</i>	15
6.14 <i>Auxiliary Power for Output Signal</i>	15
6.15 <i>On/Off Control</i>	15
7. Safety & EMC	16
7.1 <i>Input Fusing and Safety Considerations</i>	16
7.2 <i>EMC Considerations</i>	16
8. Part Number.....	18



CFB600 Series

Application Note V22 March 2026

1. Introduction

This specification describes the features and functions of Cincon's CFB600 series of isolated DC-DC Converters. These are highly efficient, reliable and compact, high power density, single output DC/DC converters. The modules can be used in the field of telecommunications, data communications, wireless communications, servers, base station, etc. The CFB600 series can deliver up to 50A output current and provide a precisely regulated output voltage over a wide range of 18-36 and 36-75VDC. The modules can achieve high efficiency up to 92%. The module offers direct cooling of dissipative components for excellent thermal performance. Standard features include isolated remote **on/off** (positive or negative), remote sense, output voltage adjustment, over voltage, over current and over temperature protection. Parallel operation is also optional.

2. DC-DC Converter Features

- 600-700W Isolated Output
- Efficiency to 92%
- Fixed Switching Frequency
- Input Under-Voltage Protection
- Over Temperature Protection
- Over Voltage/Current Protection
- Remote On/Off
- Industry Full-Brick Package
- Fully Isolated 1500VDC
- IEC/EN/UL 62368-1 Approval

3. Electrical Block Diagram

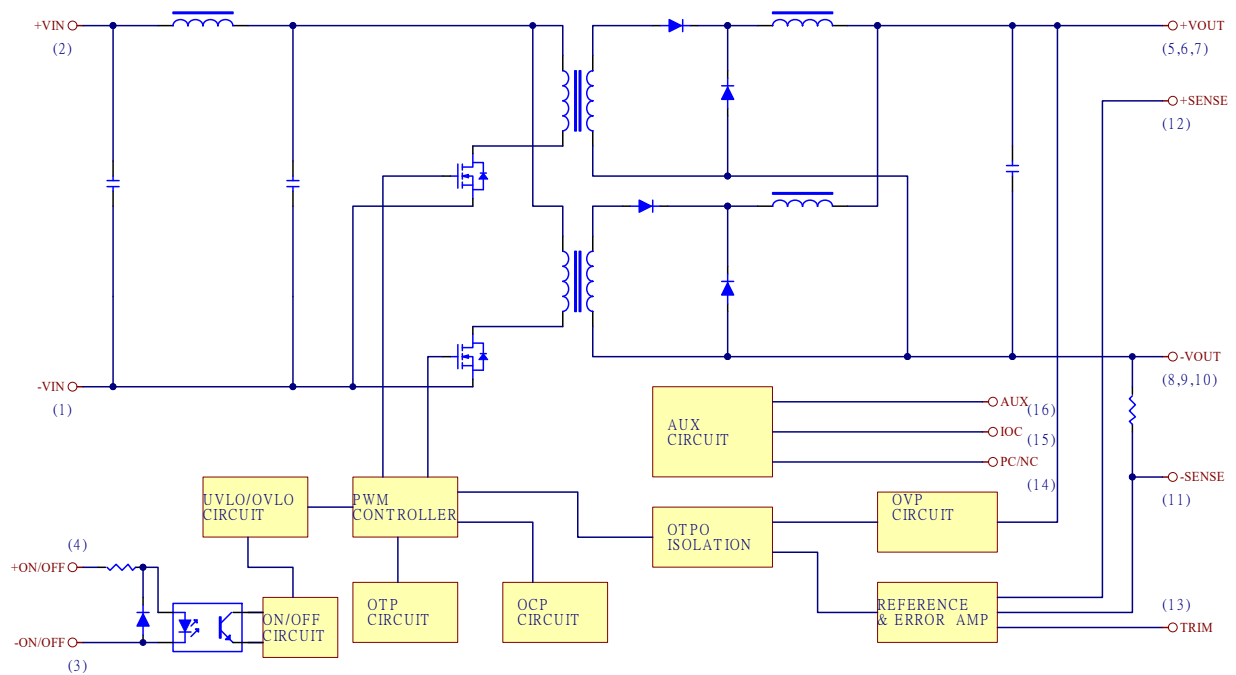

Electrical Block Diagram for CFB600 Series Modules



CFB600 Series

Application Note V22 March 2026

4. Technical Specifications

(All specifications are typical at nominal input, full load at 25°C unless otherwise noted.)

ABSOLUTE MAXIMUM RATINGS

Stresses in excess of the absolute maximum ratings can cause permanent damage to the device. These are absolute stress ratings only, functional operation of the device is not implied at these or any other conditions in excess of those given in the operations sections of the data sheet. Exposure to absolute maximum ratings for extended periods can adversely affect the device reliability.

PARAMETER	NOTES and CONDITIONS	Device	Min.	Typ.	Max.	Units
Input Voltage						
Continuous		24SXX	-0.3		36	V_{dc}
		48SXX	-0.3		75	
Operating Case Temperature		All	-40		100	°C
Storage Temperature		All	-55		105	°C
Isolation Voltage	1 Minute; input/output, input/case, output/case, input/remote, output/remote	All	1500			V_{dc}

INPUT CHARACTERISTICS

PARAMETER	NOTES and CONDITIONS	Device	Min.	Typ.	Max.	Units
Operating Input Voltage		24SXX	18	24	36	V_{dc}
		48SXX	36	48	75	
Input Under Voltage Lockout						
Turn-On Voltage Threshold		24SXX	16	17	18	V_{dc}
		48SXX	34	35	36	
Turn-Off Voltage Threshold		24SXX	15	16	17	V_{dc}
		48SXX	32	33	34	
Lockout Hysteresis Voltage		24SXX		1.0		V_{dc}
		48SXX		2.0		
Input Over Voltage Lockout						
Turn-On Voltage Threshold		24SXX	37	38	39	V_{dc}
		48SXX	76	77	78	
Turn-Off Voltage Threshold		24SXX	39	40	42	V_{dc}
		48SXX	79	80	81	
Lockout Hysteresis Voltage		24SXX		2.0		V_{dc}
		48SXX		3.0		
Maximum Input Current	100% Load, $V_{in}=18V$	24SXX		37.7		A
	100% Load, $V_{in}=36V$	48SXX		21.7		
No-Load Input Current		24S12		150		mA
		24S24		150		
		24S28		150		
		24S32		150		
		24S48		200		
		48S12		90		
		48S24		100		
		48S28		105		
		48S32		90		
		48S48		130		
Inrush Current (I^2t)		All			1.0	A^2s



CFB600 Series

Application Note V22 March 2026

OUTPUT CHARACTERISTICS

PARAMETER	NOTES and CONDITIONS	Device	Min.	Typ.	Max.	Units
Output Voltage Set Point	V_{in} =Nominal V_{in} , $I_o = I_{o_max.}$, $T_c=25^\circ C$	$V_o=12V$	11.88	12.00	12.12	V_{dc}
		$V_o=24V$	23.76	24.00	24.24	
		$V_o=28V$	27.72	28.00	28.28	
		$V_o=32V$	31.68	32.00	32.32	
		$V_o=48V$	47.52	48.00	48.48	
Output Voltage Regulation						
Load Regulation	$I_o=I_{o_min.}$ to $I_{o_max.}$	All			± 0.5	%
Line Regulation	V_{in} =low line to high line	All			± 0.2	%
Temperature Coefficient	$T_c=-40^\circ C$ to $100^\circ C$	All			± 0.03	%/ $^\circ C$
Output Voltage Ripple and Noise						
Peak-to-Peak	20MHz bandwidth, Full load, 10uF tantalum and 1.0uF ceramic capacitors (48V: 10uF aluminum and 1.0uF ceramic capacitors)	$V_o=12V$			120	mV
		$V_o=24V$			240	
		$V_o=28V$			280	
		$V_o=32V$			320	
		$V_o=48V$			480	
RMS	20MHz bandwidth, Full load, 10uF tantalum and 1.0uF ceramic capacitors (48V: 10uF aluminum and 1.0uF ceramic capacitors)	$V_o=12V$			60	mV
		$V_o=24V$			100	
		$V_o=28V$			100	
		$V_o=32V$			120	
		$V_o=48V$			200	
Operating Output Current Range		24S28	0		21.5	A
		48S28	0		25	
		$V_o=12V$	0		50	
		$V_o=24V$	0		25	
		$V_o=32V$	0		19	
$V_o=48V$	0		12.5			
Output DC Current Limit Inception	Output voltage=90% nominal output voltage	All	110		150	%
Power Good Signal (IOG)	V_{out} ready: low level, sink current	All			20	mA
	V_{out} not ready: open drain output, applied voltage				50	V
Output Capacitance	Full load (resistive)	24S32	470		70000	uF
		$V_o=12V$	470		10000	
		Others	470		5000	

DYNAMIC CHARACTERISTICS

PARAMETER	NOTES and CONDITIONS	Device	Min.	Typ.	Max.	Units
Output Voltage Current Transient						
Step Change in Output Current	$d_i/d_t=0.1A/us$, Load change from 75% to 100% to 75% of I_o max.	All		± 3	± 5	%
Setting Time (within 1% V_{out} nominal)	$d_i/d_t=0.1A/us$	All			500	us
Turn-On Delay and Rise Time						
Turn-On Delay Time, From On/Off Control	$V_{on/off}$ to 10% V_{o_set}	All			75	ms
Turn-On Delay Time, From Input	$V_{in_min.}$ to 10% V_{o_set}	All			250	ms
Output Voltage Rise Time	10% V_{o_set} to 90% V_{o_set}	All			50	ms



CFB600 Series

Application Note V22 March 2026

EFFICIENCY

PARAMETER	NOTES and CONDITIONS	Device	Min.	Typ.	Max.	Units
100% Load		24S12		88		%
		24S24		90		
		24S28		90		
		24S32		91		
		24S48		91		
		48S12		90		
		48S24		92		
		48S28		91		
		48S32		92		
		48S48		92		

ISOLATION CHARACTERISTICS

PARAMETER	NOTES and CONDITIONS	Device	Min.	Typ.	Max.	Units
Isolation Voltage	1 Minute; input/output, input/case, output/case, input/remote, output/remote	All			1500	V _{dc}
Isolation Resistance		All	10			MΩ
Isolation Capacitance		All		4000		pF

FEATURE CHARACTERISTICS

PARAMETER	NOTES and CONDITIONS	Device	Min.	Typ.	Max.	Units
Switching Frequency		48S12		300		KHz
		48S28		300		
		48S32		300		
		Others		250		
On/Off Control Negative Remote On/Off Logic						
Logic Low (Module Off)		All	0		0.01	mA
Logic High (Module On)		All	1.0		10	mA
On/Off Control Positive Remote On/Off Logic						
Logic High (Module Off)		All	1.0		10	mA
Logic Low (Module On)		All	0		0.01	mA
Auxiliary Output Voltage		All	7	10	13	V
Auxiliary Output Current		All			20	mA
Load Share Accuracy (50%-100% load)		All	-10		+10	%
Off Converter Input Current	Shutdown input idle current	24S24			60	mA
		24S32				
		24S48				
		24S12			55	
		Others			50	
Output Voltage Trim Range	P _{out} =max rated power	All	60		110	%
Output Over Voltage Protection		All	115	125	140	%
Over-Temperature Shutdown		All		110		°C

GENERAL SPECIFICATIONS

PARAMETER	NOTES and CONDITIONS	Device	Min.	Typ.	Max.	Units
MTBF	I _o =100% of I _{o_max} ; T _a =25°C per MIL-HDBK-217F	All		450		k hours
Weight		All		220		grams



CFB600 Series

Application Note V22 March 2026

5. Main Features and Functions

5.1 Operating Temperature Range

The CFB600 series converters can be operated within a wide case temperature range of -40 °C to 100 °C. Consideration must be given to the de-rating curves when ascertaining maximum power that can be drawn from the converter. The maximum power drawn from full brick models is influenced by usual factors, such as:

- Input voltage range
- Output load current
- Forced air or natural convection

5.2 Output Voltage Adjustment

Section 6.8 describes in detail how to trim the output voltage with respect to its set point. The output voltage on all models is adjustable within the range of 60% to 110%.

5.3 Over Current Protection

The converter is protected against over current or short circuit conditions. At the instance of current-limit inception, the module enters a constant current mode of operation. While the fault condition exists, the module will remain in this constant current mode and can remain in this mode until the fault is cleared. The unit operates normally once the output current is reduced back into its specified range.

5.4 Output Over Voltage Protection

The converter is protected against output over voltage conditions. When the output voltage is higher than the specified range, the module enters a hiccup mode of operation.

5.5 Remote On/Off

The **on/off** input pins permit the user to turn the power module on or off via a system signal from the primary side or the secondary side. Two remote **on/off** options are available. Negative logic turns the module on as long as a current (1-10mA) is flowing between **+on/off** and **-on/off** and inactive when no current is flowing. Positive logic turns the module off as long as a current (1-10mA) is flowing between **+on/off** and **-on/off** and active when no current is flowing.

5.6 UVLO&OVLO (Under/Over Voltage Lock Out)

Input under/over voltage lockout is standard with this converter. At input voltages below/beyond the input under voltage lockout limit, the module operation is disabled.

5.7 Over Temperature Protection

These modules have an over temperature protection circuit to safeguard against thermal damage. When the case temperature rises above over temperature shutdown threshold, the converter will shut down to protect it from overheating. The module will automatically restart after it cools down.

6. Applications

6.1 Recommended Layout, PCB Footprint and Soldering Information

The system designer or end user must ensure that metal and other components in the vicinity of the converter meet the spacing requirements for which the system is approved. Low resistance and inductance PCB layout traces are the norm and should be used where possible. Due consideration must also be given to proper low impedance tracks between power module, input and output grounds. The recommended soldering profile and PCB layout are shown below.

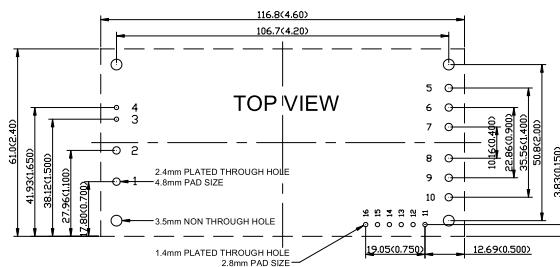

Recommend PCB Pad Layout



CFB600 Series

Application Note V22 March 2026

Lead Free Wave Soldering Profile

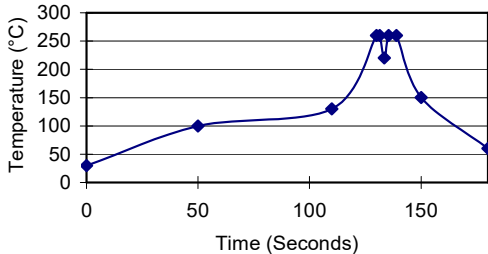

Hand Soldering Information:

Hand soldering is the least preferred method because the amount of solder applied, the time the soldering iron is held on the joint, the temperature of the iron, and the temperature of the solder joint are variable. The recommended hand soldering guideline is listed in following table. The suggested soldering process must keep the power module's internal temperature below the critical temperature of 217°C continuously.

Hand-Soldering Guideline

Parameter	Single-side Circuit board	Double-side Circuit board	Multi-layers Circuit board
Soldering Iron Wattage	90W	90W	90W
Tip Temp.	385+/-10°C	420+/-10°C	420+/-10°C
Soldering Time	2~6 Seconds	4~10 Seconds	4~10 Seconds

The suggested soldering process must keep the power module's internal temperature below the critical temperature of 217°C continuously.

Clean the soldered side of the module with a brush, prevent liquid from getting into the module. Do not clean by soaking the module into liquid. Do not allow solvent to come in contact with product labels or resin case as this may change the color of the resin case or cause deletion of the letters printed on the product label. After cleaning, dry the modules well.

6.2 Convection Requirements for Cooling

To predict the approximate cooling needed for the full brick module, refer to the power de-rating curves in **section 6.4**. These de-rating curves are approximations of the ambient temperatures and airflows required to keep the power module temperature below its maximum rating. Once the module is assembled in the actual system, the module's temperature should be monitored to ensure it does not exceed 100°C as being measured at the center of the top of the case (thus verifying proper cooling).

6.3 Thermal Considerations

The power module operates in a variety of thermal environments; however, sufficient cooling should be provided to help ensure reliable operation of the unit. Heat is removed by conduction, convection, and radiation to the surrounding environment. The test data is presented in **section 6.4**. The power output of the module should not be allowed to exceed rated power ($V_{o_set} \times I_{o_max}$).



CFB600 Series

Application Note V22 March 2026

6.4 Power De-Rating

The operating case temperature range of CFB600 series is -40°C to +100°C. When operating the CFB600 series, proper de-rating or cooling is needed. The maximum case temperature under any operating condition should not be exceeded 100°C.

The following curve is the de-rating curve of CFB600 series without heat sink.

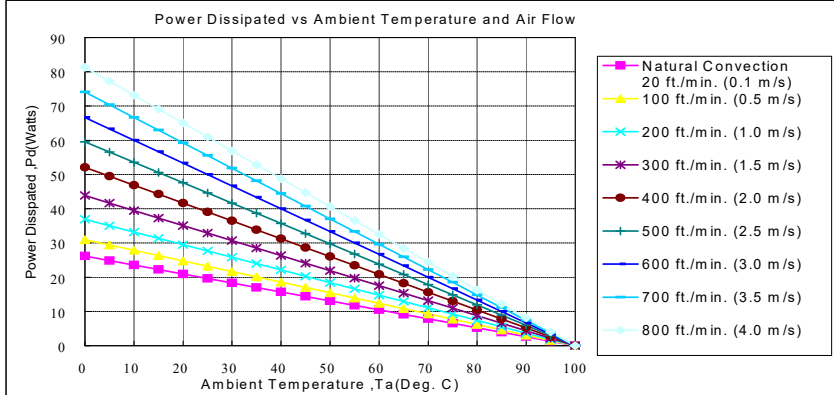

AIR FLOW RATE	TYPICAL R _{ca}
Natural Convection 20ft./min. (0.1m/s)	3.82 °C/W
100 ft./min. (0.5m/s)	3.23 °C/W
200 ft./min. (1.0m/s)	2.71 °C/W
300 ft./min. (1.5m/s)	2.28 °C/W
400 ft./min. (2.0m/s)	1.92 °C/W
500 ft./min. (2.5m/s)	1.68 °C/W
600 ft./min. (3.0m/s)	1.50 °C/W
700 ft./min. (3.5m/s)	1.35 °C/W
800 ft./min. (4.0m/s)	1.23 °C/W

Example:

What is the minimum airflow necessary for a CFB600-48S12 operating at nominal line, an output current of 30A, and a maximum ambient temperature of 40°C

Solution:

Given: $V_{in}=48V_{dc}$, $V_o=12V_{dc}$, $I_o=30A$

Determine power dissipation (P_d):

$$P_d = P_i - P_o = P_o(1-\eta)/\eta$$

$$P_d = 12 \times 30 \times (1-0.9)/0.9 = 40 \text{ Watts}$$

Determine airflow:

Given: $P_d=40W$ and $T_a=40^\circ C$

Check above power de-rating curve:

minimum airflow= 700 ft./min.

Verifying: The maximum temperature rise

$$\Delta T = P_d \times R_{ca} = 40 \times 1.35 = 54^\circ C$$

The maximum case temperature $T_c = T_a + \Delta T = 94^\circ C < 100^\circ C$

Where:

The R_{ca} is thermal resistance from case to ambience

The T_a is ambient temperature and the T_c is case temperature

Chart of Thermal Resistance vs Air Flow



CFB600 Series

Application Note V22 March 2026

The following curve is the de-rating curve of CFB600 series with heat sink FBL254 (M-B012).

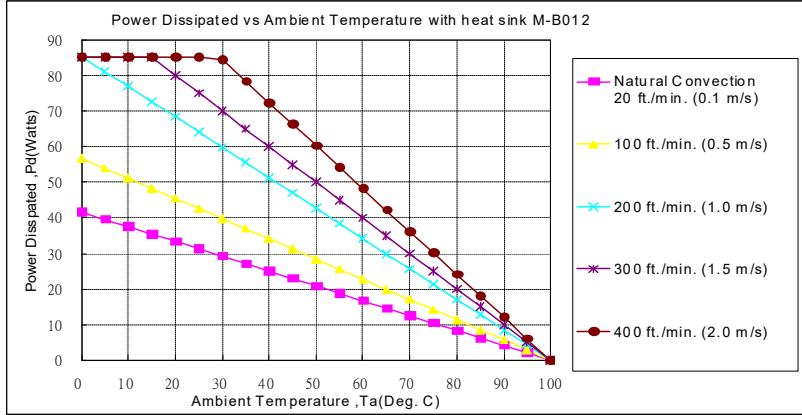

AIR FLOW RATE	TYPICAL R _{ca}
Natural Convection 20ft./min. (0.1m/s)	2.4 °C/W
100 ft./min. (0.5m/s)	1.76 °C/W
200 ft./min. (1.0m/s)	1.17 °C/W
300 ft./min. (1.5m/s)	1.00 °C/W
400 ft./min. (2.0m/s)	0.83 °C/W

Forced Convection Power De-rating with Heat Sink FBL254 (M-B012)

Example:

What is the minimum airflow necessary for a CFB600-48S12 operating at nominal line, an output current of 50A, and a maximum ambient temperature of 40°C

Solution:

Given: $V_{in}=48V_{dc}$, $V_o=12V_{dc}$, $I_o=50A$

Determine power dissipation (P_d):

$$P_d = P_i - P_o = P_o(1 - \eta) / \eta$$

$$P_d = 12 \times 50 \times (1 - 0.9) / 0.9 = 66.7 \text{ Watts (Chart of Thermal Resistance vs Air Flow)}$$

Determine airflow:

Given: $P_d=66.7W$ and $T_a=40^\circ C$

Check above power de-rating curve:

minimum airflow= 400 ft./min.

Verifying:

The maximum temperature rise $\Delta T = P_d \times R_{ca} = 66.7 \times 0.83 = 55.4^\circ C$

The maximum case temperature $T_c = T_a + \Delta T = 95.4^\circ C < 100^\circ C$

Where:

The R_{ca} is thermal resistance from case to ambience

The T_a is ambient temperature and the T_c is case temperature

6.5 Full Brick Heat Sinks:

Heat sinks assembly [refer to Datasheet-Thermal](#)



CFB600 Series

Application Note V22 March 2026

6.6 Efficiency VS. Load

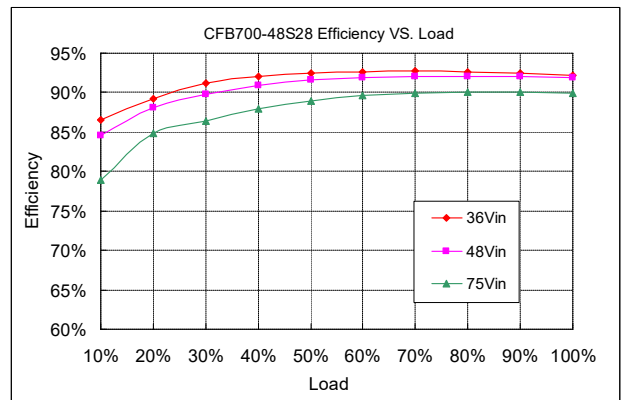
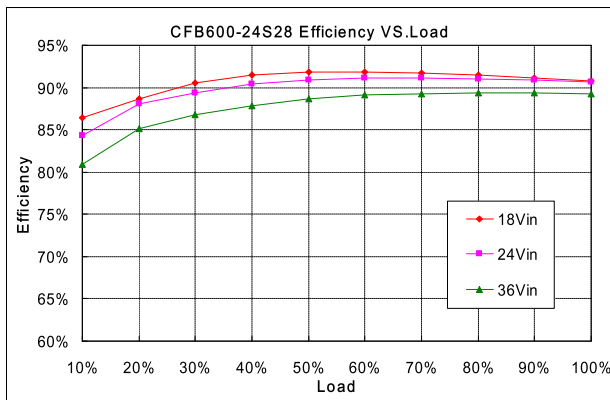
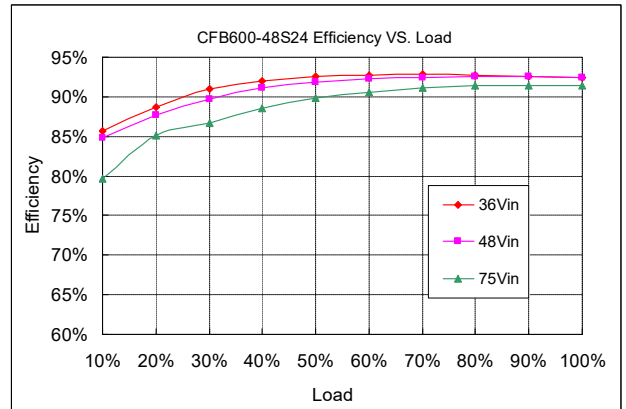
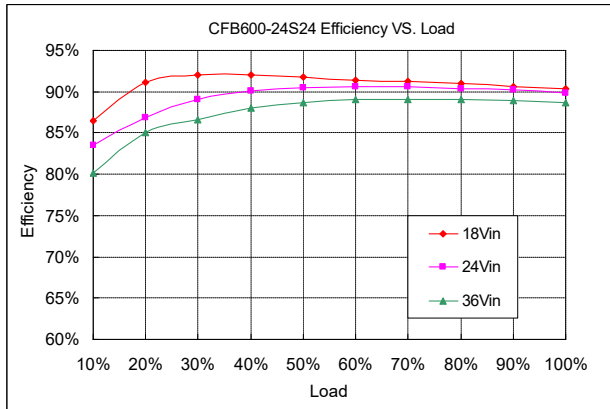
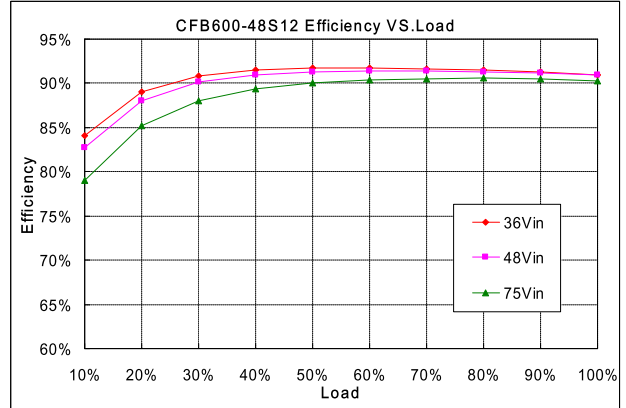
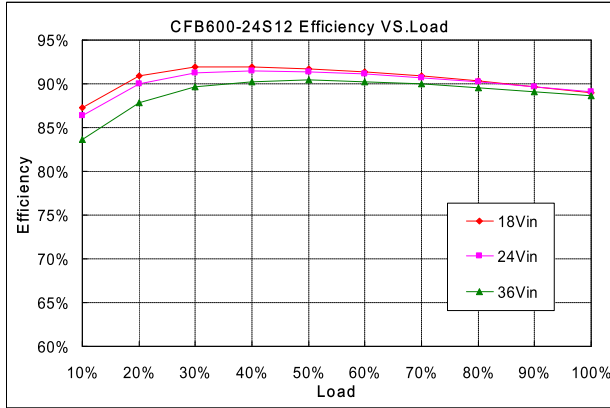



CFB600 Series

Application Note V22 March 2026

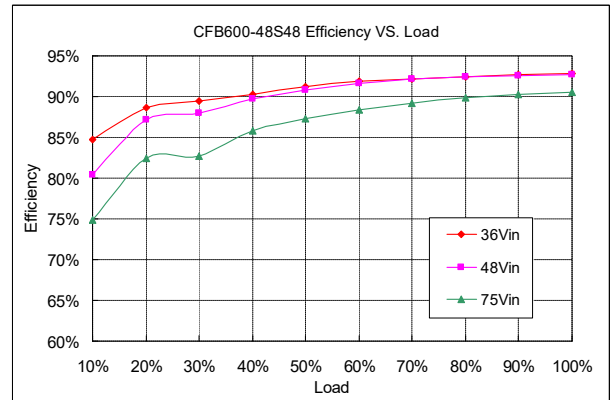
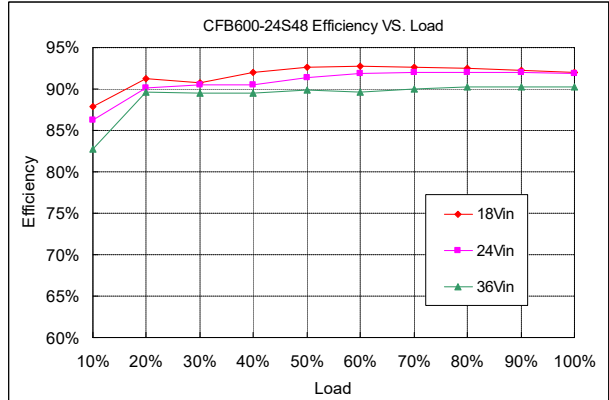
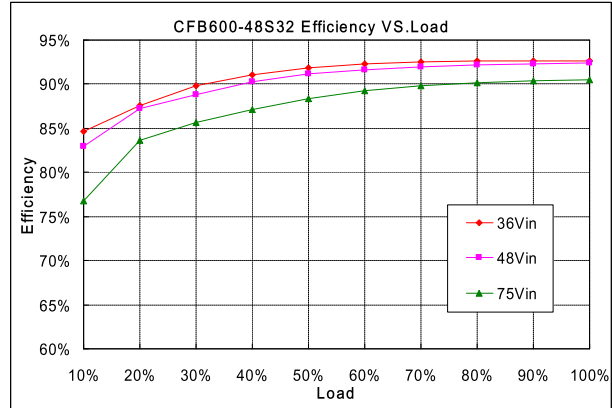
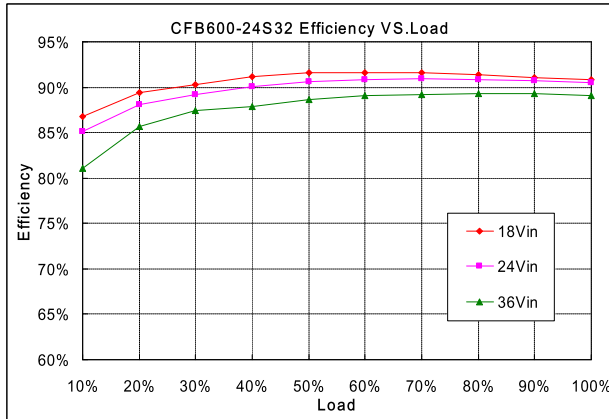



CFB600 Series

Application Note V22 March 2026

6.7 Test Set-Up

The basic test set-up to measure parameters such as efficiency and load regulation is shown below. When testing the modules under any transient conditions please ensure that the transient response of the source is sufficient to power the equipment under test. we can calculate:

- Efficiency
- Load regulation and line regulation

The value of efficiency is defined as:

$$\eta = \frac{V_o \times I_o}{V_{in} \times I_{in}} \times 100\%$$

Where:

- V_o is output voltage,
- I_o is output current,
- V_{in} is input voltage,
- I_{in} is input current

The value of load regulation is defined as:

$$Load.reg = \frac{V_{FL} - V_{NL}}{V_{NL}} \times 100\%$$

Where:

- V_{FL} is the output voltage at full load
- V_{NL} is the output voltage at no load

The value of line regulation is defined as:

$$Line.reg = \frac{V_{HL} - V_{LL}}{V_{LL}} \times 100\%$$

Where:

- V_{HL} is the output voltage of maximum input voltage at full load
- V_{LL} is the output voltage of minimum input voltage at full load

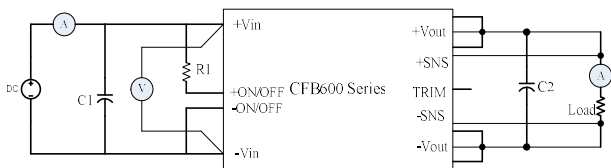

CFB600 Series Test Setup

Recommend C1 and C2 Value

C1: 1000uF/50V for CFB600-24S32, 220uF/100V for other Models

C2: 470uF/100V

For CFB600 series it's necessary to connect the input electrolytic capacitor C1 with low ESR to prevent the effective of input line inductance to the DC/DC converter. For stable operation, connect a low impedance electrolytic capacitor C2 in the output terminals. When operated at lower temperature than -20°C, increasing the C2 capacitance with three or four times more than the recommended value.

6.8 Output Voltage Adjustment

The Trim input permits the user to adjust the output voltage up or down according to the trim range specification (60% to 110% of nominal output). This is accomplished by connecting an external resistor between the +V_{out} and +Sense pin for trim up and between the TRIM and -Sense pin for trim down, see Figure

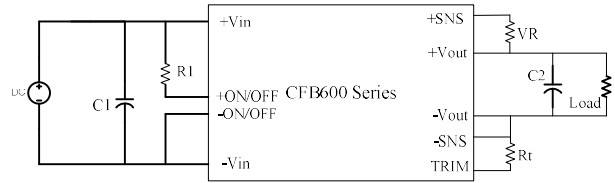

Output voltage trim circuit configuration

The Trim pin should be left open if trimming is not being used. The output voltage can be determined by the following equations:

$$Vf = \frac{1.24 \times \left(\frac{Rt \times 33}{Rt + 33} \right)}{7.68 + \frac{Rt \times 33}{Rt + 33}}$$

$$Vout = (Vo + VR) \times Vf$$

Unit: KΩ

V_o : Nominal Output Voltage

Recommend $Rt=6.8K\Omega$

The output voltage can also be adjustment by using external DC voltage

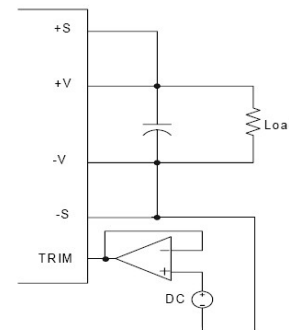

$$\text{Output Voltage} = \text{TRIM Terminal Voltage} \times \text{Nominal Output Voltage}$$



CFB600 Series

Application Note V22 March 2026

6.9 Output Remote Sensing

The CFB600 series converter has the capability to remotely sense both lines of its output. This feature moves the effective output voltage regulation point from the output of the unit to the point of connection of the remote sense pins. This feature automatically adjusts the real output voltage of the CFB600 series in order to compensate for voltage drops in distribution and maintain a regulated voltage at the point of load. The remote-sense voltage range is:

$$\frac{[(+V_{out}) - (-V_{out})] - [(+Sense) - (-Sense)]}{V_{o_nominal}} \leq 10\%$$

If the remote sense feature is not to be used, the sense pins should be connected locally. The +Sense pin should be connected to the +V_{out} pin at the module and the -Sense pin should be connected to the -V_{out} pin at the module.

This is shown in the schematic below.

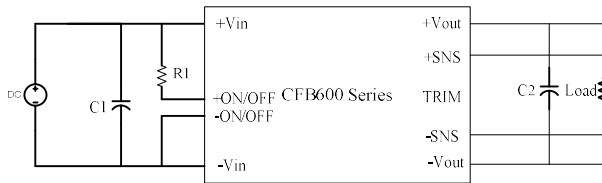

Note:

Although the output voltage can be increased by both the remote sense and by the trim, the maximum increase for the output voltage is not the sum of both. The maximum increase is the larger of either the remote sense or the trim. The amount of power delivered by the module is defined as the voltage at the output terminals multiplied by the output current. When using remote sense and trim, the output voltage of the module can be increased and consequently increase the power output of the module if output current remains unchanged. Care should be taken to ensure that the maximum output power of the module remains at or below the maximum rated power (Maximum rated power = V_{o,set} × I_{o,max}.)

6.10 Output Ripple and Noise

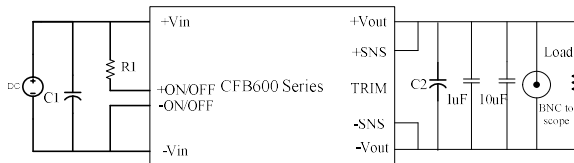

Output ripple and noise is measured with 10uF aluminum and 1.0uF ceramic capacitors for 48V, 1.0uF ceramic and 10uF solid tantalum capacitors for other modules across the output.

6.11 Output Capacitance

The CFB600 series converters provide unconditional stability with or without external capacitors. For good transient response, low ESR output capacitors should be located close to the point of load. PCB design emphasizes low resistance and inductance tracks in consideration of high current applications. Output capacitors with their associated ESR values have an impact on loop stability and bandwidth. The minimum output capacitance is 470uF which need three or four times capacitance when operating below -20°C and the absolute maximum value of CFB600 series output capacitance to see technical specifications.

6.12 Parallel Operation

The CFB600 series are also designed for parallel operation. When paralleled, the load current can be equally shared between the modules by connecting the PC pins together.

There are two different parallel operations for CFB600 series, one is parallel operation when load can't be supplied by only one power unit; the other is the N+1 redundant operation which is high reliable for load of N units by using N+1 units.

(a) parallel operation

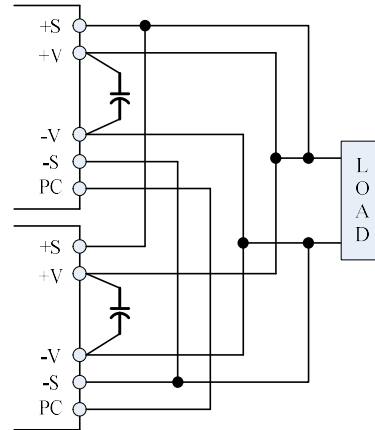



CFB600 Series

Application Note V22 March 2026

(b) Parallel operation with programmed and adjustable output

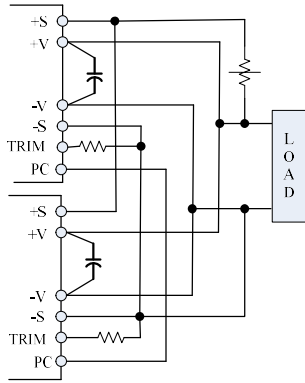

(c) N+1 redundant connection

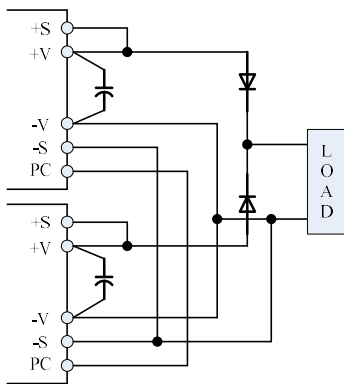

(d) N+1 redundant connection with programmed output and adjustable output voltage

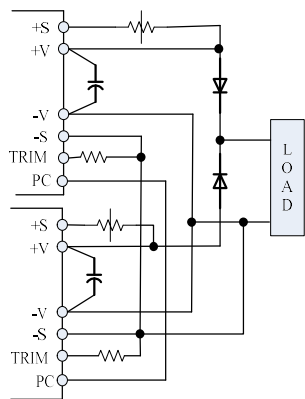

6.13 IOG Signal

Normal and abnormal operation of the converter can be monitored by using the I.O.G signal. Output of this signal monitor is located at the secondary side and is open collector output, you can use the signal by the internal aux power supply or the the external DC supply as the following figures. the ground reference is the -Sense.

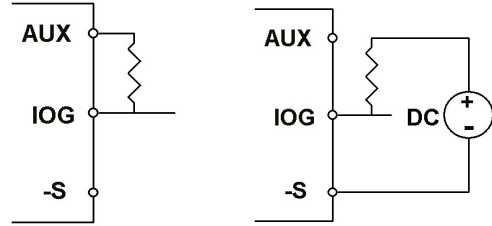

By internal AUX

By external DC supply

This signal is **low** when the converter is normally operating and **high** when the converter is disabled or when the converter is abnormally operating.

6.14 Auxiliary Power for Output Signal

The auxiliary power supply output is within 7-13V with maximum current of 20 mA. Ground reference is the -sense Pin.

6.15 On/Off Control

The converter's **on/off** can be controlled from the input side or the output side.

Output voltage turns on when current is made to through **on/off** terminals which can be reached by opening or closing the switches. The maximum current through the **on/off** pin is 10mA, setting the resistor value to avoid the maximum current through the **on/off** pins.

(A) Controlling the **on/off** terminal from the input side, recommend R1 value is 30K (0.5W) for 48V_{in} and 15K (0.25W) for 24V_{in}.

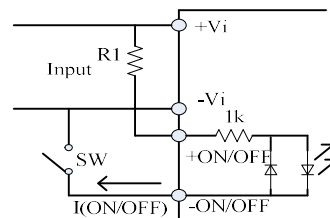

(B) Controlling the **on/off** terminal from the output side, Recommend R2 value is 5.1K (0.1W).

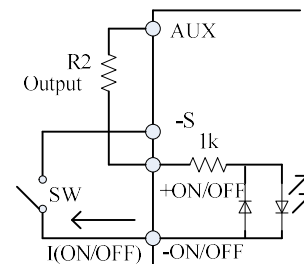



CFB600 Series

Application Note V22 March 2026

7. Safety & EMC

7.1 Input Fusing and Safety Considerations

The CFB600 series converters have no internal fuse. In order to achieve maximum safety and system protection, always use an input line fuse. We recommended a 60A time delay fuse for 24V_{in} models, and 30A for 48V_{in} models. It is recommended that the circuit have a transient voltage suppressor diode (TVS) across the input terminal to protect the unit against surge or spike voltage and input reverse voltage (as shown).

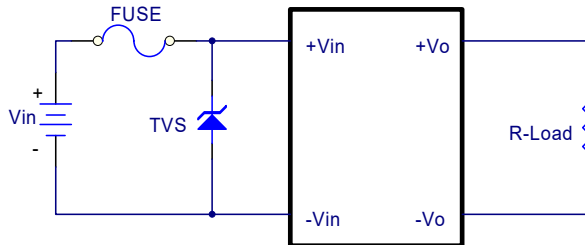

7.2 EMC Considerations

Suggested Circuits for Conducted EMI Class A

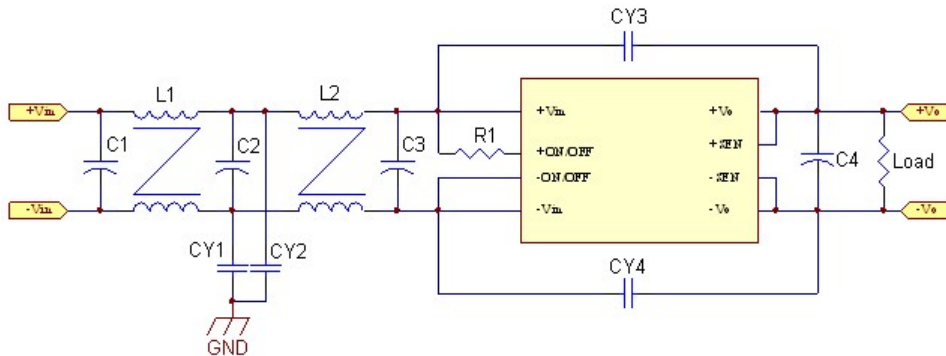

(1) EMI and conducted noise meet EN55032 Class A specifications:

Model No.	C1	C2	C3	CY1/CY2	CY3/CY4	C4	L1	L2	R1
CFB600-24S12	1000uF/50V	2.2uF/100V	1000uF/50V	0.1uF	NC	470uF/100V+10uF/50V	Short	1mH	15K
CFB600-24S24	1000uF/50V	2.2uF/100V	1000uF/50V	0.1uF	NC	470uF/100V+10uF/50V	Short	1mH	15K
CFB600-24S28	1000uF/50V	2.2uF/100V	1000uF/50V	0.1uF	NC	470uF/100V+10uF/50V	Short	1mH	15K
CFB600-24S32	1000uF/50V	2.2uF/100V	1000uF/50V	0.1uF	NC	470uF/100V+10uF/50V	Short	1mH	15K
CFB600-24S48	1000uF/50V	2.2uF/100V	1000uF/50V	0.1uF	NC	470uF/100V+10uF/50V	Short	1mH	15K
CFB600-48S12	NC	470uF/100V	470uF/100V	10000pF	10000pF*2	470uF/100V	Short	2mH	30K
CFB600-48S24	NC	470uF/100V	470uF/100V	10000pF	10000pF*2	470uF/100V	Short	2mH	30K
CFB700-48S28	NC	470uF/100V	470uF/100V	10000pF	10000pF*2	470uF/100V	Short	2mH	30K
CFB600-48S32	NC	470uF/100V	470uF/100V	10000pF	10000pF*2	470uF/100V	Short	2mH	30K
CFB600-48S48	NC	470uF/100V	470uF/100V	10000pF	10000pF*2	470uF/100V	Short	2mH	30K

Note:

1000uF/50V is NIPPON CHEMI-CON KY series aluminum capacitors, 470uF/100V is Nichicon PS(M) series aluminum capacitors, Y1, CY2, CY3 & CY4 is Y1 capacitors, other capacitors is ceramic capacitors 2220 size. Inductor core material is VAC W523, 1mH is 1.2mm*2 6T, 2mH is 1.5mm*1 8T.



CFB600 Series

Application Note V22 March 2026

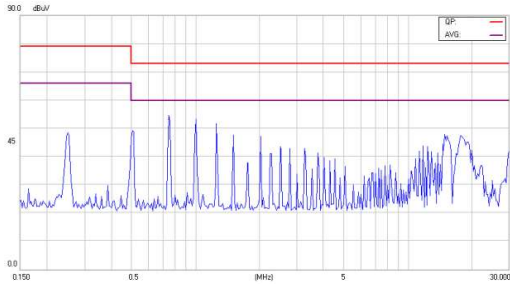

Conducted Class A of CFB600-24S12

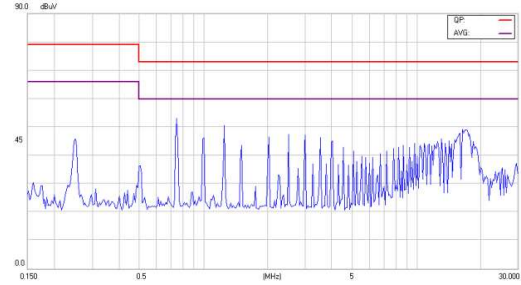

Conducted Class A of CFB600-24S24

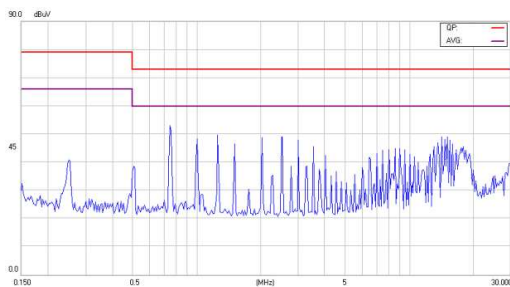

Conducted Class A of CFB600-24S28

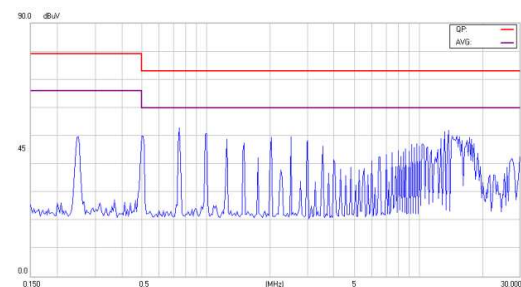

Conducted Class A of CFB600-24S32

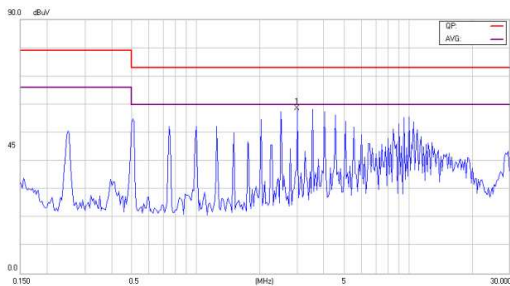

Conducted Class A of CFB600-24S48

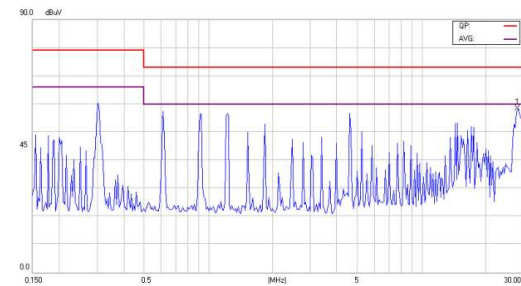

Conducted Class A of CFB600-48S12

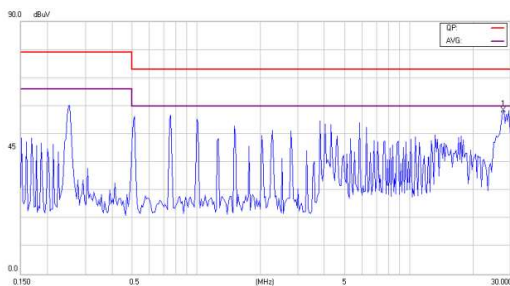

Conducted Class A of CFB600-48S24

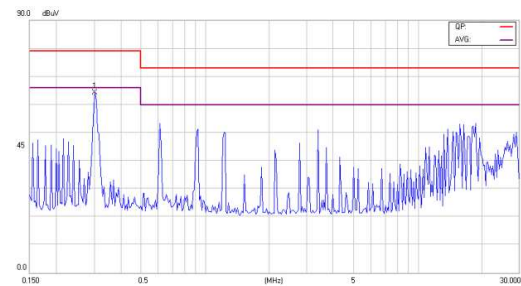

Conducted Class A of CFB700-48S28

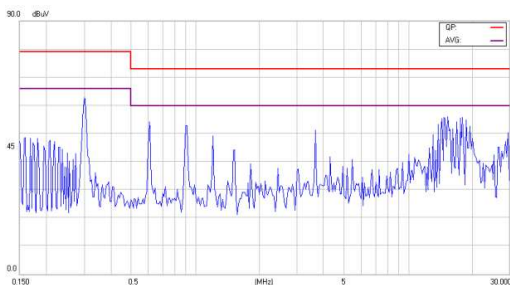

Conducted Class A of CFB600-48S32

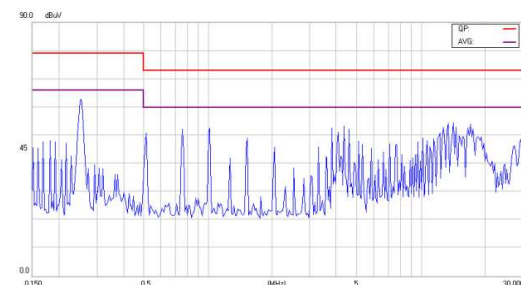

Conducted Class A of CFB600-48S48



CFB600 Series Application Note V22 March 2026

8. Part Number

Format: CFB600 – II X OO L

Parameter	Series	Nominal Input Voltage	Number of Outputs	Output Voltage	Remote On/Off Logic
Symbol	CFB600	II	X	00	L
Value	CFB600 CFB700	24: 24 Volts 48: 48 Volts	S: Single	12: 12 Volts 24: 24 Volts 28: 28 Volts 32: 32 Volts 48: 48 Volts	None: Negative P: Positive

Headquarters:

14F, No.306, Sec.4, Hsin Yi Rd.
Taipei, Taiwan
Tel: 886-2-27086210
Fax: 886-2-27029852
E-mail: sales@cincon.com
Web Site: <https://www.cincon.com>

CINCON ELECTRONICS CO., LTD.

Factory:

No. 8-1, Fu Kung Rd.
Fu Hsing Industrial Park
Fu Hsing Hsiang,
Chang Hua Hsien, Taiwan
Tel: 886-4-7690261
Fax: 886-4-7698031

Cincon North America:

1655 Mesa Verde Ave. Ste 180
Ventura, CA 93003
Tel: 805-639-3350
Fax: 805-639-4101
E-mail: info@cincon.com