



CFM06S Series

Application Note V15 October 2020

AC-DC Switching Power Module CFM06S Series APPLICATION NOTE



Approved By:

Department	Approved By	Checked By	Written By
Research and Development Department	Enoch	Yang	Su Shih Hang
		Ovid	
Quality Assurance Department	Ryan	Benny	



CFM06S Series

Application Note V15 October 2020

Content

1. INTRODUCTION	3
2. CFM06S SERIES FEATURES	3
3. ELECTRICAL BLOCK DIAGRAM	3
4. TECHNICAL SPECIFICATIONS	4
5. MAIN FEATURES AND FUNCTIONS	7
5.1 <i>Operating Temperature Range</i>	7
5.2 <i>Output Protection</i>	7
6. EMC & SAFETY	7
7. APPLICATIONS	7
7.1 <i>Power De-Rating Curve</i>	7
7.2 <i>Test Set-Up</i>	7
7.3 <i>Output Ripple and Noise Measurement</i>	7
7.4 <i>Installation Instruction</i>	8
8. CFM06S SERIES MECHANICAL OUTLINE DIAGRAMS	9
8.1 <i>Mechanical Outline Diagrams</i>	9
8.2 <i>Packing Information</i>	9
9. PART NUMBER	11



CFM06S Series

Application Note V15 October 2020

1. Introduction

This application note describes the features and functions of Cincon's CFM06S series of open frame, switching AC-DC power module. These are highly efficient, reliable, compact, high power density, single output AC/DC power modules. The module is fully protected against short circuit and over-voltage conditions. Cincon's world class automated manufacturing methods, together with an extensive testing and qualification program, ensure that the CFM06S series power module is extremely reliable.

2. CFM06S Series Features

- Universal Input 90~264VAC
- High Efficiency Up to 83%
- Approved EN55032 Class B and CISPR/FCC Class B
- Approved IEC/EN/UL 62368-1
- Meets IEC/EN60335-1
- Continuous Short Circuit Protection
- Over Voltage Protection
- No Load Input Power < 75mW
- Constant Current (Optional)
- Class II

3. Electrical Block Diagram

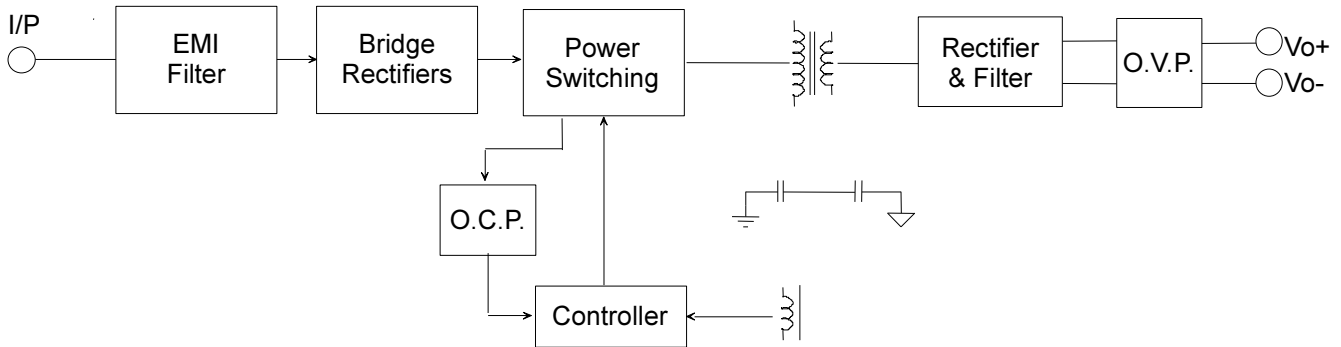



CFM06S Series

Application Note V15 October 2020

4. Technical Specifications

(All specifications are typical at nominal input, full load at 25°C unless otherwise noted.)

ABSOLUTE MAXIMUM RATINGS						
PARAMETER	NOTES and CONDITIONS	Device	Min.	Typical	Max.	Units
Input Voltage		All	90		264	Vac
			120		370	Vdc
Operating Temperature	See derating curve	All	-40		80	°C
Storage Temperature		All	-40		85	°C
Input/Output Isolation Voltage	1 minute	All	3000			Vac
Altitude		All			5000	m

INPUT CHARACTERISTICS

PARAMETER	NOTES and CONDITIONS	Device	Min.	Typical	Max.	Units
Operating Voltage Range		All	100		240	Vac
Input Frequency Range		All	47		63	Hz
Maximum Input Current	100% Load, Vin=100Vac	All			0.25	A
Leakage Current		All			0.25	mA
Inrush Current	Vin=240Vac, cold start at 25°C.	All			90	A

OUTPUT CHARACTERISTICS

PARAMETER	NOTES and CONDITIONS	Device	Min.	Typical	Max.	Units
Output Voltage Set Point	Vin=Nominal Vin, Io=Io.max, Tc=25°C.	CFM06S033	3.10	3.3	3.49	Vdc
		CFM06S050	4.75	5	5.25	
		CFM06S090	8.55	9	9.45	
		CFM06S120	11.64	12	12.36	
		CFM06S150	14.55	15	15.45	
		CFM06S240	23.28	24	24.72	
Operating Output Current Range		CFM06S033			1.5	A
		CFM06S050			1.2	
		CFM06S090			0.67	
		CFM06S120			0.5	
		CFM06S150			0.4	
		CFM06S240			0.25	
Holdup Time	Vin=115Vac	All		12		ms
Output Voltage Regulation						
Load Regulation	10% load to full load	CFM06S033			±6.0	%
		CFM06S050			±5.0	
		CFM06S090			±5.0	
		CFM06S120			±3.0	
		CFM06S150			±3.0	
		CFM06S240			±3.0	
Line Regulation	Vin=high line to low line	All			±1.0	%



CFM06S Series

Application Note V15 October 2020

PARAMETER	NOTES and CONDITIONS	Device	Min.	Typical	Max.	Units
Over Voltage Protection		CFM06S033 CFM06S050 CFM06S090 CFM06S120 CFM06S150 CFM06S240			7.14 7.14 12.1 15.8 19.5 31.5	Vdc
Output Ripple and Noise	1. Add a 0.1uF ceramic capacitor and a 10uF aluminum electrolytic capacitor to output. 2. Oscilloscope is 20MHz band width. 3. Ambient temperature=25°C	CFM06S033 CFM06S050 CFM06S090 CFM06S120 CFM06S150 CFM06S240			100 100 100 120 150 240	mVp-p
Load Capacitance	1. Ambient temperature=25°C 2. Input voltage is 115VAC and 230VAC 3. Output is max. load	CFM06S033 CFM06S050 CFM06S090 CFM06S120 CFM06S150 CFM06S240			1500 1200 670 500 400 250	uF
Efficiency	Efficiency measured at 100% load and input voltage is 230Vac.	CFM06S033 CFM06S050 CFM06S090 CFM06S120 CFM06S150 CFM06S240		75 78 81 81 81 83		%

ISOLATION CHARACTERISTICS

PARAMETER	NOTES and CONDITIONS	Device	Min.	Typical	Max.	Units
Input to Output	1 minute	All			3000	Vac
Isolation Resistance		All	100			MΩ

FEATURE CHARACTERISTICS

PARAMETER	NOTES and CONDITIONS	Device	Min.	Typical	Max.	Units
Switching Frequency		All	30		70	KHz



CFM06S Series

Application Note V15 October 2020

GENERAL SPECIFICATIONS

PARAMETER	NOTES and CONDITIONS	Device	Min.	Typical	Max.	Units
MTBF	Io=100%; Ta=25°C per MIL-HDBK-217F	CFM06S033 CFM06S050 CFM06S090 CFM06S120 CFM06S150 CFM06S240		610 820 1070 920 1100 1120		K hours
Humidity	Nom-condensing	All			93	% RH
Shock	Mests MIL-STD-810F Table 516.5, TABLE 516.5-1 10ms, each axis 3 times(+X · Y · Z axis)	All		75		g
Vibration	Mests MIL-STD-810F Table 514.5C-VIII, 15~2000Hz, X · Y · Z axis, 1 hr(each axis),. toal 3 hrs.	All		4		g
Weight		CFM06SXXX CFM06SXXX-E CFM06SXXX-T		11.0 30.0 12.0		g
Safety	Class II, IEC62368-1, UL62368-1, EN62368-1, IEC60950-1					
EMC Emission	EN55032, EN61000-3-2, EN6100-3-3, EN61000-6-3, Class B. EN61000-6-4. 47 CFR FCC Part 15 Subpart B (Class B)					
Conducted Disturbance	EN55032 2015, EN6100-6-3 2007+A1: 2011+AC: 2012, Class B. EN61000-6-4. 47 CFR FCC Part 15 Subpart B (Class B)					
Radiated Disturbance	EN55032 2015, EN6100-6-3 2007+A1: 2011+AC: 2012, Class B. EN61000-6-4 47 CFR FCC Part 15 Subpart B (Class B)					
Harmonic Current Emissions	EN6100-3-2:2014					
Voltage Fluctuations & Flicker	EN6100-3-3:2013					
EMC Immunity	EN55024 2010+A1:2015, EN61204-3 2000, EN61000-6-1:2007, EN61000-6-2:2005					
Electrostatic Discharge (ESD)	IEC 61000-4-2:2008					Criteria A
Radio-Frequency, Continuous Radiated Disturbance	IEC 61000-4-3:2010					Criteria A
Electrical Fast Transient (EFT)	IEC 61000-4-4:2012					Criteria A
Surge	IEC 61000-4-5:2014					Criteria A
Conducted Disturbances, Induced by RF Fields	IEC 61000-4-6:2013					Criteria A
Power Frequency Magnetic Field	IEC 61000-4-8:2009					Criteria B
Voltage Dips	IEC 61000-4-11:2004					Criteria B
Voltage Interruptions	IEC 61000-4-11:2004					Criteria B



CFM06S Series

Application Note V15 October 2020

5. Main Features and Functions

5.1 Operating Temperature Range

The highly efficient design of Cincon's CFM06S series power modules has resulted in their ability to operate within ambient temperature environments from -40°C to 80°C. Due consideration must be given to the de-rating curves when ascertaining the maximum power that can be drawn from the module. The maximum power which can be drawn is influenced by a number of factors, such as:

- Input voltage range
- Permissible Output load (per derating curve)

5.2 Output Protection

The power modules provide full continuous short-circuit protection. The unit will auto recover once the short circuit is removed. To provide protection in a fault condition, the unit is equipped with internal over-current protection. The unit will operate normally once the fault condition is removed.

6. EMC & Safety

- Emission and Immunity
EN55032 Class B, EN55024, EN61204-3, EN61000-3-2, EN6100-3-3, EN61000-6-1, EN61000-6-2, EN61000-6-3, EN61000-6-4
47 CFR FCC Part 15 Subpart B (Class B)
- Safety
Class II, IEC62368-1, UL62368-1, EN62368-1, IEC60950-1

7. Applications

7.1 Power De-Rating Curve

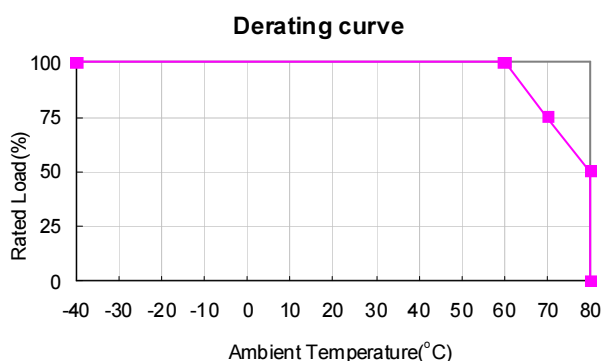

7.2 Test Set-Up

The basic test set-up to measure parameters such as efficiency and load regulation is shown in Figure 1. When testing the Cincon's CFM06S series under any transient conditions, please ensure that the transient response of the source is sufficient to power the

equipment under test. We can calculate the

- Efficiency
- Load regulation and line regulation

The value of efficiency is defined as:

Where:

V_o is output voltage

I_o is output current

P_{in} is input power

The value of load regulation is defined as:

Where:

V_{FL} is the output voltage at full load

V_{NL} is the output voltage at 10% load

The value of line regulation is defined as:

$$Line\ reg. = \frac{V_{HL} - V_{LL}}{V_{LL}} \times 100\%$$

Where:

V_{HL} is the output voltage of maximum input voltage at full load.

V_{LL} is the output voltage of minimum input voltage at full load.

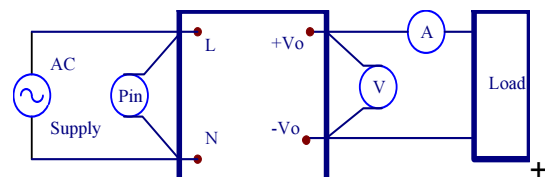

Figure 1. CFM06S Series Test Setup

7.3 Output Ripple and Noise Measurement

The test set-up for noise and ripple measurements is shown in Figure 2 Measured method:

Add a 0.1 uF ceramic capacitor and a 10 uF electrolytic capacitor to output at 20 MHz Band Width.

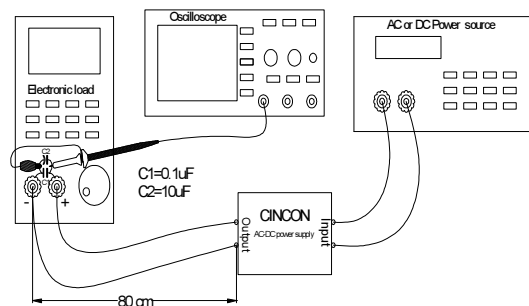

Figure 2. Output Voltage Ripple and Noise Measurement Set-Up



CFM06S Series

Application Note V15 October 2020

7.4 Installation Instruction

The CFM06SXXX-T has two 3.2mm diameter mounting holes. Please use the mounting holes as follows: Insert the spacer (6mm diameter max.) of 8mm height or more to mount the unit. The vibration specification applies when the unit is mounted on 8mm spacers. Please allow 4mm side clearance from the components and all side of the PCB. Allow 5mm clearance above the highest parts on the PCB. Be especially careful to allow 8mm between the solder side of the PCB and the mounting surface. If the clearances are not sufficient, the specifications for isolation and withstand will not be valid.

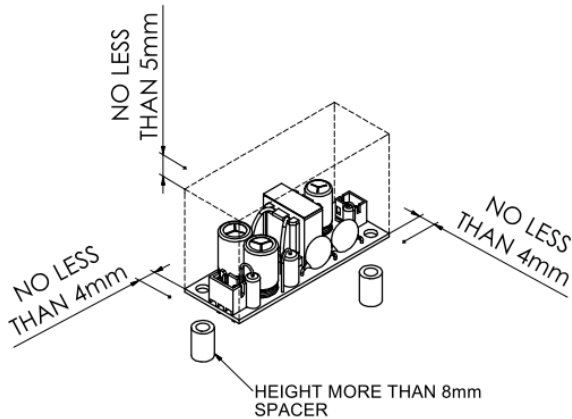

The CFM06SXXX and CFM06SXXX-E mounting holes are 1.5mm. Please allow 4mm side clearance from the components and all side of the PCB and CASE. Allow 5mm clearance above the highest parts on the PCB and CASE.

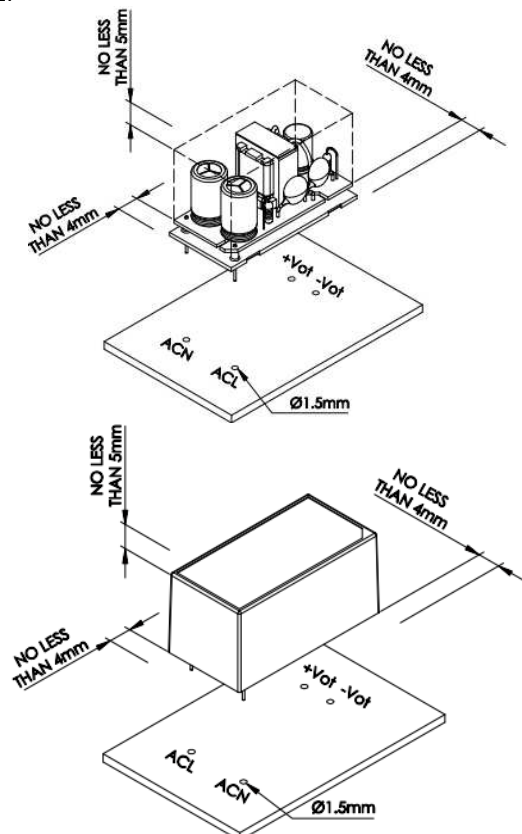



CFM06S Series

Application Note V15 October 2020

8. CFM06S Series Mechanical Outline Diagrams

8.1. Mechanical Outline Diagrams

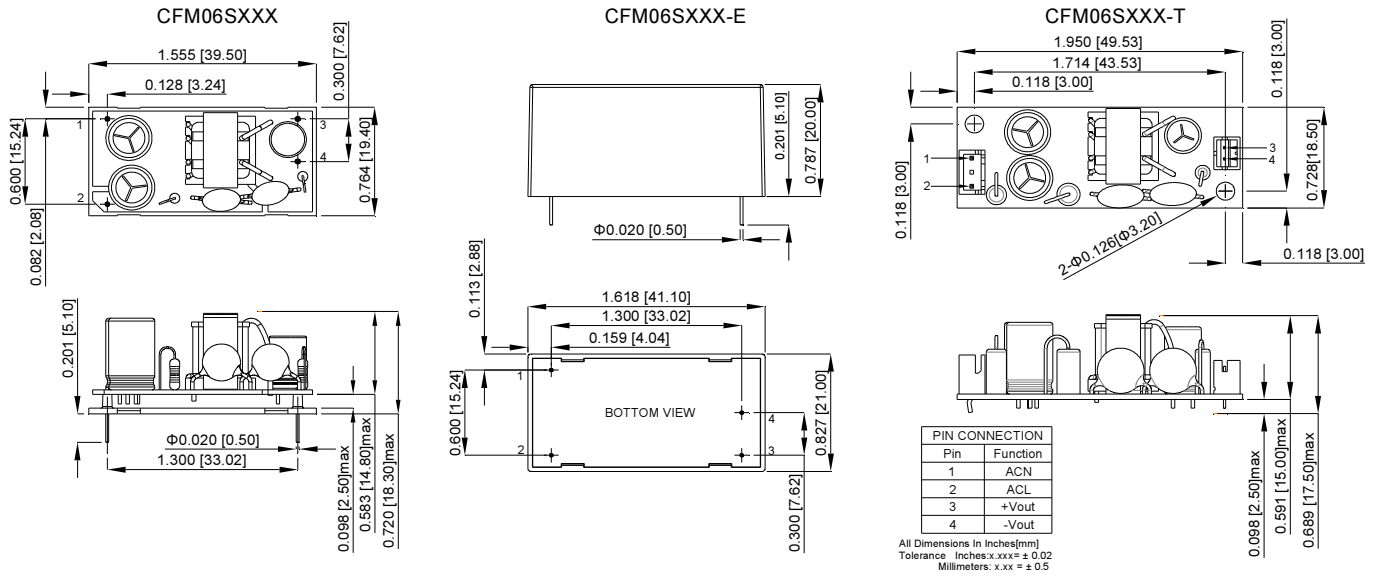
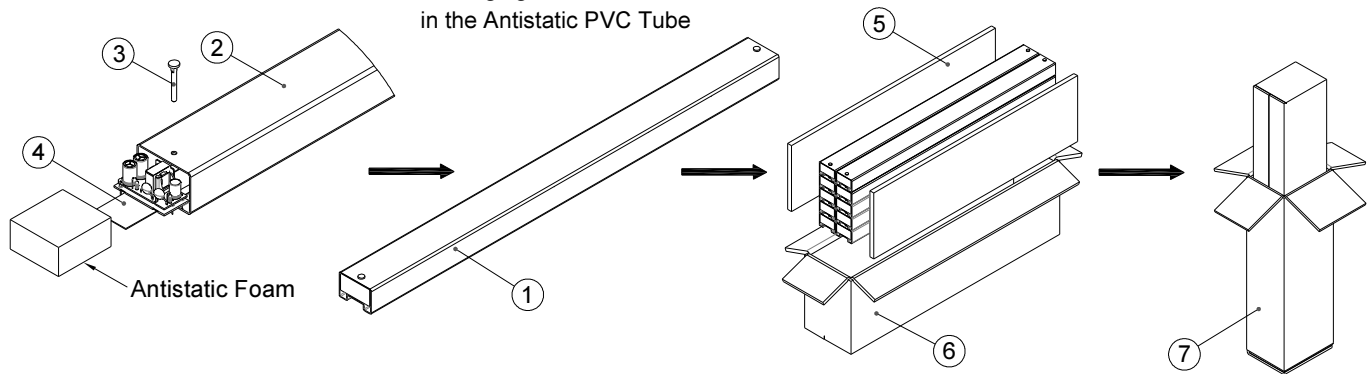

Figure 3. CFM06S series Mechanical Outline Diagram

8.2. Packing Information

The packing information for CFM06SXXX series is showing as follows:

Packaging 22PCS Products
in the Antistatic PVC Tube



ITEM	PART NO.	NAME	OUTSIDE DIM	PCS
1	-	CFM06SXXX Product	39.5*19.4*18.3mm	220
2	G64910945	Antistatic PVC Tube	42.2*28.5*535mm	10
3	-	Tube Nail	-	20
4	G64U15132	Spacer	500*25*0.6mm	10
5	G64301154	Antistatic Foam	535*150*10mm	2
6	G64203214	No.14 Inner Cardboard Box	548.4*121.2*166.7mm	1
7	G64112338	No.14 Cardboard Box	590.9*148.5*193.9mm	1

Each Box Packaging 220PCS Products
Gross weight Ref. 4.5Kg

CFM06SXXX 220pcs a box, including the total weight of package material about 4.5Kg



CFM06S Series

Application Note V15 October 2020

The packing information for CFM06SXXX-E series is showing as follows:

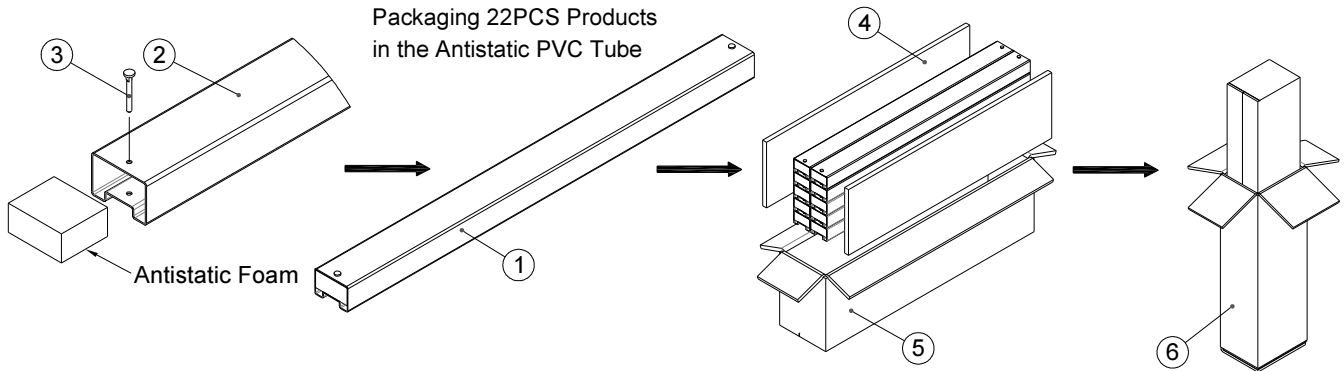

ITEM	PART NO.	NAME	OUTSIDE DIM	PCS
1	-	CFM06SXXX-E Product	41.1*21*20mm	220
2	G64910942	Antistatic PVC Tube	43.6*29.1*535mm	10
3	-	Tube Nail	-	20
4	G64301154	Antistatic Foam	535*150*10mm	2
5	G64203214	No.14 Inner Cardboard Box	548.4*121.2*166.7mm	1
6	G64112338	No.14 Cardboard Box	590.9*148.5*193.9mm	1

Each Box Packaging 220PCS Products
Gross weight Ref. 8.5Kg

CFM06SXXX-E 220pcs a box, including the total weight of package material about 8.5Kg

The packing information for CFM06SXXX-T series is showing as follows:

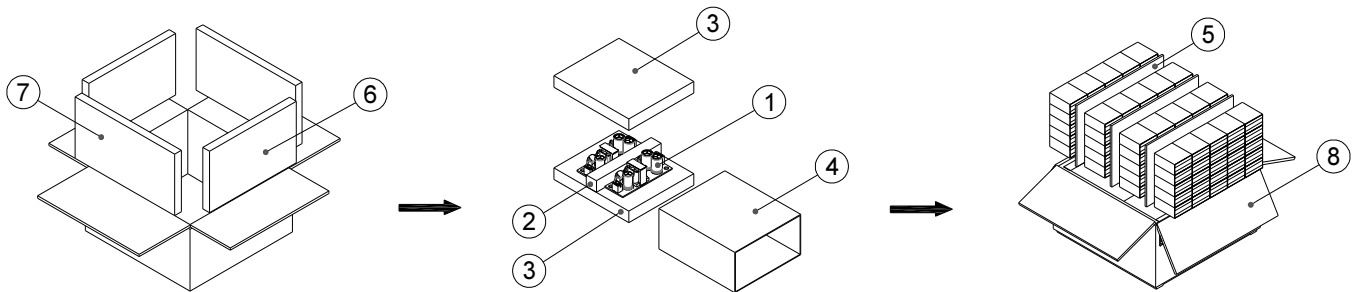

ITEM	PART NO.	NAME	OUTSIDE DIM	PCS
1	-	CFM06SXXX-T Product	49.53x18x17.5mm	200
2	G64301178	Antistatic Foam	65x10x10 mm	100
3	G64308311	Antistatic Foam	75x65x10 mm	200
4	G64304162	Inner Box	76x66x35 mm	100
5	G64U10075	Partition	326x200x6 mm	3
6	G64301114	Antistatic Foam	326x200x25 mm	2
7	G64301113	Antistatic Foam	373x200x25 mm	2
8	G64114346	No.148 Cardboard Box	393x385x220 mm	1

Each Box Packaging 200PCS Products
Gross weight Ref. 3.5Kg

CFM06SXXX-T 200pcs a box, including the total weight of package material about 3.5Kg



CFM06S Series

Application Note V15 October 2020

9. Part Number

CFM XX S XXX-X

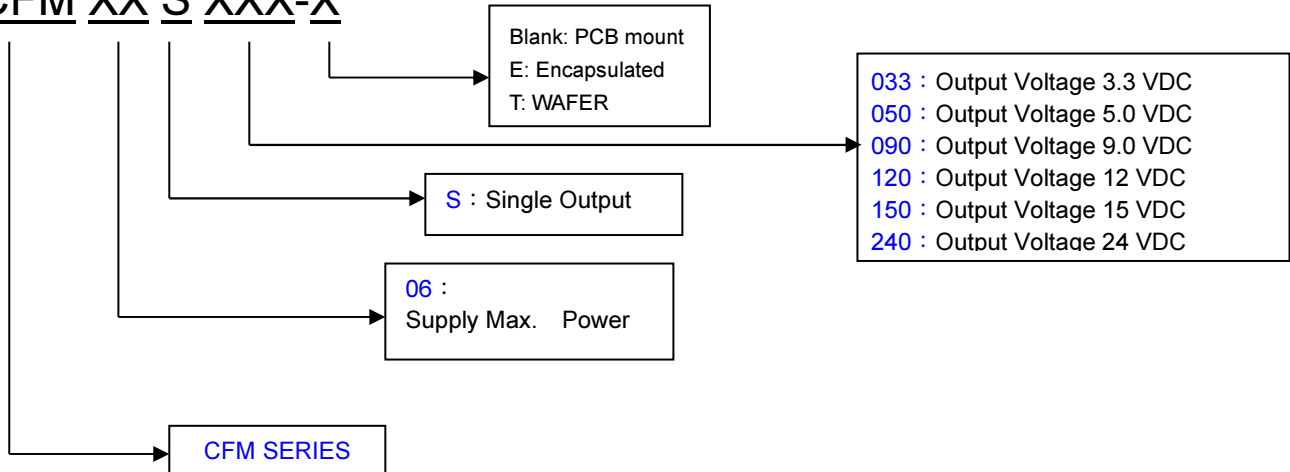

CINCON ELECTRONICS CO., LTD.

Headquarters:

14F, No.306, Sec.4, Hsin Yi Rd.
Taipei, Taiwan
Tel: 886-2-27086210
Fax: 886-2-27029852
E-mail: support@cincon.com.tw
Web Site: <http://www.cincon.com>

Factory:

No. 8-1, Fu Kung Rd.
Fu Hsing Industrial Park
Fu Hsing Hsiang,
Chang Hua Hsien, Taiwan
Tel: 886-4-7690261
Fax: 886-4-7698031

Cincon North America:

1655 Mesa Verde Ave. Ste 180
Ventura, CA 93003
Tel: 805-639-3350
Fax: 805-639-4101
E-mail: info@cincon.com