

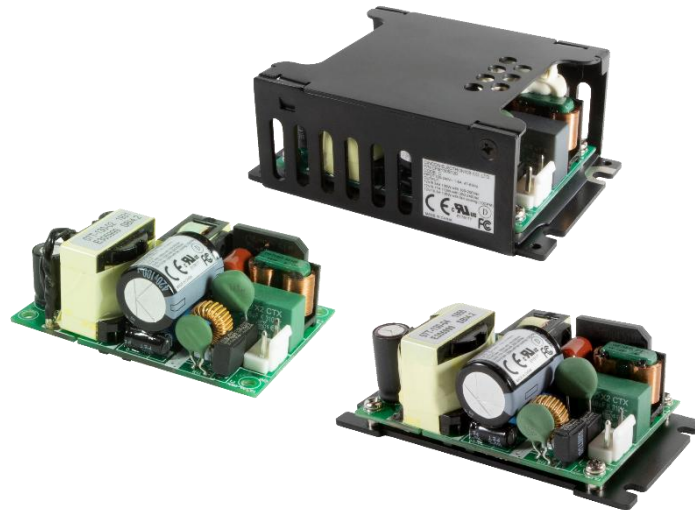

CFM130S Series

Application Note V13 December

130W AC-DC Power Supply with PFC CFM130S Series APPLICATION NOTE



Approved By:

Department	Approved By	Checked By	Written By
Research and Development Department	Ovid	Calvin	Kaimi
Design Quality Department	Benny	JoJo	



CFM130S Series

Application Note V13 December

Content

1. INTRODUCTION	3
2. ELECTRICAL BLOCK DIAGRAM	3
3. MAIN FEATURES AND FUNCTIONS	4
3.1 <i>Operating Temperature Range</i>	4
3.2 <i>Output Protection (Over Current Protection)</i>	4
4. APPLICATIONS	4
4.1 <i>Test Set-Up</i>	4
4.2 <i>Output Ripple and Noise Measurement</i>	4
4.3 <i>Installation Instruction</i>	5
4.4 <i>EMI Test</i>	6
4.5 <i>Mating Connectors</i>	6
5. PACKING INFORMATION	7



CFM130S Series

Application Note V13 December

1. Introduction

This application note describes the features and functions of Cincon's CFM130S series of open frame, switching AC-DC power module. These are highly efficient, reliable, compact, high power density, single output AC/DC power modules. The module is fully protected against short circuit and over-voltage conditions. Cincon's world class automated manufacturing methods, together with an extensive testing and qualification program, ensure that the CFM130S series power module is extremely reliable.

2. Electrical Block Diagram

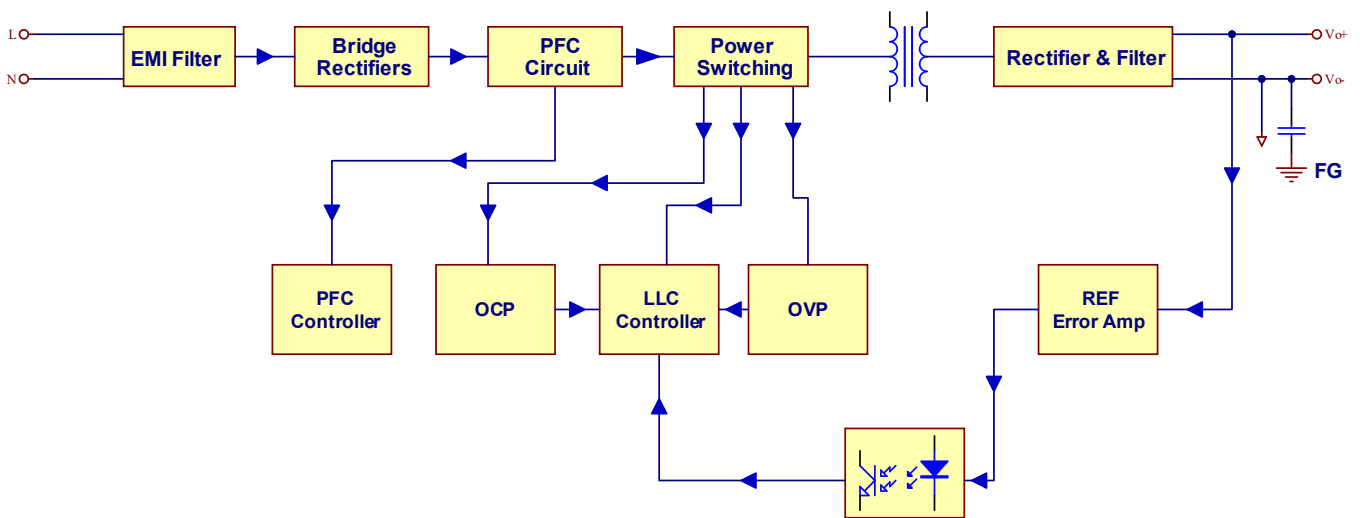



CFM130S Series

Application Note V13 December

3. Main Features and Functions

3.1 Operating Temperature Range

The highly efficient design of Cincon's CFM130S series power modules has resulted in their ability to operate within ambient temperature environments from -30°C to 70°C. Due consideration must be given to the de-rating curves when ascertaining the maximum power that can be drawn from the module. The maximum power which can be drawn is influenced by a number of factors, such as:

- Input voltage range
- Permissible output load (per derating curve)
- Effective heat sinks

3.2 Output Protection (Over Current Protection)

The power modules provide full continuous short-circuit protection. The unit will auto recover once the short circuit is removed. To provide protection in a fault condition, the unit is equipped with internal over-current protection range, please refer to the specification sheet. The unit will operate normally once the fault condition is removed.

4. Applications

4.1 Test Set-Up

The basic test set-up to measure parameters such as efficiency and load regulation is shown in Figure 1. When testing the Cincon's CFM130S series under any transient conditions, please ensure that the transient response of the source is sufficient to power the equipment under test. We can calculate the

- Efficiency
- Load regulation and line regulation

The value of efficiency is defined as:

$$\eta = \frac{V_o \times I_o}{P_{in}} \times 100\%$$

Where:

- V_o is output voltage
- I_o is output current
- P_{in} is input power

The value of load regulation is defined as:

$$Load\ reg. = \frac{V_{FL} - V_{NL}}{V_{NL}} \times 100\%$$

Where:

- V_{FL} is the output voltage at full load
- V_{NL} is the output voltage at 10% load

The value of line regulation is defined as:

$$Line\ reg. = \frac{V_{HL} - V_{LL}}{V_{LL}} \times 100\%$$

Where:

- V_{HL} is the output voltage of maximum input voltage at full load
- V_{LL} is the output voltage of minimum input voltage at full load

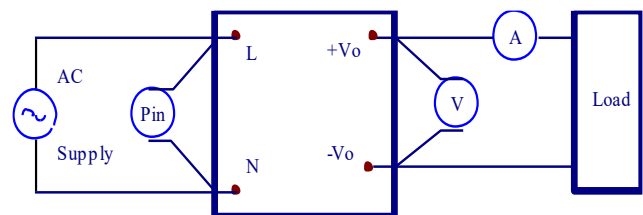

Figure 1. CFM130S Series Test Setup

4.2 Output Ripple and Noise Measurement

The test set-up for noise and ripple measurements is shown in Figure 2. Measured method:

Add a $C2=0.1\mu F$ ceramic capacitor and a $C1=10\mu F$ electrolytic capacitor to output at 20 MHz Band Width.

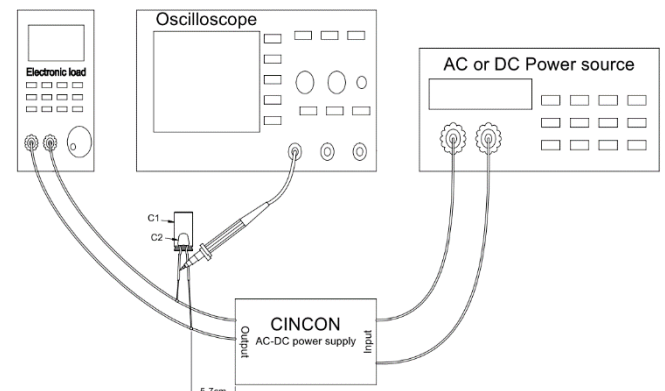

Figure 2. Output Voltage Ripple and Noise Measurement Set-Up



CFM130S Series

Application Note V13 December

4.3 Installation Instruction

The CFM130S series has four 3.2mm diameter mounting holes. There are three type installations for CFM130S. Please use the mounting holes as follows: Insert the spacer (5.5mm diameter max.) of 5mm height or more to mount the unit.

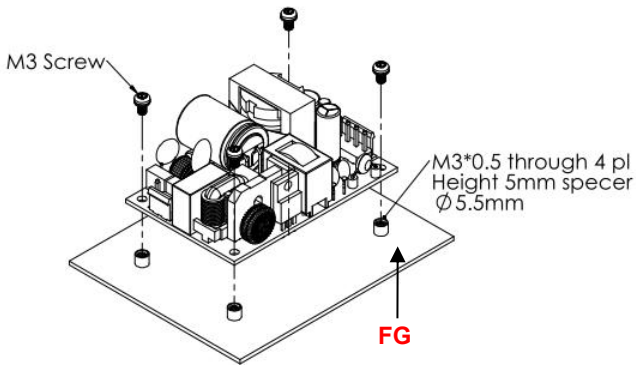

CFM130SXXX Installation Diagram

Note:
M3 screw head and washer diameter shall not exceed 5.5mm.

The CFM130S series provide the baseplate cooling for customer to increasing heat dissipation. Please refer to the following figure for installation.

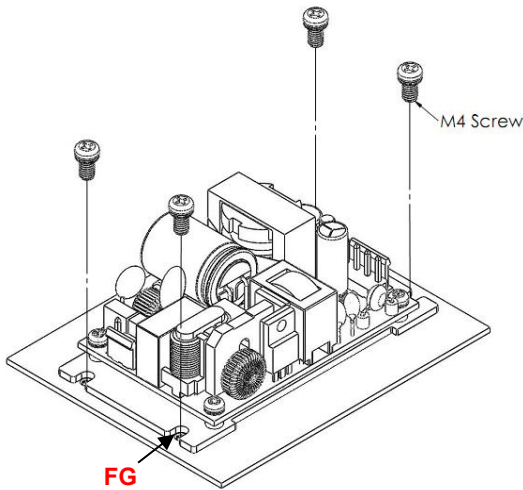

CFM130SXXX-B installation diagram

Note:
M4 screw head and washer diameter shall not exceed 5.5mm.

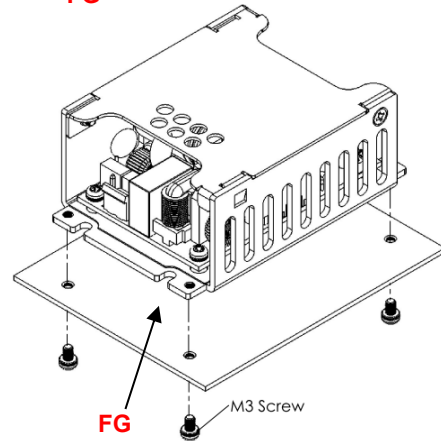
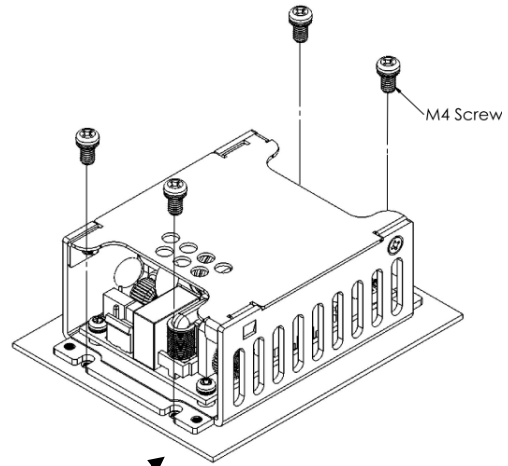

CFM130SXXX-C installation diagram

Note:
M3&M4 screw head and washer diameter shall not exceed 5.5mm

Please allow 4mm side clearance from the components and all side of the PCB. Allow 5mm clearance above the highest parts on the PCB. Be especially careful to allow 5mm between the solder side of the PCB and the mounting surface. If the clearances are not sufficient the specifications for isolation and withstand will not be valid.

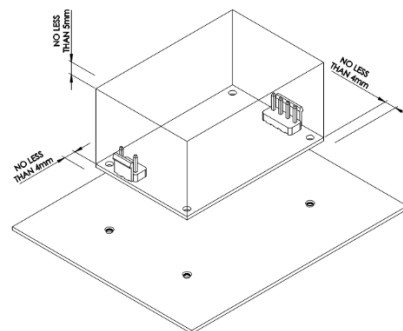

FG should be connected to the earth (ground) terminal of the apparatus. If not the conducted noise and output noise will increase.



CFM130S Series

Application Note V13 December

4.4 EMI Test

The CFM130S series Conductive EMI meets EN55032 FCC Part 15 Class B when test condition is Class I & Class II.

Radiation meet EN55032, FCC Part 15 Class B when test condition is Class I.

Radiation meet EN55032, FCC Part 15 Class A when test condition is Class II.

4.5 Mating Connectors

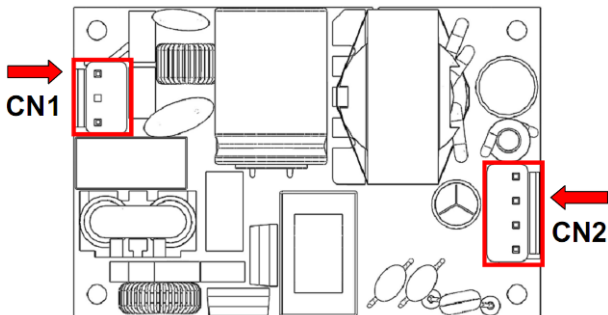

AC Input (CN1) DC Output (CN2)	Wafer: TAIWAN KING PIN TERMINAL PVHI series or equivalent. Housing: JST VHR series or equivalent.
-----------------------------------	--



CFM130S Series

Application Note V13 December

5. Packing Information

The packing information for CFM130SXXX series is showing as follows:

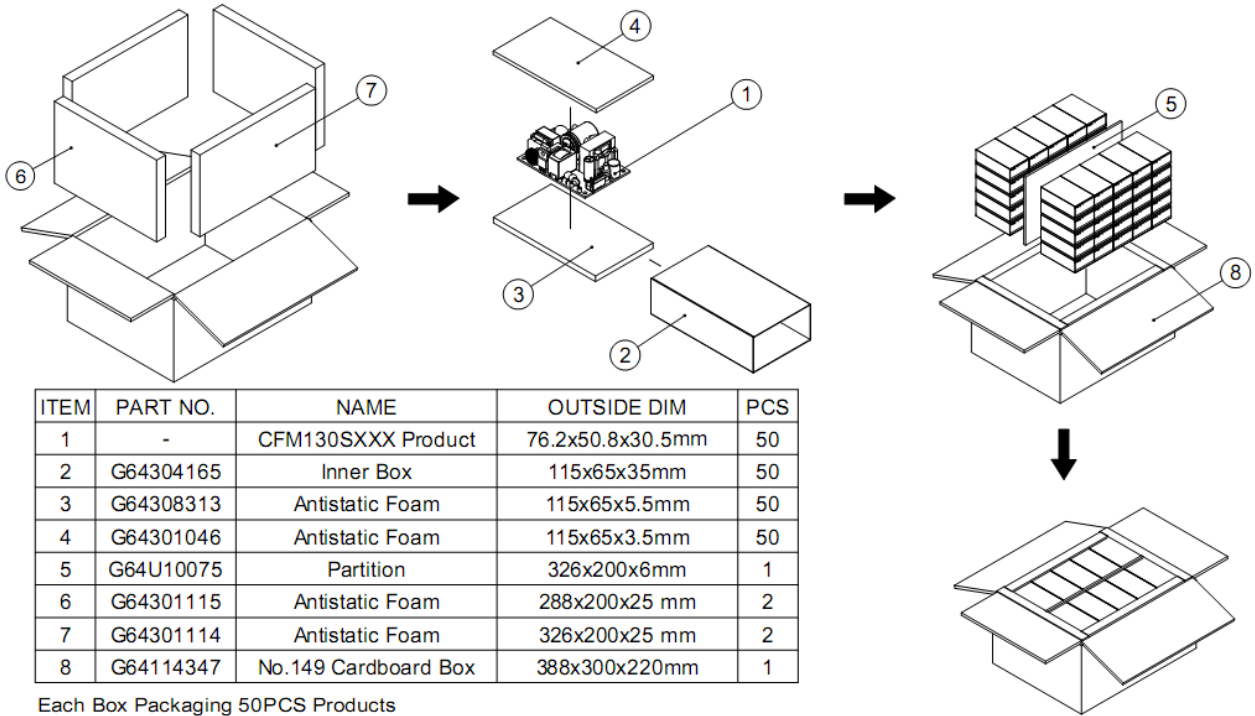

ITEM	PART NO.	NAME	OUTSIDE DIM	PCS
1	-	CFM130SXXX Product	76.2x50.8x30.5mm	50
2	G64304165	Inner Box	115x65x35mm	50
3	G64308313	Antistatic Foam	115x65x5.5mm	50
4	G64301046	Antistatic Foam	115x65x3.5mm	50
5	G64U10075	Partition	326x200x6mm	1
6	G64301115	Antistatic Foam	288x200x25 mm	2
7	G64301114	Antistatic Foam	326x200x25 mm	2
8	G64114347	No.149 Cardboard Box	388x300x220mm	1

Each Box Packaging 50PCS Products
 Net weight Ref. 6.8 Kg
 Gross Weight Ref. 8.3Kg

The packing information for CFM130SXXX-B series is showing as follows:

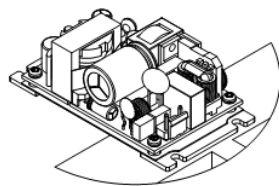

Detail Enlargement A

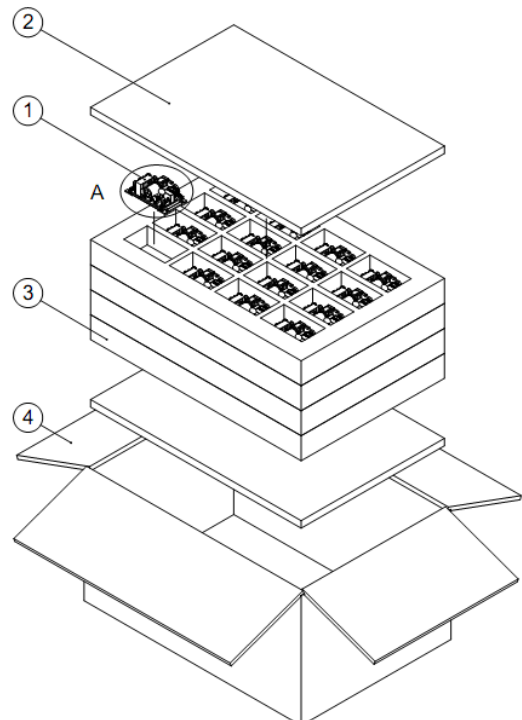

ITEM	PART NO.	NAME	OUTSIDE DIM(mm)	PCS
1	-	CFM130SXXX-B Product	91.4x50.8x33.06mm	64
2	G64301208	Antistatic Foam	485x330x15mm	2
3	G64301209	Antistatic Foam	485x330x50mm	4
4	G64100099	No.49 Cardboard Box	500x345x260mm	1

Each Box Packaging 64 PCS Products
 Net weight Ref. 10.88 Kg
 Gross weight Ref. 12.38 Kg



CFM130S Series

Application Note V13 December

The packing information for CFM130SXXX-C series is showing as follows:

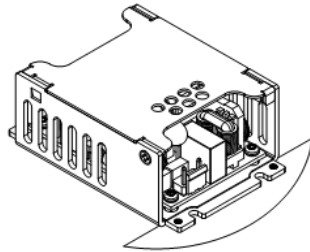

Detail Enlargement A

ITEM	PART NO.	NAME	OUTSIDE DIM(mm)	PCS
1	-	CFM130SXXX-C Product	91.4x64x34.5mm	48
3	G64301210	Antistatic Foam	485x330x50mm	4
2	G64301208	Antistatic Foam	485x330x15mm	2
4	G64100099	No.49 Cardboard Box	500x345x260mm	1

Each Box Packaging 48 PCS Products

Net weight Ref. 10.464 Kg

Gross weight Ref. 11.964 Kg

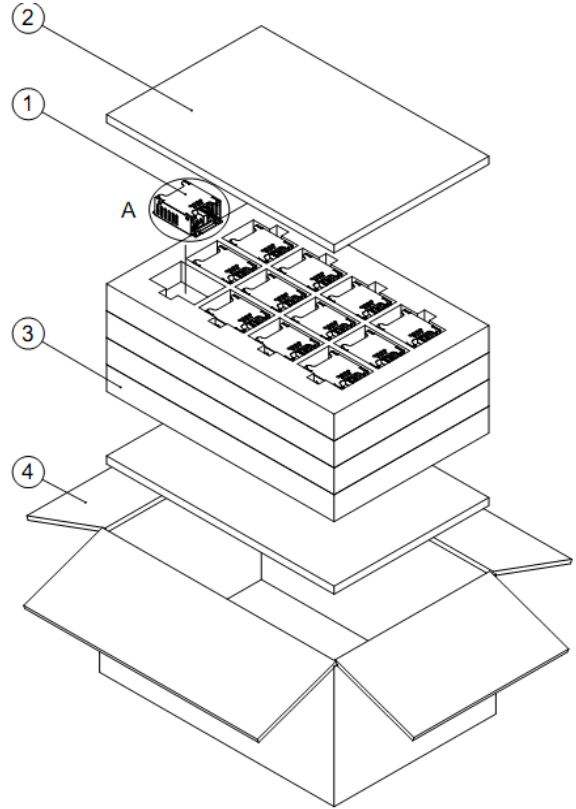

Headquarters:

14F, No.306, Sec.4, Hsin Yi Rd.
 Taipei, Taiwan
 Tel: 886-2-27086210
 Fax: 886-2-27029852
 E-mail: sales@cincon.com.tw
 Web Site: <https://www.cincon.com>

CINCON ELECTRONICS CO., LTD.

Factory:

No. 8-1, Fu Kung Rd.
 Fu Hsing Industrial Park
 Fu Hsing Hsiang,
 Chang Hua Hsien, Taiwan
 Tel: 886-4-7690261
 Fax: 886-4-7698031

Cincon North America:

1655 Mesa Verde Ave. Ste 180
 Ventura, CA 93003
 Tel: 805-639-3350
 Fax: 805-639-4101
 E-mail: info@cincon.com