



# CFM21M Series

Application Note V13 September 2020

## AC-DC Switching Power Module CFM21M Series APPLICATION NOTE



**Approved By:**

Department	Approved By	Checked By	Written By
Research and Development Department	Enoch	Tim/ Felix	Joyce
		Ovid	
Quality Assurance Department	Ryan	Benny	



# CFM21M Series

## Application Note V13 September 2020

---

### Content

<b>1. INTRODUCTION</b>	<b>3</b>
<b>2. CFM21M SERIES FEATURES</b>	<b>3</b>
<b>3. ELECTRICAL BLOCK DIAGRAM</b>	<b>3</b>
<b>4. TECHNICAL SPECIFICATIONS</b>	<b>4</b>
<b>5. MAIN FEATURES AND FUNCTIONS</b>	<b>6</b>
5.1 <i>Operating Temperature Range</i>	6
5.2 <i>Output Protection</i>	6
<b>6. EMC &amp; SAFETY</b>	<b>6</b>
<b>7. APPLICATIONS</b>	<b>6</b>
7.1 <i>Power De-Rating Curve</i>	6
7.2 <i>Test Set-Up</i>	6
7.3 <i>Output Ripple and Noise Measurement</i>	7
7.4 <i>Installation Instruction</i>	7
<b>8. PART NUMBER</b>	<b>8</b>
<b>9. CFM21M SERIES MECHANICAL OUTLINE DIAGRAMS</b>	<b>9</b>
9.1 <i>Mechanical Outline Diagrams</i>	9
9.2 <i>Packing Information</i>	10



# CFM21M Series

## Application Note V13 September 2020

### 1. Introduction

This application note describes the features and functions of Cincon's CFM21M series of switching AC-DC power module. These are highly efficient, reliable, compact, high power density, single output AC/DC power modules. The module is fully protected against short circuit and over-voltage conditions. Cincon's world class automated manufacturing methods, together with an extensive testing and qualification program, ensure that the CFM21M series power module is extremely reliable.

### 2. CFM21M Series Features

- Universal Input Range 90~264VAC
- Class II
- Miniature Size and Low Profile 0.8"
- Industry-Standard Pin Out
- Efficiency to 85%
- Option for On-Board, Connector, Screw Terminal or Encapsulated type
- Continuous Short Circuit Protection
- Over Voltage Protection
- No Load Input Power < 0.1W
- Leakage Current < 100uA
- ANSI/AAMI ES 60601-1/IEC60601-1/EN60601-1 Ed.3.1 Medical Safety Approved
- 2 MOPP
- Peak Load 130%
- Meet UL62368/IEC62368/EN62368
- Meet UL60335-1/IEC60335-1/EN60335-1

### 3. Electrical Block Diagram

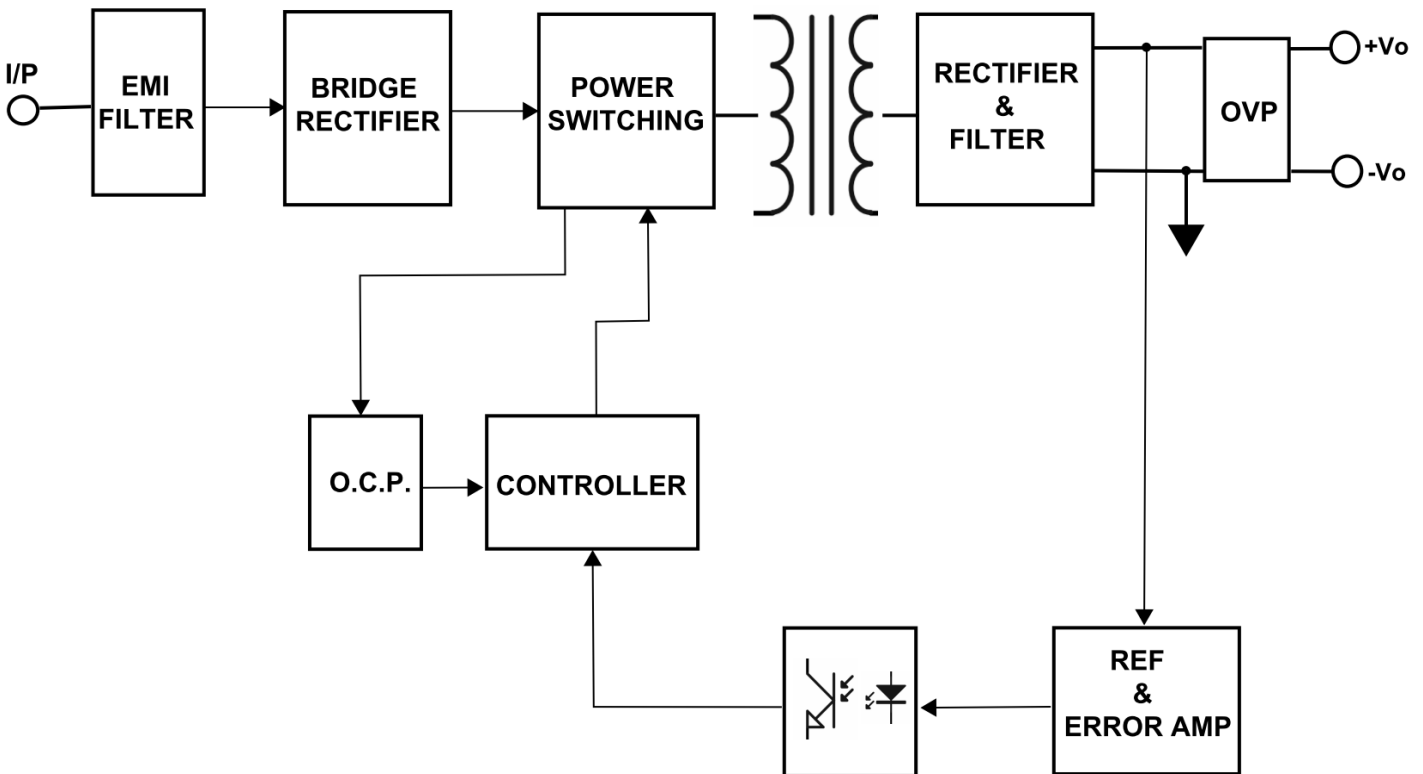



# CFM21M Series

## Application Note V13 September 2020

### 4. Technical Specifications

(All specifications are typical at nominal input, full load at 25°C unless otherwise noted.)

ABSOLUTE MAXIMUM RATINGS						
PARAMETER	NOTES and CONDITIONS	Device	Min.	Typical	Max.	Units
Input Voltage (Continuous)		All	90		264	Vac
Operating Temperature	See derating curve	All	-25		+60	°C
Storage Temperature		All	-40		+85	°C
Input/Output Isolation Voltage	1 minute	All	5656			Vdc
INPUT CHARACTERISTICS						
PARAMETER	NOTES and CONDITIONS	Device	Min.	Typical	Max.	Units
Operating Voltage Range		All	100		240	Vac
Input Frequency Range		All	47		63	Hz
Maximum Input Current	100% Load, Vin=100Vac	All			0.5	A
Leakage Current		All		70	100	uA
Inrush Current	Vin=240Vac, cold start at 25°C.	All			40	A
OUTPUT CHARACTERISTICS						
PARAMETER	NOTES and CONDITIONS	Device	Min.	Typical	Max.	Units
Output Voltage Set Point	Vin=Nominal Vin, Io=Io.max, Tc=25°C.	CFM21M050	4.95	5.0	5.05	Vdc
		CFM21M090	8.91	9.0	9.09	
		CFM21M120	11.88	12.0	12.12	
		CFM21M150	14.85	15.0	15.15	
		CFM21M240	23.76	24.0	24.24	
Operating Output Current Range		CFM21M050			4	A
		CFM21M090			2.3	
		CFM21M120			1.7	
		CFM21M150			1.4	
		CFM21M240			0.9	
Holdup Time	Vin=115Vac	All		10		ms
Output Voltage Regulation						
Load Regulation	10% load to full load	All			±1.0	%
Line Regulation	Vin=high line to low line	All			±0.5	%
Over Voltage Protection	uses a TVS component to clamp output voltage	CFM21M050		6.8		Vdc
		CFM21M090		11		
		CFM21M120		15		
		CFM21M150		18		
		CFM21M240		30		
Output Ripple and Noise	1. Add a 0.1uF ceramic capacitor and a 10uF aluminum electrolytic capacitor to output. 2. oscilloscope is 20MHz band width. 3. Ambient temperature=25°C	CFM21M050			50	mVp-p
		CFM21M090			90	
		CFM21M120			100	
		CFM21M150			100	
		CFM21M240			100	



# CFM21M Series

## Application Note V13 September 2020

PARAMETER	NOTES and CONDITIONS	Device	Min.	Typical	Max.	Units
Load Capacitance	1. Ambient temperature=25°C 2. Input voltage is 115VAC and 230VAC 3. Output is max. load	CFM21M050			4000	uF
		CFM21M090			2300	
		CFM21M120			1700	
		CFM21M150			1400	
		CFM21M240			900	
Efficiency	Output is Rated Load Ambient temperature=25°C	CFM21M050		81		%
		CFM21M090		83		
		CFM21M120		85		
		CFM21M150		85		
		CFM21M240		86		

### ISOLATION CHARACTERISTICS

PARAMETER	NOTES and CONDITIONS	Device	Min.	Typical	Max.	Units
Input to Output	1 minute	All	5656			Vdc
Isolation Resistance		All	1000			MΩ

### FEATURE CHARACTERISTICS

PARAMETER	NOTES and CONDITIONS	Device	Min.	Typical	Max.	Units
Switching Frequency		All		65		KHz

### GENERAL SPECIFICATIONS

PARAMETER	NOTES and CONDITIONS	Device	Min.	Typical	Max.	Units
MTBF	Io=100%; Ta=25°C per MIL-HDBK-217F	All		500		K hours
Weight		CFM21MXX		55		g
		CFM21MXX-T		60		
		CFM21MXX-S		60		
		CFM21MXX-E		110		
Safety	Class II, IEC60601-1/ANSI/AAMI ES 60601-1/EN60601-1 Medical.					Ed.3.1
EMC Emission	EN55011 Class B, EN60601-1-2:2015, EN61000-3-2:2014, EN6100-3-3:2013, IEC61000-4-2, IEC61000-4-3, IEC61000-4-4, IEC61000-4-5, IEC61000-4-6, IEC61000-4-8, IEC61000-4-11					Ed.4.0
Conducted disturbance	EN55011, EN61000-6-3:2012, Class B,					
Radiated disturbance	EN55011, EN61000-6-3:2012, Class B,					
Harmonic current emissions	EN61000-3-2:2014					
Voltage fluctuations & flicker	EN61000-3-3:2013					
EMC Immunity	EN55024, EN61204-3:2000, EN61000-6-1:2007,					
Electrostatic discharge (ESD)	IEC 61000-4-2:2008, Air discharge: ±15KV, Contact discharge: ±8KV					
Radio-frequency, Continuous radiated disturbance	IEC 61000-4-3:2010					
Electrical fast transient (EFT)	IEC 61000-4-4:2012, ±0.5kv, ±1kv, ±2kv					
Surge	IEC 61000-4-5:2014, L-N: ±0.5kv, ±1kv,					
Conducted disturbances, induced by RF fields	IEC 61000-4-6:2013					
Power frequency magnetic field	IEC 61000-4-8:2009					
Voltage dips	IEC 61000-4-11:2004, Dip: 30% 10ms, Dip: 60% 100ms, Dip >95% 5000ms					
Voltage interruptions	IEC 61000-4-11:2004, >95% 5000ms					



# CFM21M Series

## Application Note V13 September 2020

### 5. Main Features and Functions

#### 5.1 Operating Temperature Range

The highly efficient design of Cincon's CFM21M series power modules has resulted in their ability to operate within ambient temperature environments from -25°C to 70°C. Due consideration must be given to the de-rating curves when ascertaining the maximum power that can be drawn from the module. The maximum power which can be drawn is influenced by a number of factors, such as:

- Input voltage range
- Permissible Output load (per derating curve)
- Effective heat sinks

#### 5.2 Output Protection

The power modules provide full continuous short-circuit protection. The unit will auto recover once the short circuit is removed. To provide protection in a fault condition, the unit is equipped with internal over-current protection. The unit will operate normally once the fault condition is removed. The power module will go to hiccup mode if the output current is set from 130% to 180% of rated current.

### 6. EMC & Safety

#### ■ Emissions

- EN55011ClassB,
- EN61000-3-2:2014, EN61000-3-3:2013,
- EN60601-1-2 2015/IEC 61000-4-2
- IEC61000-4-3/IEC61000-4-4
- IEC61000-4-5/IEC61000-4-6/IEC61000-4-8
- IEC61000-4-11

#### ■ Safety Approvals

- IEC60601-1 Ed.3.1
- ANSI/AAMI ES 60601-1:2005/A1:2012&C1:2009/(R)2012&2010/(R)2012
- CAN/CSA-C22.2 NO. 60601-1:14
- EN60601-1:2006+A11:2011+A1:2013
- IEC60601-1:2005+A1:2012

### 7. Applications

#### 7.1 Power De-Rating Curve

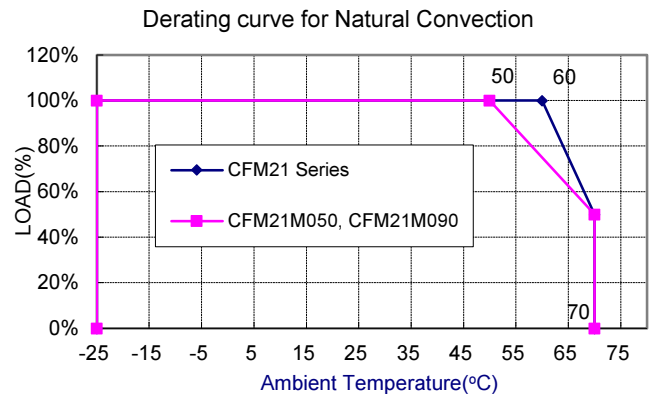

#### 7.2 Test Set-Up

The basic test set-up to measure parameters such as efficiency and load regulation is shown in Figure 1. When testing the Cincon's CFM21M series under any transient conditions, please ensure that the transient response of the source is sufficient to power the equipment under test. We can calculate the

- Efficiency
- Load regulation and line regulation.

The value of efficiency is defined as:

$$\eta = \frac{V_o \times I_o}{P_{in}} \times 100\%$$

Where:

- Vo is output voltage
- Io is output current
- Pin is input power

The value of load regulation is defined as:

$$\text{Load reg.} = \frac{V_{FL} - V_{NL}}{V_{NL}} \times 100\%$$

Where:

- V<sub>FL</sub> is the output voltage at full load
- V<sub>NL</sub> is the output voltage at 10% load



# CFM21M Series

## Application Note V13 September 2020

The value of line regulation is defined as:

$$\text{Line reg.} = \frac{V_{HL} - V_{LL}}{V_{LL}} \times 100\%$$

Where:

$V_{HL}$  is the output voltage of maximum input voltage at full load.

$V_{LL}$  is the output voltage of minimum input voltage at full load.

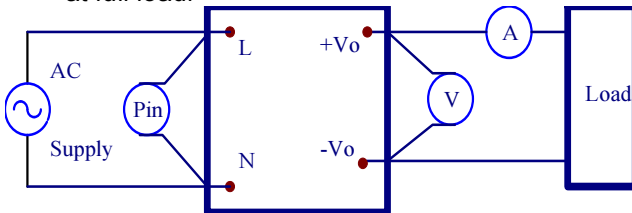

Figure 1. CFM21M Series Test Setup

### 7.3 Output Ripple and Noise Measurement

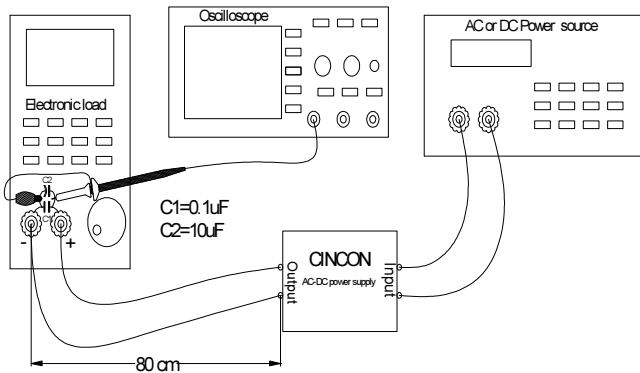
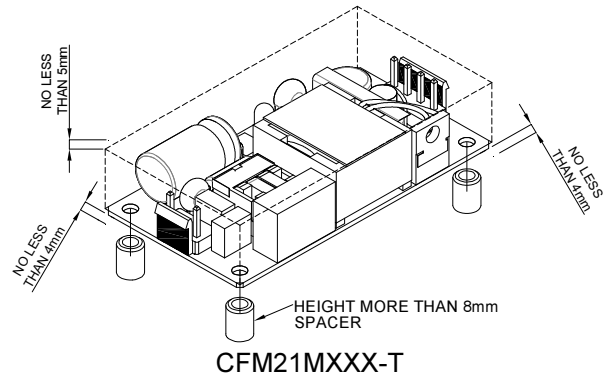

Figure 2. Output Voltage Ripple and Noise Measurement Set-Up

### 7.4 Installation Instruction

The CFM21MXXX-T and CFM21MXXX-S has four 3.5mm diameter mounting holes. Please use M3 screw and M3 washer. Please use the mounting holes as follows: Insert the spacer (6mm diameter max.) of 8mm height or more to mount the unit. The vibration specification applies when the unit is mounted on 8mm spacers. Please allow 4mm side clearance from the components and all side of the PCB. Allow 5mm clearance above the highest parts on the PCB. Be especially careful to allow 8mm between the solder side of the PCB and the mounting surface. If the clearances are not sufficient, the specifications for isolation and withstand will not be valid.



CFM21MXXX-T

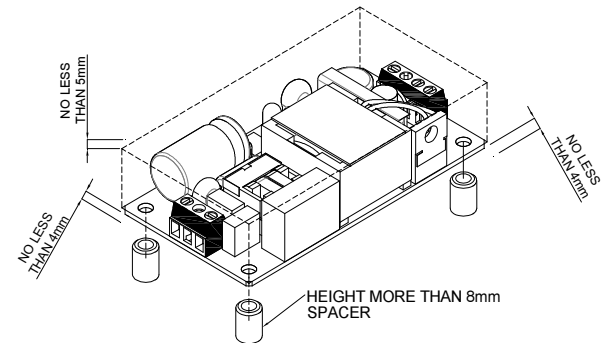

CFM21MXXX-S

The CFM21MXXX and CFM21MXXX-E mounting holes are 1.5mm. Please allow 4mm side clearance from the components and all side of the PCB and CASE. Allow 5mm clearance above the highest parts on the PCB and CASE.

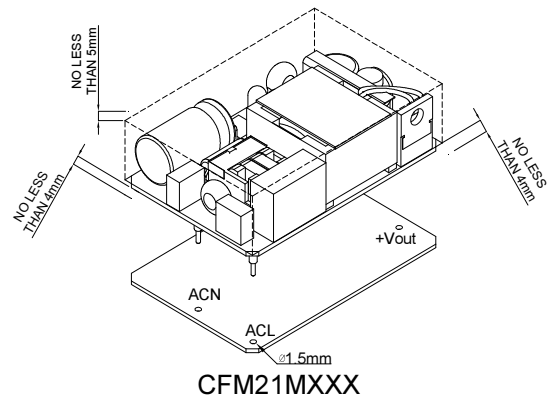

CFM21MXXX

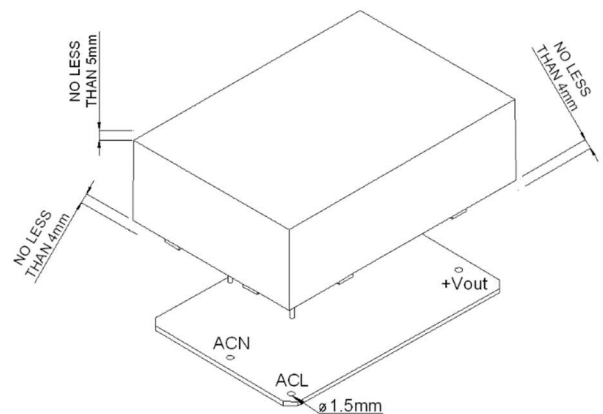

CFM21MXXX-E



# CFM21M Series

## Application Note V13 September 2020

### 8. Part Number

CFM XX M XXX-X

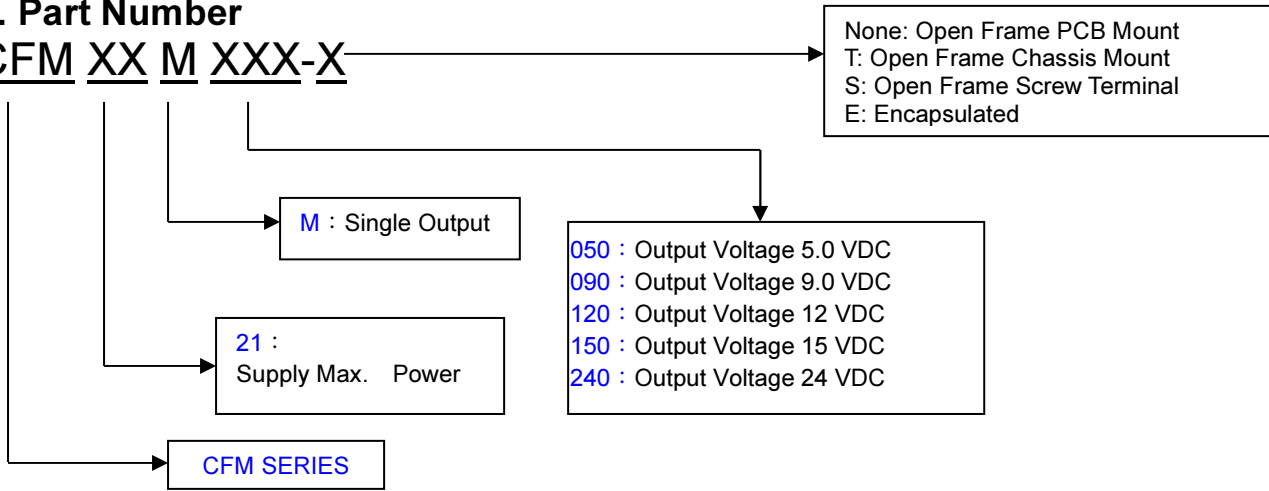





# CFM21M Series

## Application Note V13 September 2020

### 9. CFM21M Series Mechanical Outline Diagrams

#### 9.1. Mechanical Outline Diagrams

Annotations: For all models, height does not exceed 34mm max.

CFM21MXXX

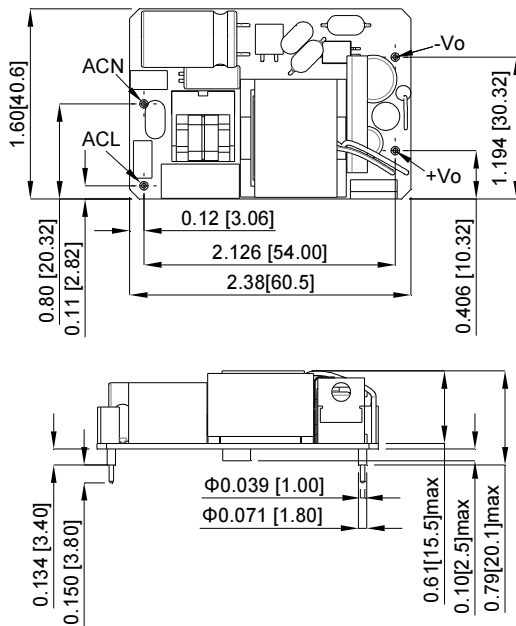

CFM21MXXX-T

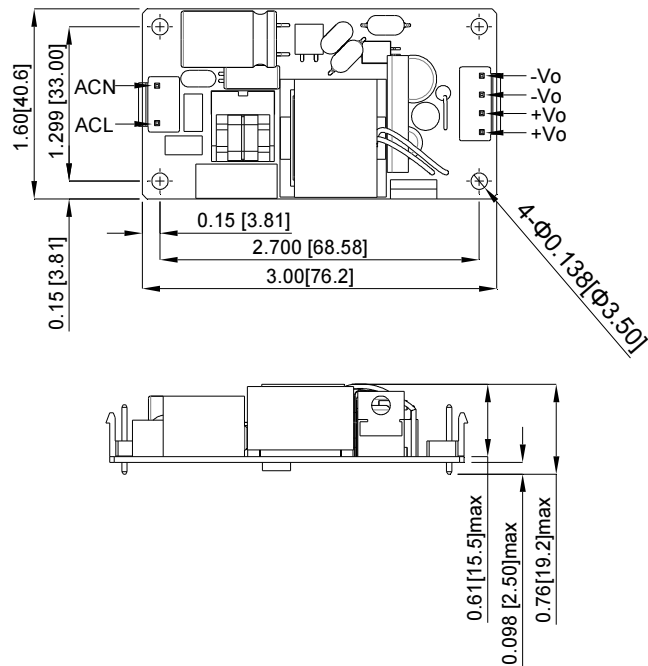

CFM21MXXX-E

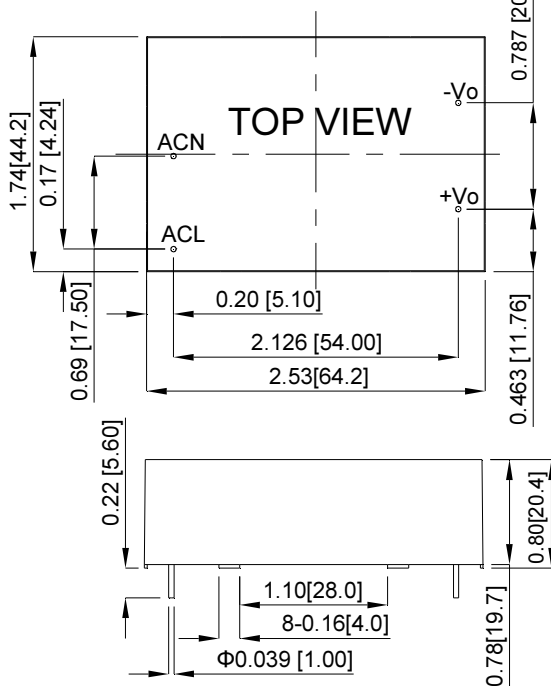

CFM21MXXX-S

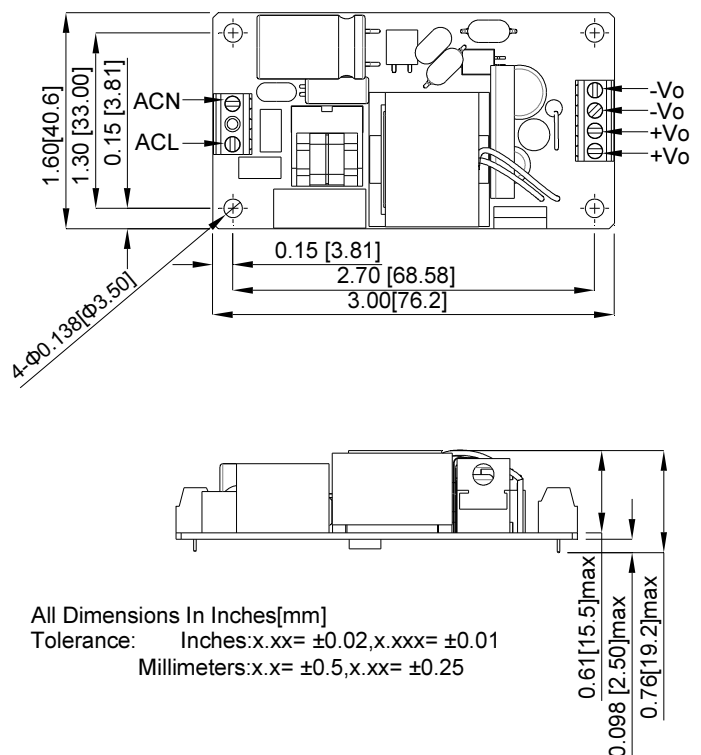

All Dimensions In Inches[mm]  
 Tolerance: Inches:x.xx= ±0.02,x.xxx= ±0.01  
 Millimeters:x.x= ±0.5,x.xx= ±0.25

Figure 3. CFM21M series Mechanical Outline Diagram



# CFM21M Series

## Application Note V13 September 2020

### 9.2. Packing Information

The CFM21MXXX series version are supplied in Boxed, full cartons with 100 modules per, including the total weight of package material about 6Kg. Details of Packaging dimensions are shown below

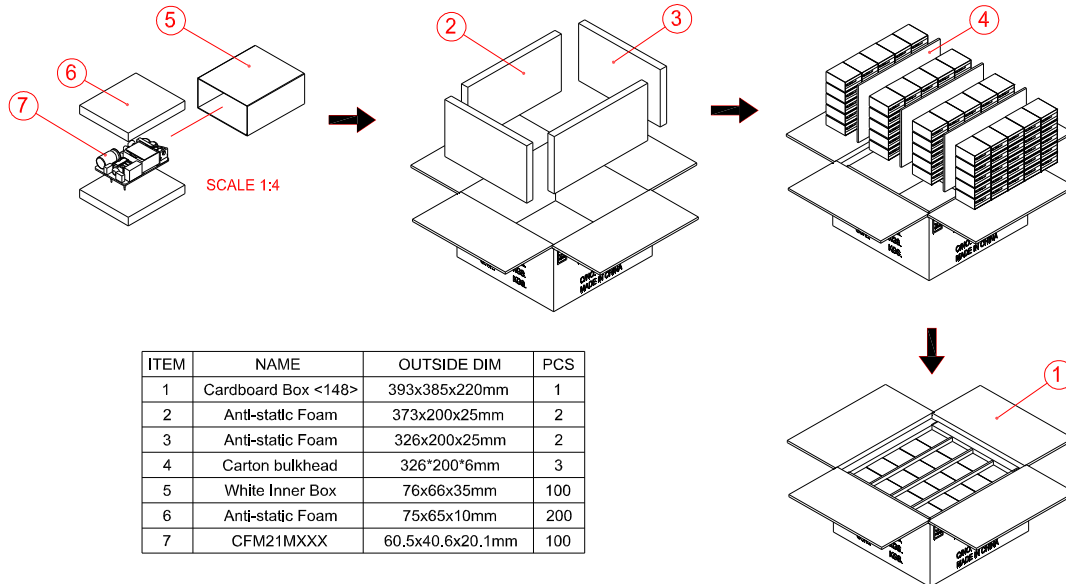

The CFM21MXXX-S series version are supplied in Boxed, full cartons with 50 modules per, including the total weight of package material about 3.5Kg, Details of Packaging dimensions are shown below

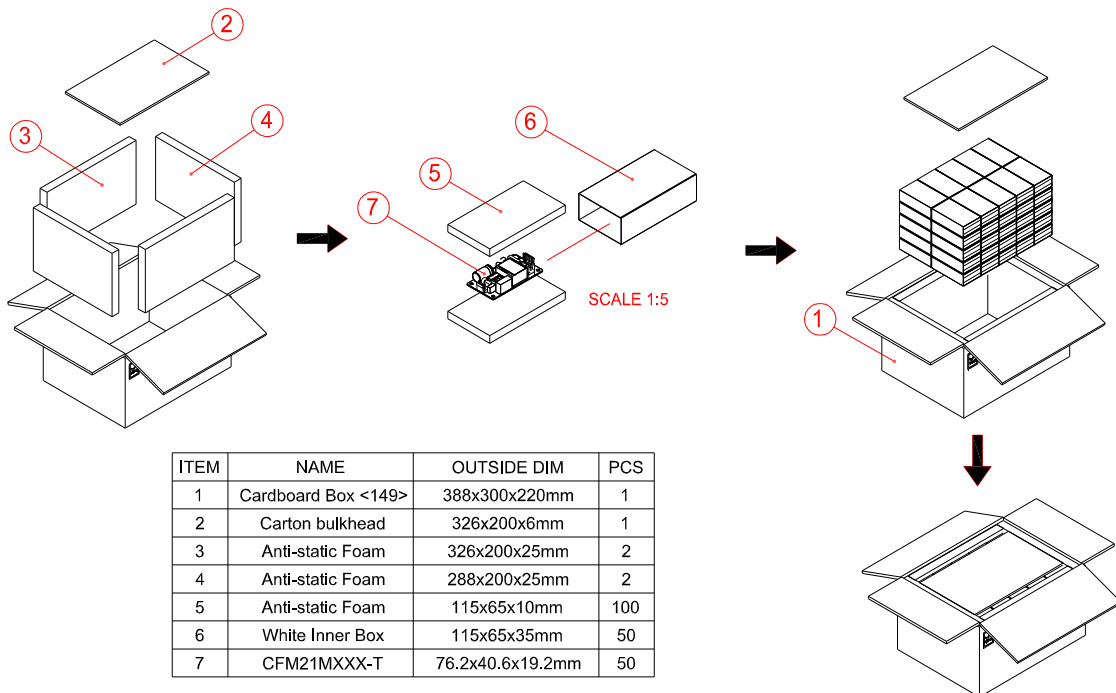



# CFM21M Series

## Application Note V13 September 2020

The CFM21MXXX-T series version are supplied in Boxed, full cartons with 50 modules per, including the total weight of package material about 3.5Kg, Details of Packaging dimensions are shown below

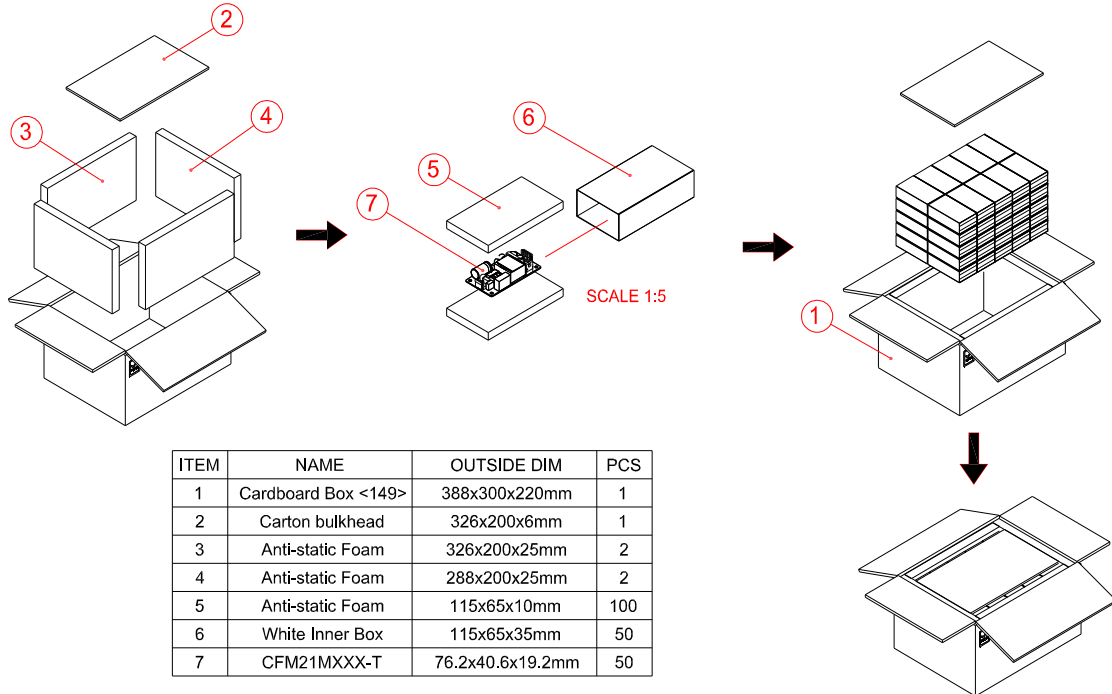

ITEM	NAME	OUTSIDE DIM	PCS
1	Cardboard Box <149>	388x300x220mm	1
2	Carton bulkhead	326x200x6mm	1
3	Anti-static Foam	326x200x25mm	2
4	Anti-static Foam	288x200x25mm	2
5	Anti-static Foam	115x65x10mm	100
6	White Inner Box	115x65x35mm	50
7	CFM21MXXX-T	76.2x40.6x19.2mm	50

The CFM21MXXX-E series version are supplied in Tube, Modules are shipped in quantities for CFM21MXXX-E of 11 modules per Tube, full cartons with 88 modules per, including the total weight of package material about 11Kg, Details of Packaging dimensions are shown below

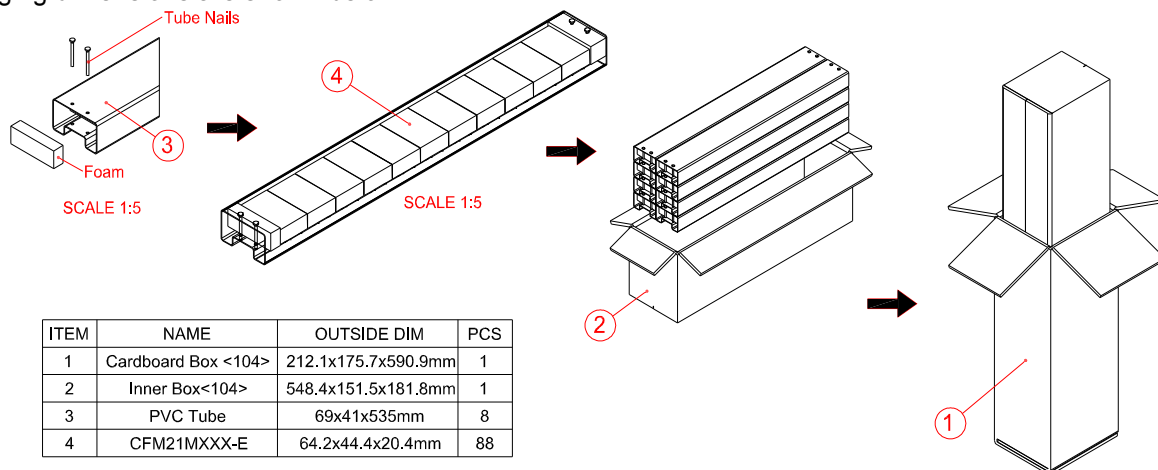

ITEM	NAME	OUTSIDE DIM	PCS
1	Cardboard Box <104>	212.1x175.7x590.9mm	1
2	Inner Box<104>	548.4x151.5x181.8mm	1
3	PVC Tube	69x41x535mm	8
4	CFM21MXXX-E	64.2x44.4x20.4mm	88

### CINCON ELECTRONICS CO., LTD.

#### Headquarters:

14F, No.306, Sec.4, Hsin Yi Rd.  
 Taipei, Taiwan  
 Tel: 886-2-27086210  
 Fax: 886-2-27029852  
 E-mail: [support@cincon.com.tw](mailto:support@cincon.com.tw)  
 Web Site: <http://www.cincon.com>

#### Factory:

No. 8-1, Fu Kung Rd.  
 Fu Hsing Industrial Park  
 Fu Hsing Hsiang,  
 Chang Hua Hsien, Taiwan  
 Tel: 886-4-7690261  
 Fax: 886-4-7698031

#### Cincon North America:

1655 Mesa Verde Ave. Ste 180  
 Ventura, CA 93003  
 Tel: 805-639-3350  
 Fax: 805-639-4101  
 E-mail: [info@cincon.com](mailto:info@cincon.com)