

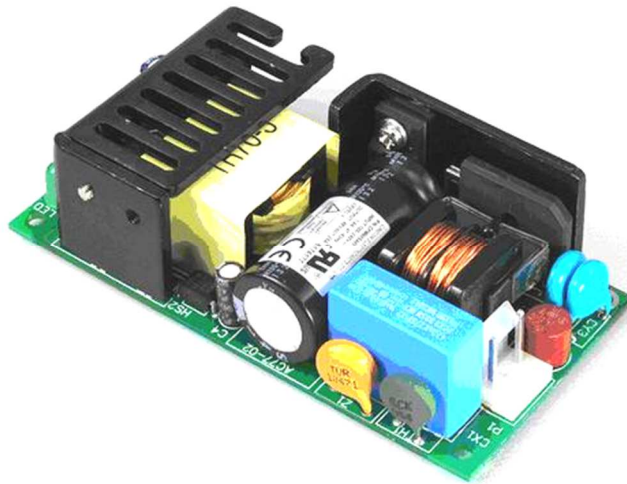

CFM40S Series Application Note V11

AC-DC Switching Power Module CFM40S Series APPLICATION NOTE



Approved By:

Department	Approved By	Checked By	Written By
Research and Development Department	Ovid	Yang	Pei Xun
Design Quality Department	Benny	JoJo	



CFM40S Series

Application Note V11

Content

1. INTRODUCTION	3
2. ELECTRICAL BLOCK DIAGRAM	3
3. MAIN FEATURES AND FUNCTIONS	4
3.1 <i>Operating Temperature Range</i>	4
3.2 <i>Output Protection</i>	4
4. APPLICATIONS	4
4.1 <i>Test Set-Up</i>	4
4.2 <i>Output Ripple and Noise Measurement</i>	4
4.3 <i>Installation Instruction</i>	5
5. PACKING INFORMATION	6



CFM40S Series

Application Note V11

1. Introduction

This application note describes the features and functions of Cincon's CFM40S series of open frame, switching AC-DC power module. These are highly efficient, reliable, compact, high power density, single output AC/DC power modules. The module is fully protected against short circuit and over-voltage conditions. Cincon's world class automated manufacturing methods, together with an extensive testing and qualification program, ensure that the CFM40S series power module is extremely reliable.

2. Electrical Block Diagram

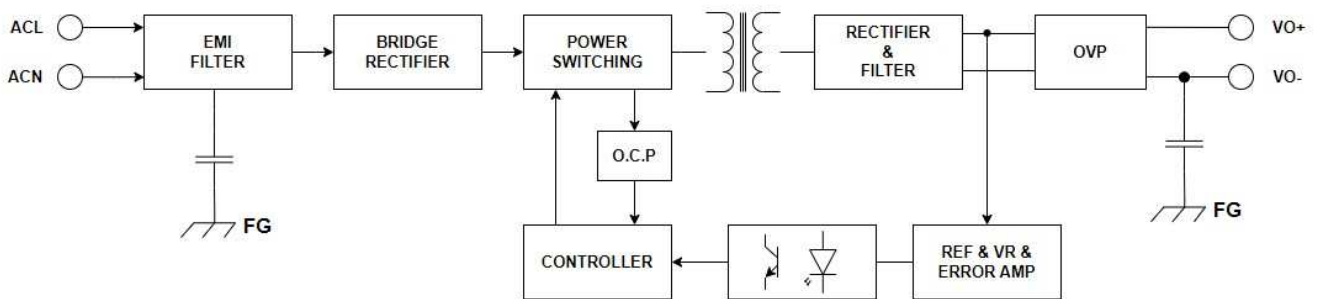



CFM40S Series

Application Note V11

3. Main Features and Functions

3.1 Operating Temperature Range

The highly efficient design of Cincon's CFM40S series power modules has resulted in their ability to operate within ambient temperature environments from 0°C to 70°C. Due consideration must be given to the de-rating curves when ascertaining the maximum power that can be drawn from the module. The maximum power which can be drawn is influenced by a number of factors, such as:

- Input voltage range
- Permissible Output load (per derating curve)
- Effective heat sinks

3.2 Output Protection

The power modules provide full continuous short-circuit protection. The unit will auto recover once the short circuit is removed. To provide protection in a fault condition, the unit is equipped with internal over-current protection. The unit will operate normally once the fault condition is removed. The power module will go to hiccup mode if the output current is set from 120% to 180% of rated current.

4. Applications

4.1 Test Set-Up

The basic test set-up to measure parameters such as efficiency and load regulation is shown in Figure 1. When testing the Cincon's CFM40S series under any transient conditions, please ensure that the transient response of the source is sufficient to power the equipment under test. We can calculate the

- Efficiency
- Load regulation and line regulation.

The value of efficiency is defined as:

$$\eta = \frac{V_o \times I_o}{P_{in}} \times 100\%$$

Where:

- Vo is output voltage
- Io is output current
- Pin is input power

The value of load regulation is defined as:

$$Load\ reg. = \frac{V_{FL} - V_{NL}}{V_{NL}} \times 100\%$$

Where:

- V_{FL} is the output voltage at 100% full load
- V_{NL} is the output voltage at 10% load

The value of line regulation is defined as:

$$Line\ reg. = \frac{V_{HL} - V_{LL}}{V_{LL}} \times 100\%$$

Where:

- V_{HL} is the output voltage of maximum input voltage at 100% full load
- V_{LL} is the output voltage of minimum input voltage at 100% full load

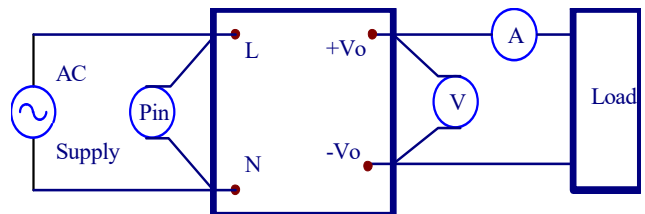

Figure 1. CFM40S Series Test Setup

4.2 Output Ripple and Noise Measurement

The test set-up for noise and ripple measurements is shown in Figure 2. Measured method:

Add a C2: 0.1uF ceramic capacitor and a C1: 10uF electrolytic capacitor to output at 20 MHz Band Width.

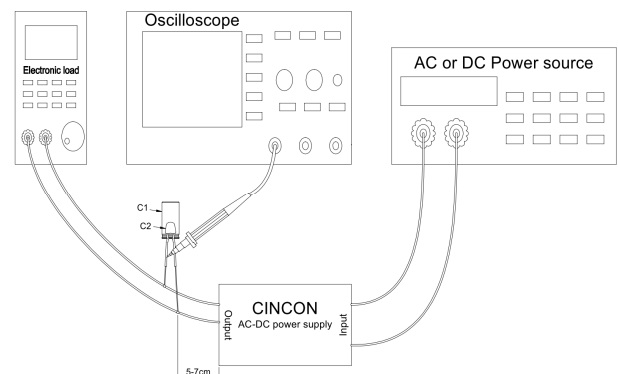

Figure 2. Output Voltage Ripple and Noise Measurement Set-Up



CFM40S Series

Application Note V11

4.3 Installation Instruction

The CFM40S series has four 3.17mm diameter mounting holes. Please use the mounting holes as follows:

Insert the spacer (6mm diameter max.) of 8mm height or more to mount the unit. The vibration specification applies when the unit is mounted on 8mm spacers

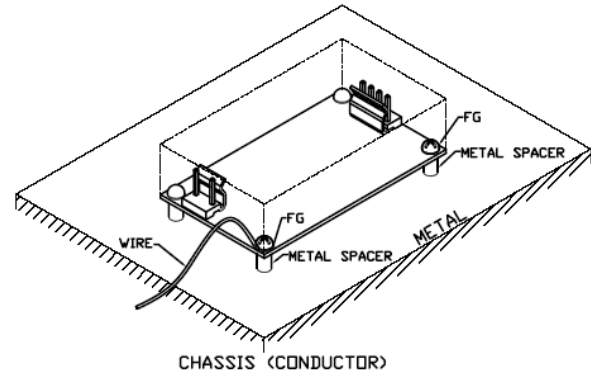
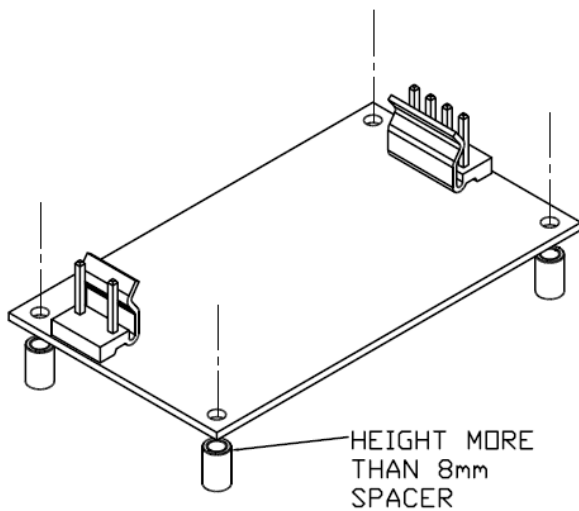

Please allow 4mm side clearance from the components and all side of the PCB. Allow 5mm clearance above the highest parts on the PCB. Be especially careful to allow 8mm between the solder side of the PCB and the mounting surface. If the clearances are not sufficient, the specifications for isolation and withstand will not be valid.

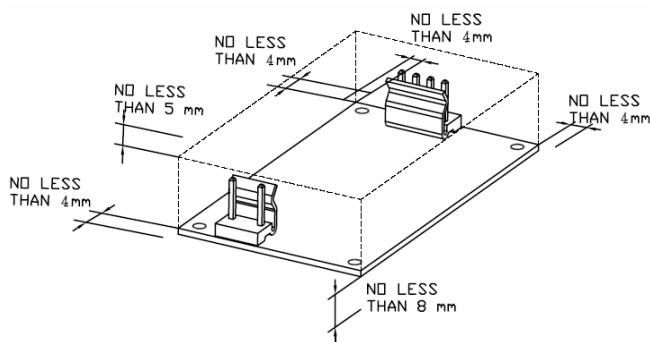

FG should be connected to the earth (ground) terminal of the apparatus. If not, the conducted noise and output noise will increase.



CFM40S Series

Application Note V11

5. Packing Information

The packing information for CFM40SXXX series is showing as follows:

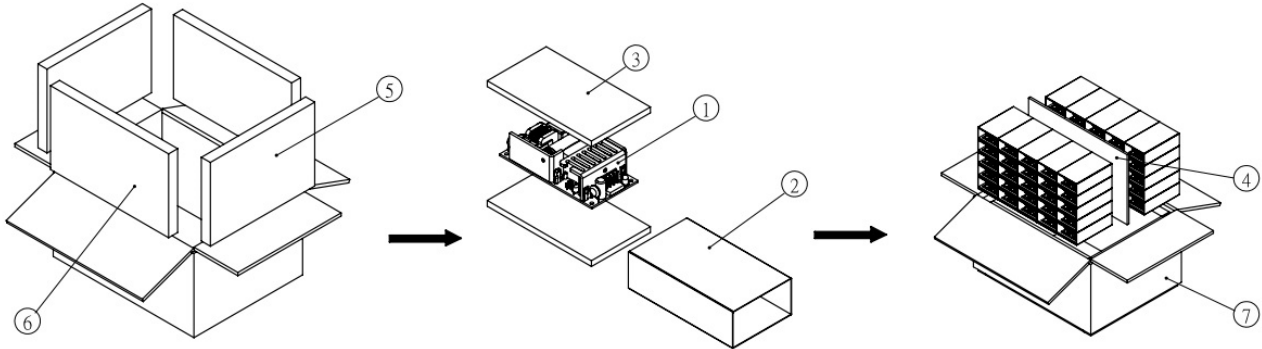

ITEM	PART NO.	NAME	OUTSIDE DIM(mm)	PCS
1		CFM40SXXX	101.6x50.8x30.48	50
2	G64304165	Inner Box	115x65x35	50
3	G64308313	Antistatic Foma	115x65x5.5	100
4	G64U10075	Partition	326x200x6	1
5	G64301115	Antistatic Foam	288x200x25	2
6	G64301114	Antistatic Foam	326x200x25	2
7	G64114347	No.149 Cardboard Box	388x300x220	1

Each Box Packaging 50 PCS Products
Gross weight Ref. 10.5 Kg

The packing information for CFM40SXXX-P series is showing as follows:

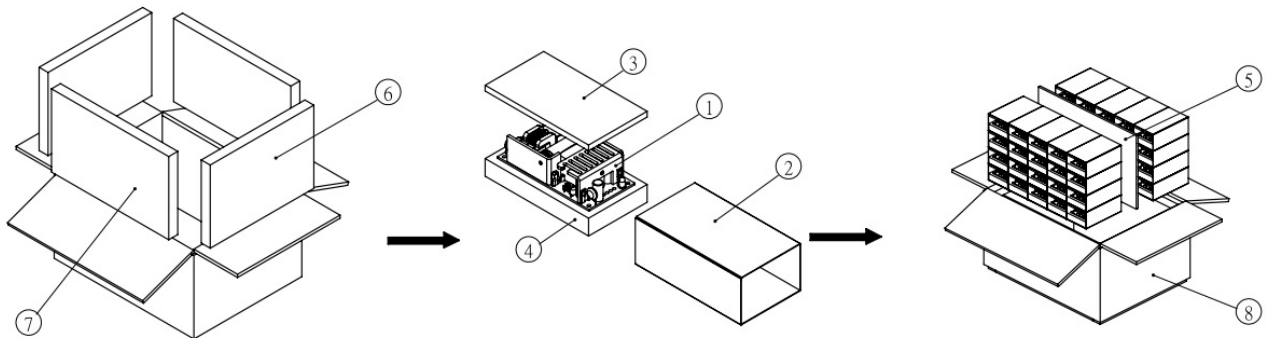

ITEM	PART NO.	NAME	OUTSIDE DIM(mm)	PCS
1		CFM40SXXX-P	101.6x50.8x32.38	40
2	G64304161	Inner Box	115x65x45	40
3	G64308313	Antistatic Foma	115x65x5.5	40
4	G64308309	Antistatic Foma	115x65x17	40
5	G64U10075	Partition	326x200x6	1
6	G64301115	Antistatic Foam	288x200x25	2
7	G64301114	Antistatic Foam	326x200x25	2
8	G64114347	No.149 Cardboard Box	388x300x220	1

Each Box Packaging 40 PCS Products
Gross weight Ref. 8.8 Kg



CFM40S Series

Application Note V11

The packing information for CFM40SXXX-CA series is showing as follows:

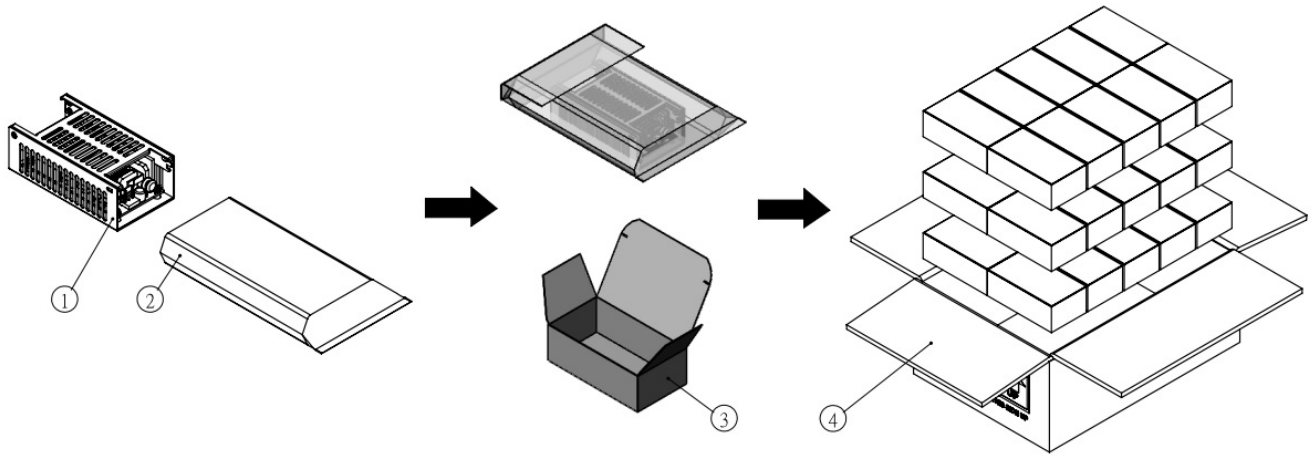

ITEM	PART NO.	NAME	OUTSIDE DIM(mm)	PCS
1		CFM40SXXX-CA	117x62x40	30
2	G64D15057	Plastic Bag	245x155x0.08	30
3	G64304071	Inner Box	121.5x66x42	30
4	G64112339	No.59 Cardboard Box	360.6x257.6x148.5	1

Each Box Packaging 30 PCS Products
Gross weight Ref. 8 Kg

CINCON ELECTRONICS CO., LTD.

Headquarters:

14F, No.306, Sec.4, Hsin Yi Rd.
Taipei, Taiwan
Tel: 886-2-27086210
Fax: 886-2-27029852
E-mail: sales@cincon.com.tw
Web Site: <https://www.cincon.com>

Factory:

No. 8-1, Fu Kung Rd.
Fu Hsing Industrial Park
Fu Hsing Hsiang,
Chang Hua Hsien, Taiwan
Tel: 886-4-7690261
Fax: 886-4-7698031

Cincon North America:

1655 Mesa Verde Ave. Ste 180
Ventura, CA 93003
Tel: 805-639-3350
Fax: 805-639-4101
E-mail: info@cincon.com