

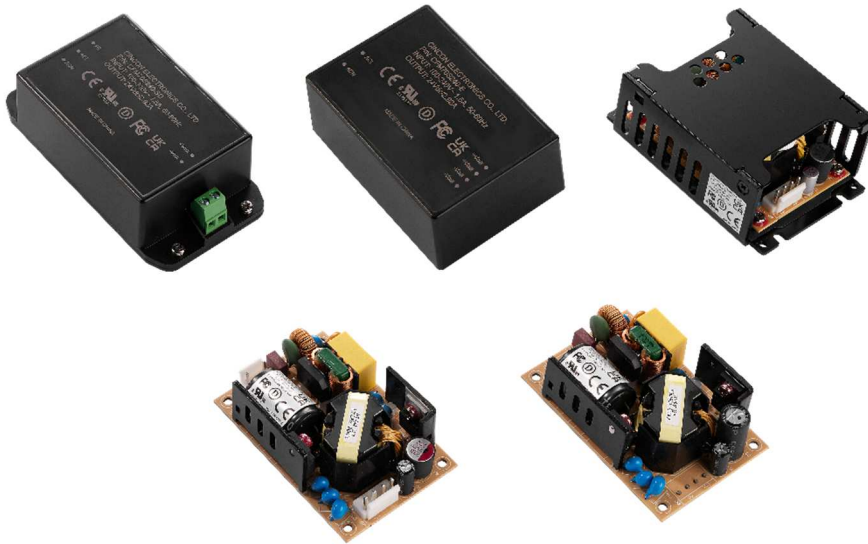

CFM70S Series

Application Note V12

AC-DC Switching Power Module CFM70S Series APPLICATION NOTE



Approved By:

Department	Approved By	Checked By	Written By
Research and Development Department	Ovid	Wei-Cheng	Jason
Design Quality Department	Benny	JoJo	



CFM70S Series

Application Note V12

Content

1. INTRODUCTION	3
2. ELECTRICAL BLOCK DIAGRAM	3
3. MAIN FEATURES AND FUNCTIONS	4
3.1 <i>Operating Temperature Range</i>	4
3.2 <i>Output Protection</i>	4
4. APPLICATIONS	4
4.1 <i>Test Set-Up</i>	4
4.2 <i>Output Ripple and Noise Measurement</i>	4
4.3 <i>Installation Instruction</i>	5
5. PACKING INFORMATION	7



CFM70S Series

Application Note V12

1. Introduction

This application note describes the features and functions of Cincon's CFM70S series of open frame, switching AC-DC power module. These are highly efficient, reliable, compact, high power density, single output AC/DC power modules. The module is fully protected against short circuit and over-voltage conditions. Cincon's world class automated manufacturing methods, together with an extensive testing and qualification program, ensure that the CFM70S series power module is extremely reliable.

2. Electrical Block Diagram

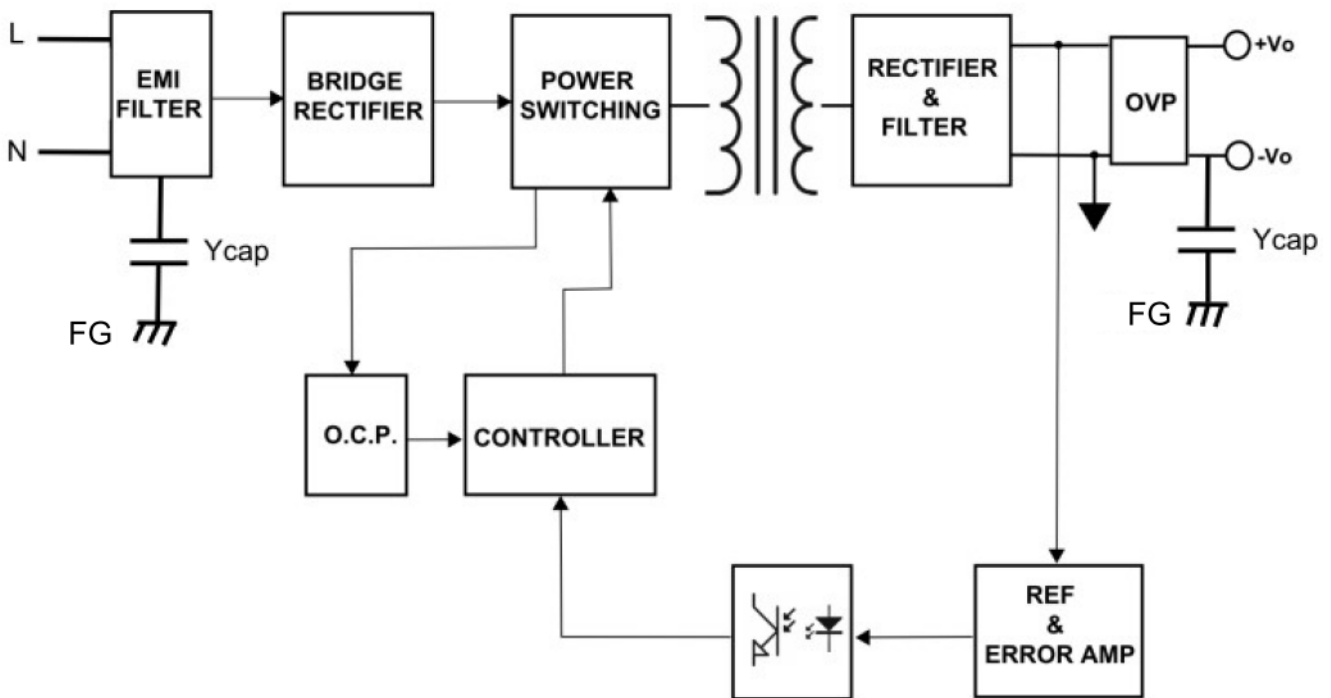



CFM70S Series

Application Note V12

3. Main Features and Functions

3.1 Operating Temperature Range

The highly efficient design of Cincon's CFM70S series power modules has resulted in their ability to operate within ambient temperature environments from -30°C to 80°C, -40°C can be start up. Due consideration must be given to the de-rating curves when ascertaining the maximum power that can be drawn from the module. The maximum power which can be drawn is influenced by a number of factors, such as:

- Input voltage range
- Permissible output load (per derating curve)

3.2 Output Protection

The power modules provide full continuous short-circuit protection. The unit will auto recover once the short circuit is removed. To provide protection in a fault condition, the unit is equipped with internal over-current protection. The unit will operate normally once the fault condition is removed.

4. Applications

4.1 Test Set-Up

The basic test set-up to measure parameters such as efficiency and load regulation is shown in Figure 1. When testing the Cincon's CFM70S series under any transient conditions, please ensure that the transient response of the source is sufficient to power the equipment under test. We can calculate the

- Efficiency
- Load regulation and line regulation

The value of efficiency is defined as:

$$\eta = \frac{V_o \times I_o}{P_{in}} \times 100\%$$

Where:

- Vo is output voltage
- Io is output current
- Pin is input power

The value of load regulation is defined as:

$$Load\ reg. = \frac{V_{FL} - V_{NL}}{V_{NL}} \times 100\%$$

Where:

V_{FL} is the output voltage at full load

V_{NL} is the output voltage at 10% load

The value of line regulation is defined as:

$$Line\ reg. = \frac{V_{HL} - V_{LL}}{V_{LL}} \times 100\%$$

Where:

V_{HL} is the output voltage of maximum input voltage at full load.

V_{LL} is the output voltage of minimum input voltage at full load.

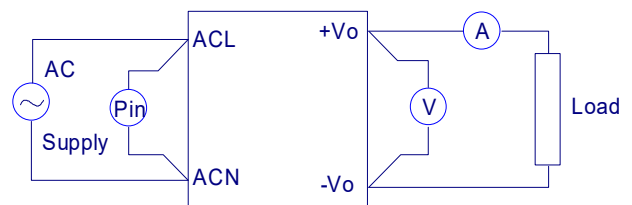

Figure 1. CFM70S Series Test Setup

4.2 Output Ripple and Noise Measurement

The test set-up for noise and ripple measurements is shown in Figure 2 Measured method:

Add a 0.1 uF ceramic capacitor and a 10 uF electrolytic capacitor to output at 20 MHz Band Width.

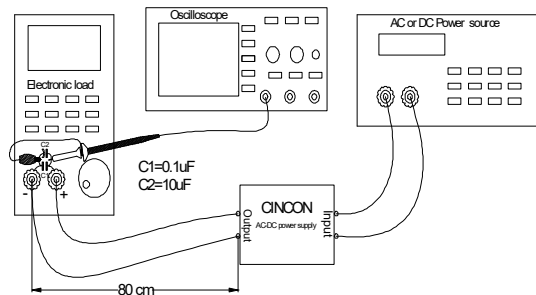

Figure 2. Output Voltage Ripple and Noise Measurement Set-Up



CFM70S Series

Application Note V12

4.3 Installation Instruction

Please use the mounting hold as:
 CFM70S series: 4 holds of $\Phi 3.17$ and insert the spacer (Max $\Phi 6$) of height over 8mm to lift the unit. The vibration spec. is the value take when the unit is raised by 8mm spacers.

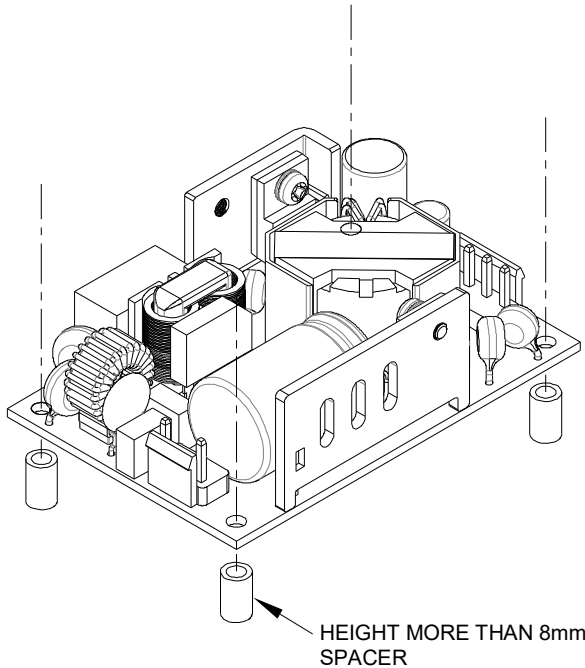

Please reserve 4mm space from the surfaces and the sides of PCB, especially from the solder surface, 8mm space is necessary. If the space is not enough, the specification of insulation and withstand will not be satisfied.

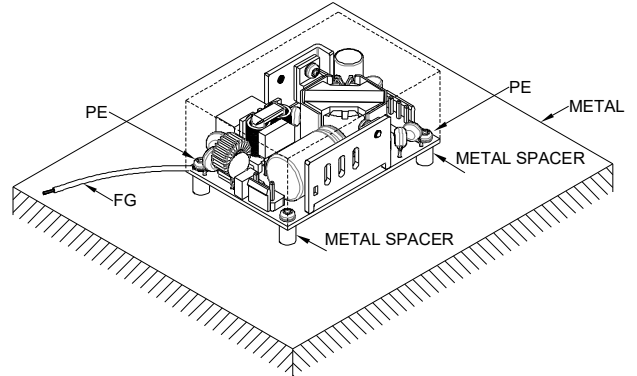
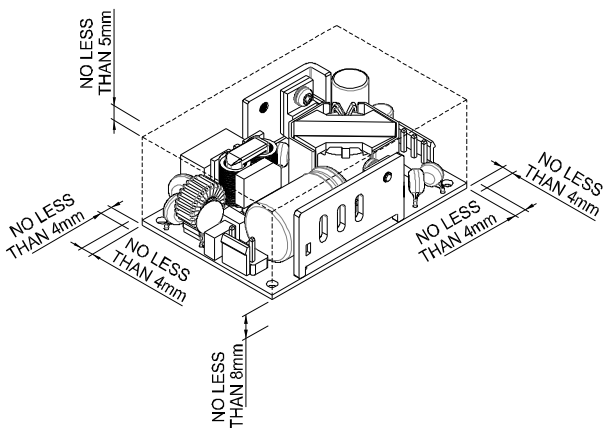

The CFM70SXXX-P mounting holes are 1.5mm. Please allow 4mm side clearance from the components and all side of the PCB. Allow 5mm clearance above the highest parts on the PCB.

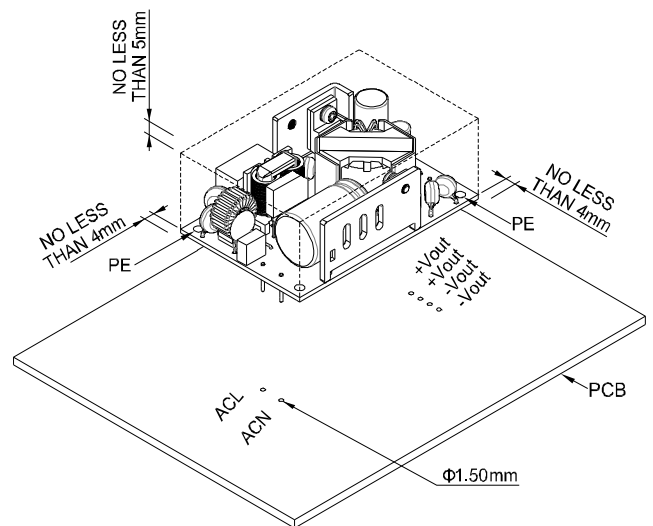

CFM70SXXX-P installation diagram

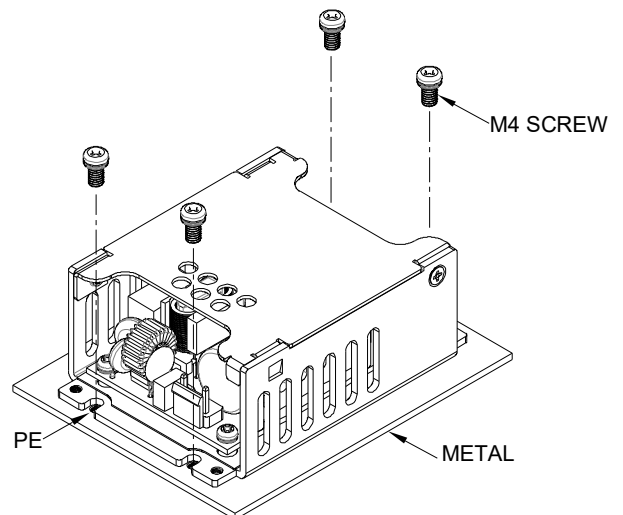



CFM70S Series

Application Note V12

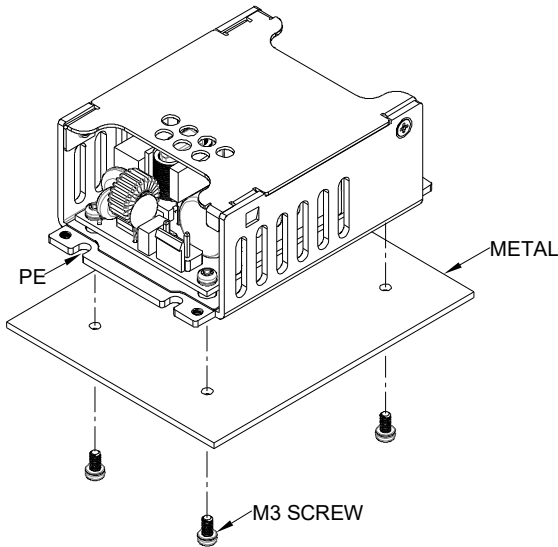

CFM70SXXX-CA installation diagram

Note1:

M3&M4 screw head and washer diameter shall not exceed 5.5mm

Note2:

Recommended torque value of M3 threaded hole: 4kgf-cm (Max.)

Please allow 4mm side clearance from the components and all side of the PCB. Allow 5mm clearance above the highest parts on the PCB. Be especially careful to allow 5mm between the solder side of the PCB and the mounting surface. If the clearances are not sufficient the specifications for isolation and withstand will not be valid.

The CFM70SXXX-E mounting holes are 1.8mm. Please allow 4mm side clearance from the components and all side of the PCB and CASE. Allow 5mm clearance above the highest parts on the PCB and CASE.

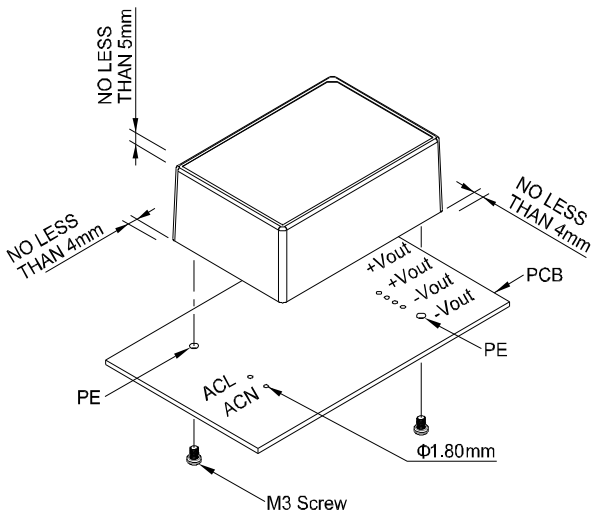

CFM70SXXX-E installation diagram

Note:

Recommended torque value of M3 threaded hole: 4kgf-cm (Max.)

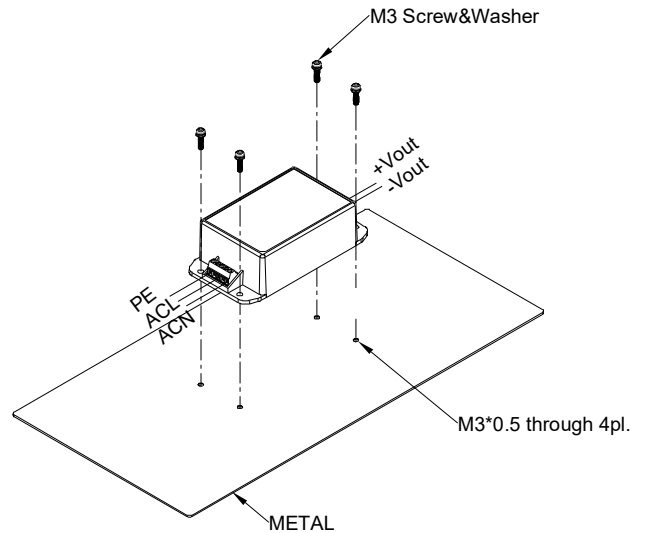

CFM70SXXX-S installation diagram

Note:

Recommended torque value of M3 threaded hole: 4kgf-cm (Max.)

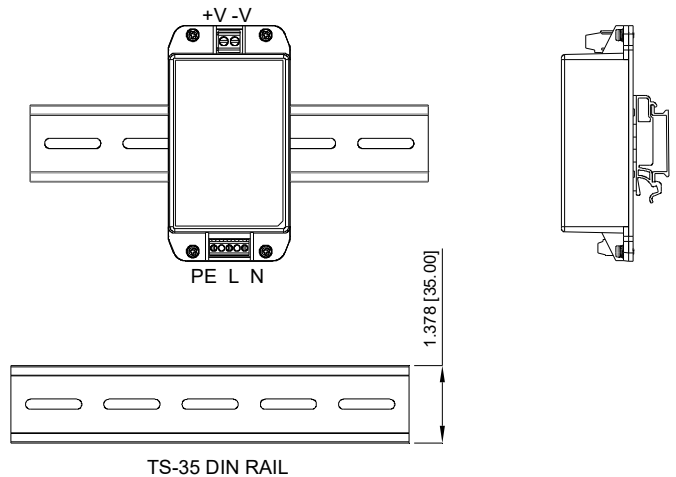

CFM70SXXX-SD installation diagram

FG should be connected to the earth (ground) terminal of the apparatus. If not, the conducted noise and output noise will increase.



CFM70S Series

Application Note V12

5. Packing Information

The packing information for CFM70SXXX series

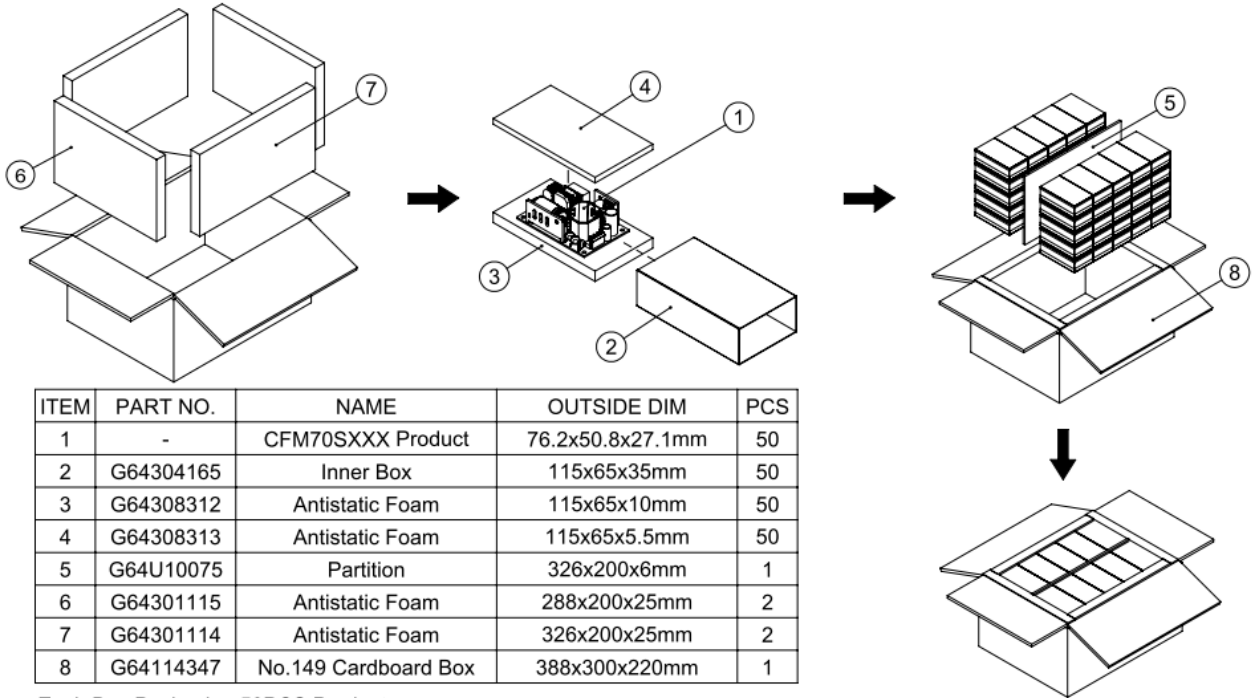

ITEM	PART NO.	NAME	OUTSIDE DIM	PCS
1	-	CFM70SXXX Product	76.2x50.8x27.1mm	50
2	G64304165	Inner Box	115x65x35mm	50
3	G64308312	Antistatic Foam	115x65x10mm	50
4	G64308313	Antistatic Foam	115x65x5.5mm	50
5	G64U10075	Partition	326x200x6mm	1
6	G64301115	Antistatic Foam	288x200x25mm	2
7	G64301114	Antistatic Foam	326x200x25mm	2
8	G64114347	No.149 Cardboard Box	388x300x220mm	1

Each Box Packaging 50PCS Products
Gross Weight Ref. 6.2Kg

CFM70SXXX 50pcs a box, including the total weight of package material about 6.2Kg

The packing information for CFM70SXXX-P series

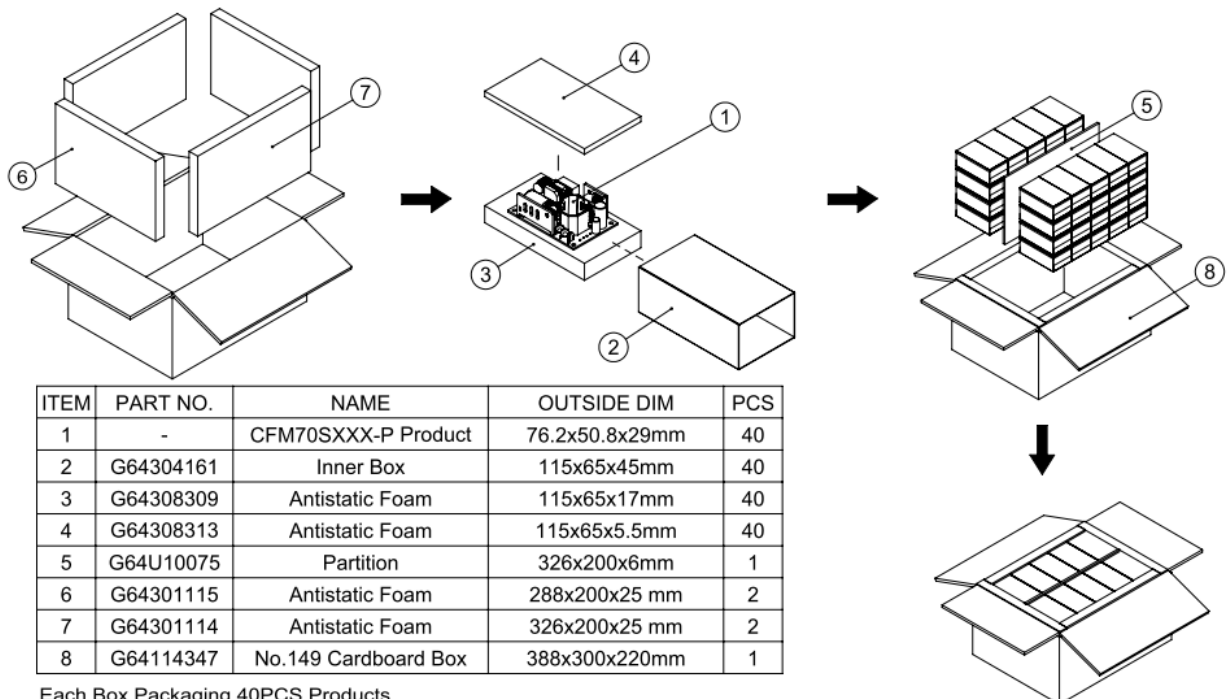

ITEM	PART NO.	NAME	OUTSIDE DIM	PCS
1	-	CFM70SXXX-P Product	76.2x50.8x29mm	40
2	G64304161	Inner Box	115x65x45mm	40
3	G64308309	Antistatic Foam	115x65x17mm	40
4	G64308313	Antistatic Foam	115x65x5.5mm	40
5	G64U10075	Partition	326x200x6mm	1
6	G64301115	Antistatic Foam	288x200x25 mm	2
7	G64301114	Antistatic Foam	326x200x25 mm	2
8	G64114347	No.149 Cardboard Box	388x300x220mm	1

Each Box Packaging 40PCS Products
Gross Weight Ref. 5.2Kg

CFM70SXXX-P 40 pcs a box, including the total weight of package material about 5.2Kg



CFM70S Series

Application Note V12

The packing information for CFM70SXXX-CA series

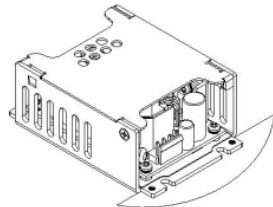

Detail Enlargement A

ITEM	PART NO.	NAME	OUTSIDE DIM	PCS
1	-	CFM70SXXX-CA Product	91.4x64x34.5mm	48
2	G64301210	Antistatic Foam	485x330x50mm	4
3	G64301208	Antistatic Foam	485x330x15mm	2
4	G64100099	No.49 Cardboard Box	500x345x260mm	1

Each Box Packaging 48 PCS Products
Gross weight Ref. 10.0 Kg

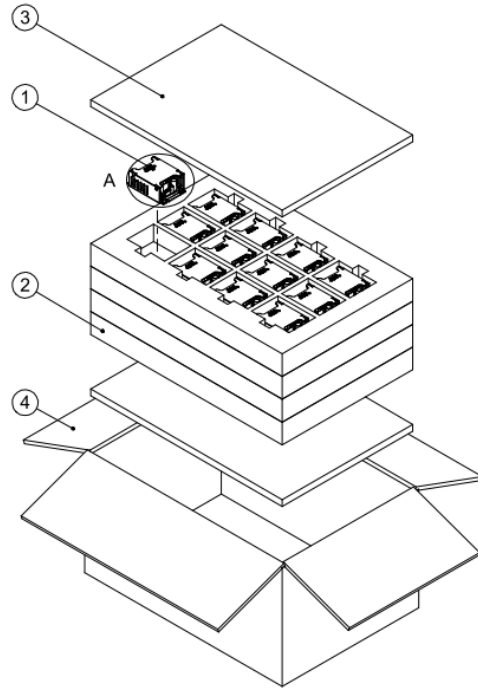

CFM70SXXX-CA 48 pcs a box, including the total weight of package material about 10Kg

The packing information for CFM70SXXX-E series

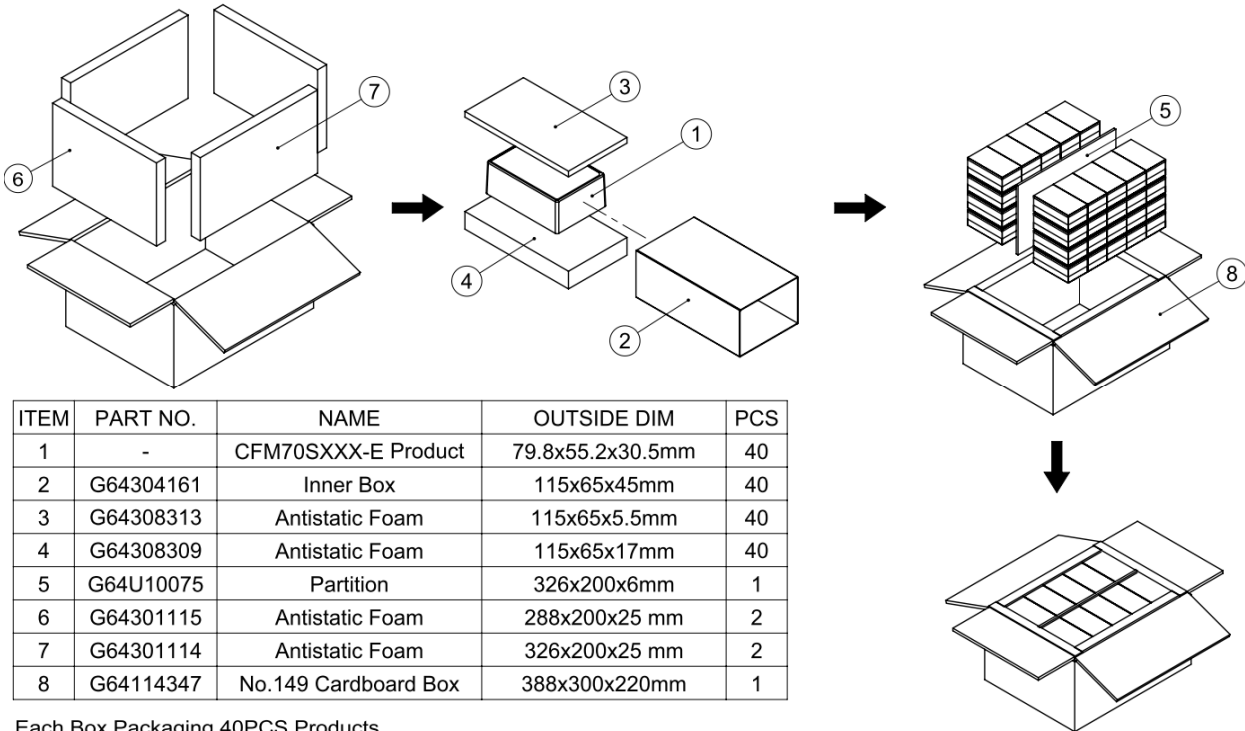

ITEM	PART NO.	NAME	OUTSIDE DIM	PCS
1	-	CFM70SXXX-E Product	79.8x55.2x30.5mm	40
2	G64304161	Inner Box	115x65x45mm	40
3	G64308313	Antistatic Foam	115x65x5.5mm	40
4	G64308309	Antistatic Foam	115x65x17mm	40
5	G64U10075	Partition	326x200x6mm	1
6	G64301115	Antistatic Foam	288x200x25 mm	2
7	G64301114	Antistatic Foam	326x200x25 mm	2
8	G64114347	No.149 Cardboard Box	388x300x220mm	1

Each Box Packaging 40PCS Products
Gross Weight Ref. 10.4Kg

CFM70SXXX-E 40 pcs a box, including the total weight of package material about 10.4Kg



CFM70S Series

Application Note V12

The packing information for CFM70SXXX-S(D) series

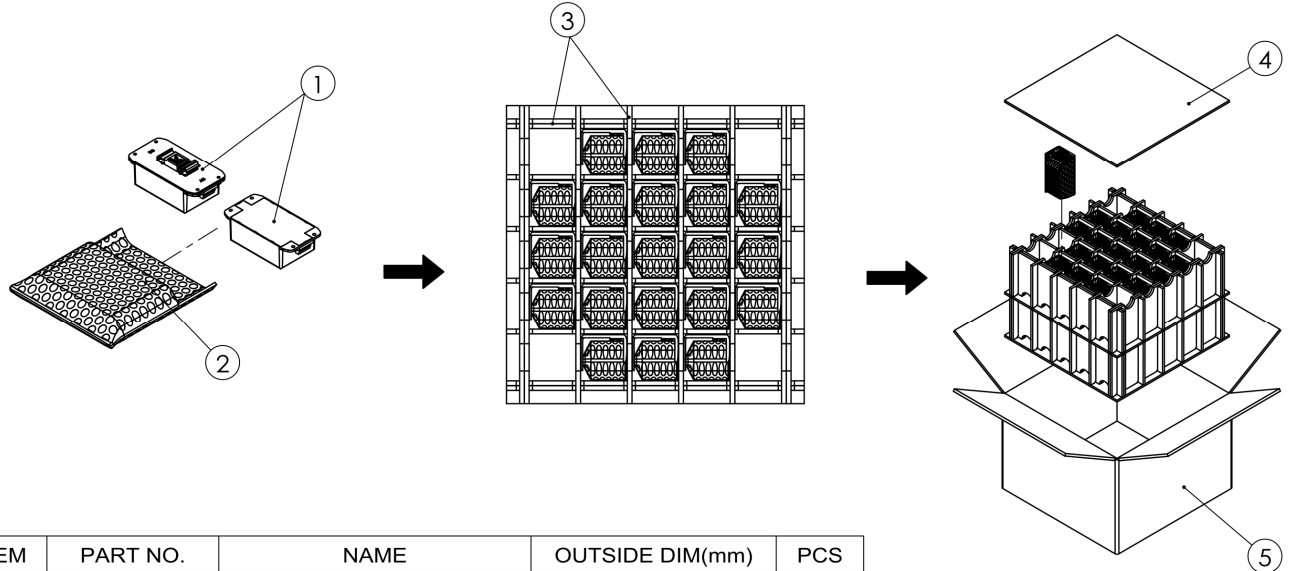

ITEM	PART NO.	NAME	OUTSIDE DIM(mm)	PCS
1	-	CFM70SXXX-S Product CFM70SXXX-SD Product	106.6x55.2x30.5 106.6x55.2x45.3	42
2	G64F00005	Antistatic Bag	165x(110+60)	42
3	G64U10045	Partition	440x142x7	32
4	G64U13046	Partition	440x440x6	3
5	G64114295	No.116 Cardboard Box	455x455x321	1

Each Box Packaging 42PCS Products
CFM70SXXX-S
Gross weight Ref. 11.9 Kg
CFM70SXXX-SD
Gross weight Ref. 15.9 Kg

CFM70SXXX-S 42 pcs a box, including the total weight of package material about 11.9Kg
CFM70SXXX-SD 42 pcs a box, including the total weight of package material about 15.9Kg

CINCON ELECTRONICS CO., LTD.

Headquarters:

14F, No.306, Sec.4, Hsin Yi Rd.
Taipei, Taiwan
Tel: 886-2-27086210
Fax: 886-2-27029852
E-mail: sales@cincon.com.tw
Web Site: <https://www.cincon.com>

Factory:

No. 8-1, Fu Kung Rd.
Fu Hsing Industrial Park
Fu Hsing Hsiang,
Chang Hua Hsien, Taiwan
Tel: 886-4-7690261
Fax: 886-4-7698031

Cincon North America:

1655 Mesa Verde Ave. Ste 180
Ventura, CA 93003
Tel: 805-639-3350
Fax: 805-639-4101
E-mail: info@cincon.com