

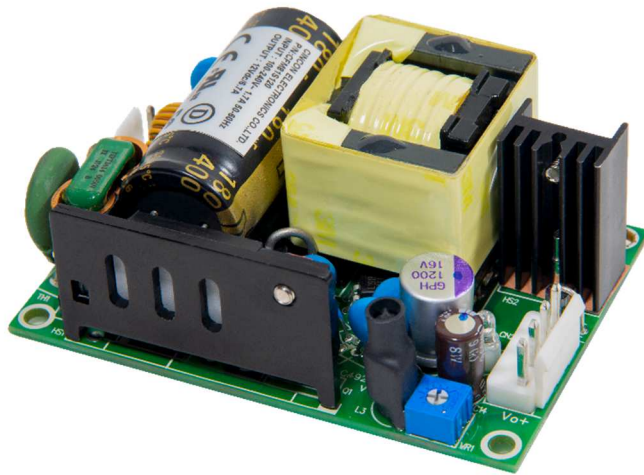

CFM81S Series

Application Note V10

AC-DC Switching Power Module CFM81S Series APPLICATION NOTE



Approved By:

Department	Approved By	Checked By	Written By
Research and Development Department	Enoch	Yang	Jason
		Ovid	
Quality Assurance Department	Ryan	Benny	



CFM81S Series

Application Note V10

Content

1. INTRODUCTION	3
2. ELECTRICAL BLOCK DIAGRAM	3
3. MAIN FEATURES AND FUNCTIONS	4
3.1 <i>Operating Temperature Range</i>	4
3.2 <i>Output Protection</i>	4
3.3 <i>Peak Load Function</i>	4
4. APPLICATIONS	4
4.1 <i>Test Set-Up</i>	4
4.2 <i>Output Ripple and Noise Measurement</i>	4
4.3 <i>Installation Instruction</i>	5
5. PACKING INFORMATION	6



CFM81S Series

Application Note V10

1. Introduction

This application note describes the features and functions of Cincon's CFM81S series of open frame, switching AC-DC power module. These are highly efficient, reliable, compact, high power density, single output AC/DC power modules. The module is fully protected against short circuit and over-voltage conditions. Cincon's world class automated manufacturing methods, together with an extensive testing and qualification program, ensure that the CFM81S series power module is extremely reliable.

2. Electrical Block Diagram

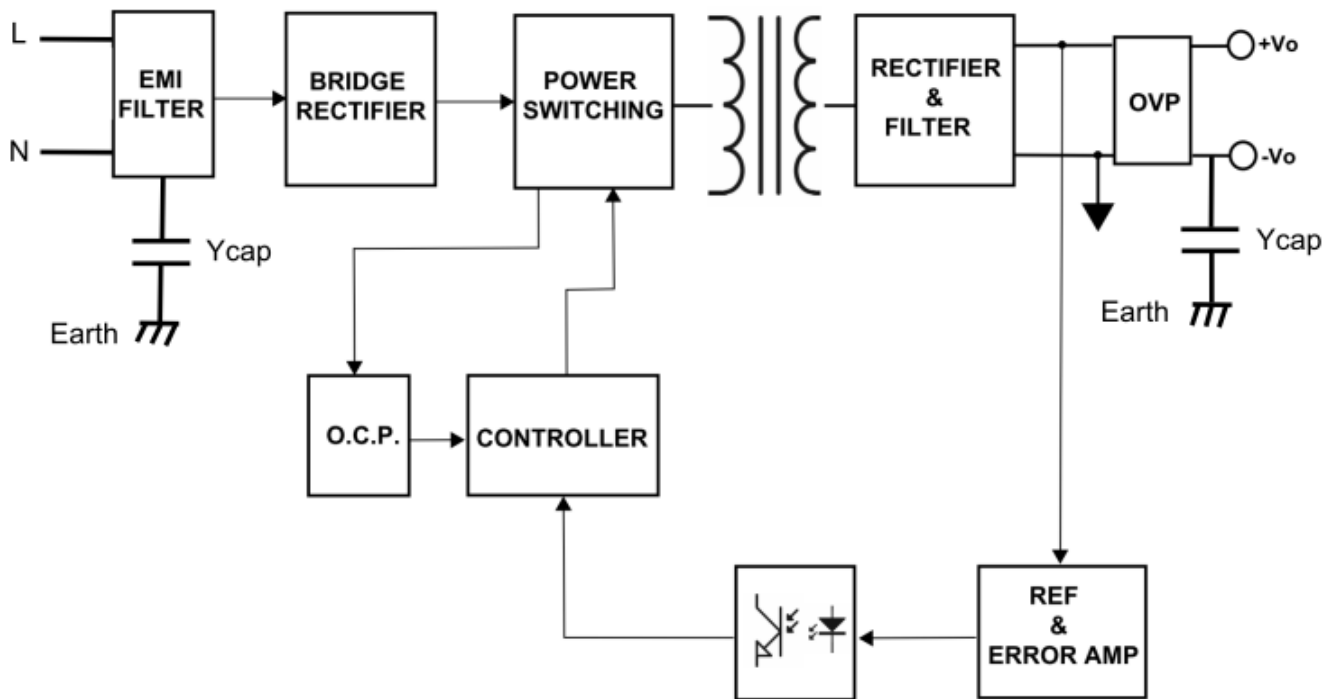



CFM81S Series

Application Note V10

3. Main Features and Functions

3.1 Operating Temperature Range

The highly efficient design of Cincon's CFM81S series power modules has resulted in their ability to operate within ambient temperature environments from -30°C to 80°C, -40°C can be start up. Due consideration must be given to the de-rating curves when ascertaining the maximum power that can be drawn from the module. The maximum power which can be drawn is influenced by a number of factors, such as:

- Input voltage range
- Permissible output load (per derating curve)

3.2 Output Protection

The power modules provide full continuous short-circuit protection. The unit will auto recover once the short circuit is removed. To provide protection in a fault condition, the unit is equipped with internal over-current protection. The unit will operate normally once the fault condition is removed.

3.3 Peak Load Function

CFM81SXXX has a very powerful peak load function which can provide twice the rated power. About OCP(Over Current Protection) of this power modules is set at 200% rated load. The peak load function lasting time < 10 seconds, with a maximum 10% duty cycle. When operating peak load function, it requires the average power do not exceed 75.08% rated power.

Vin=100Vac&115Vac&230Vac&264Vac

Peak load function by 200% load 10S & 61.2% load 90S

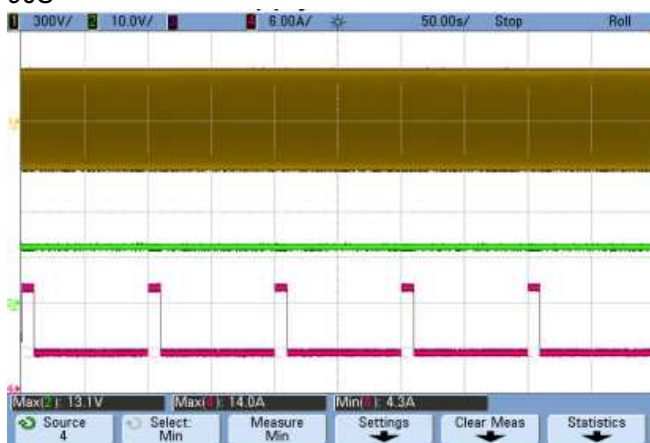

CH1:Vin, CH2:Vout, CH4:Iout
Average Power: 60.064W

4. Applications

4.1 Test Set-Up

The basic test set-up to measure parameters such as efficiency and load regulation is shown in Figure 1. When testing the Cincon's CFM81S series under any transient conditions, please ensure that the transient response of the source is sufficient to power the equipment under test. We can calculate the

- Efficiency
- Load regulation and line regulation.

The value of efficiency is defined as:

Where:

Vo is output voltage

Io is output current

Pin is input power

The value of load regulation is defined as:

Where:

V_{FL} is the output voltage at full load

V_{NL} is the output voltage at 10% load

The value of line regulation is defined as:

$$\text{Line reg.} = \frac{V_{HL} - V_{LL}}{V_{LL}} \times 100\%$$

Where:

V_{HL} is the output voltage of maximum input voltage at full load.

V_{LL} is the output voltage of minimum input voltage at full load.

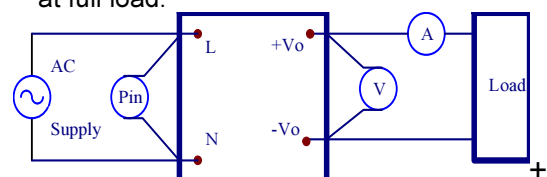

Figure 1. CFM81S Series Test Setup

4.2 Output Ripple and Noise Measurement

The test set-up for noise and ripple measurements is shown in Figure 2 Measured method:

Add a 0.1 uF ceramic capacitor and a 10 uF electrolytic capacitor to output at 20 MHz Band Width.

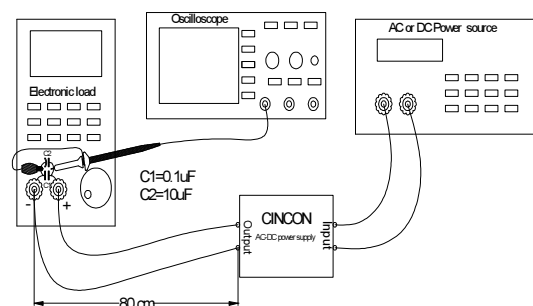

Figure 2. Output Voltage Ripple and Noise Measurement Set-Up



CFM81S Series

Application Note V10

4.3 Installation Instruction

Please use the mounting hold as:
 CFM81S series: 4 holds of $\varphi 3.17$
 And insert the spacer (Max $\varphi 6$) of height over 8mm to lift the unit. The vibration spec. is the value take when the unit is raised by 8mm spacers.

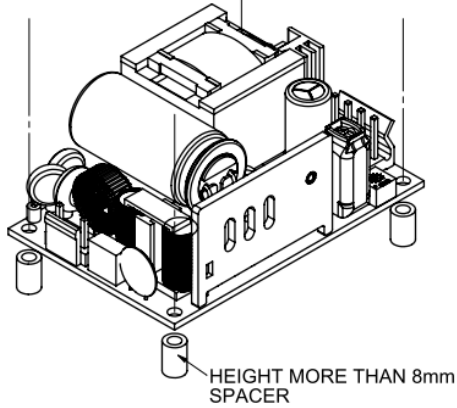

Please reserve 4mm space from the surfaces and the sides of PCB, especially from the solder surface, 8mm space is necessary. If the space is not enough, the specification of insulation and withstand will not be satisfied.

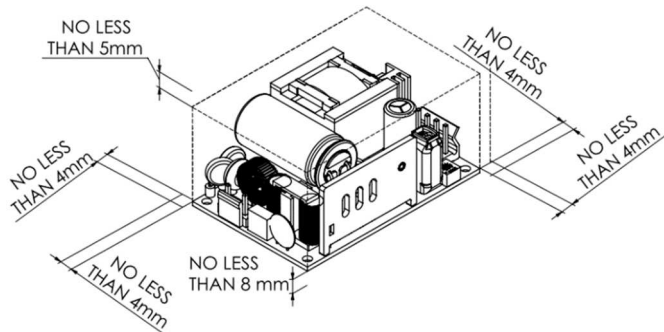

FG should be connected to the earth (ground) terminal of the apparatus. If not, the conducted noise and output noise will increase.

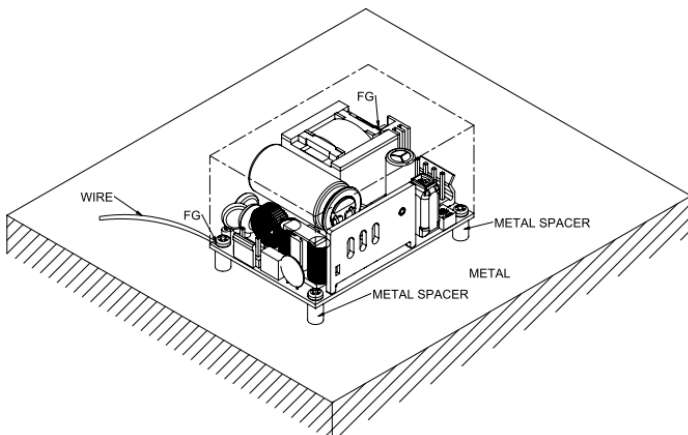

The CFM81SXXX-P mounting holes are 1.5mm. Please allow 4mm side clearance from the components and all side of the PCB. Allow 5mm

clearance above the highest parts on the PCB.

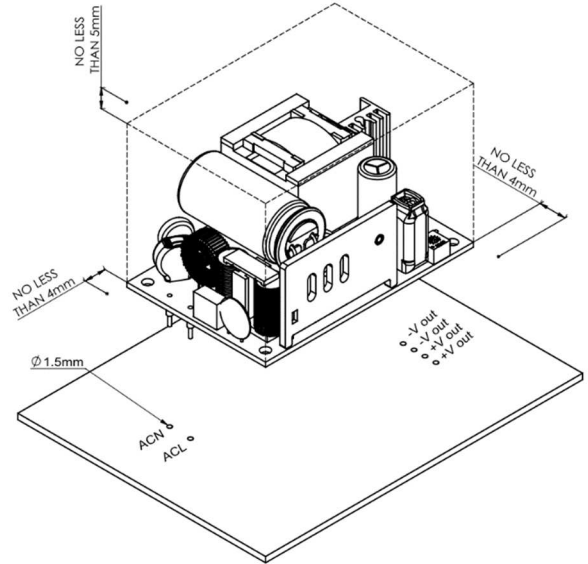

CFM81SXXX-P installation diagram

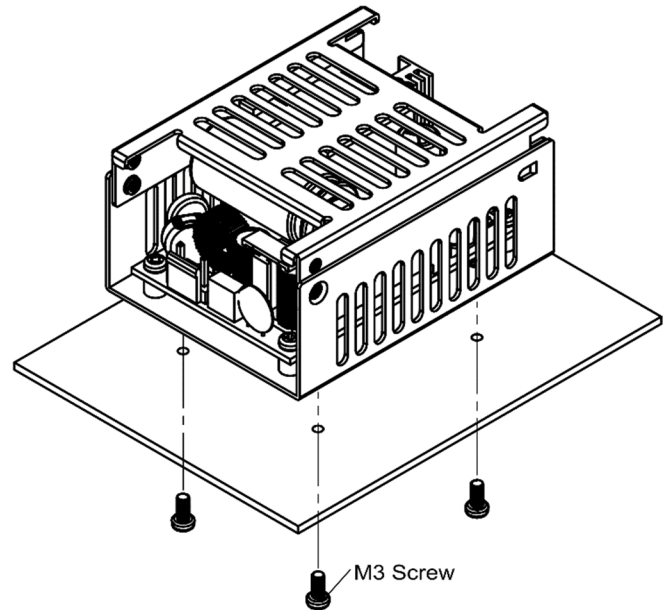

CFM81SXXX-CA installation diagram

Note: M3&M4 screw head and washer diameter shall not exceed 5.5mm



CFM81S Series

Application Note V10

5. Packing Information

The packing information for CFM81SXXX SERIES:

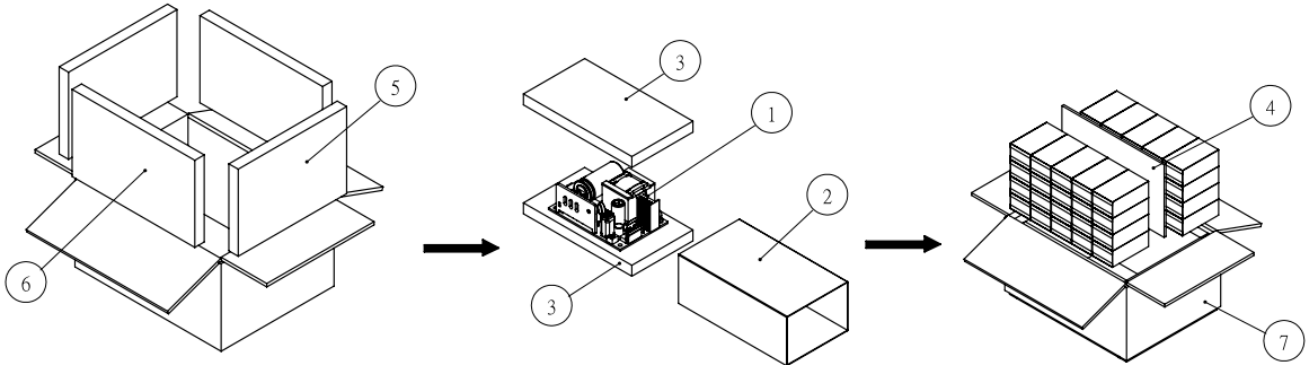

ITEM	PART NO.	NAME	OUTSIDE DIM	PCS
1	-	CFM81SXXX Product	76.2x50.8x34mm	40
2	G64304161	Inner Box	115x65x45 mm	40
3	G64308312	Antistatic Foam	115x65x10 mm	80
4	G64U10075	Partition	326x200x6 mm	1
5	G64301115	Antistatic Foam	288x200x25 mm	2
6	G64301114	Antistatic Foam	326x200x25 mm	2
7	G64114347	No.149 Cardboard Box	388x300x220mm	1

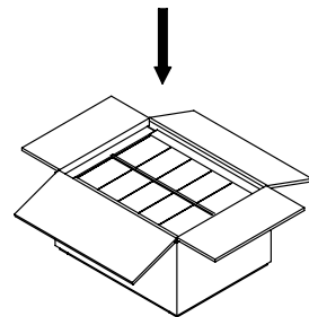

Each Box Packaging 40 PCS Products
Gross weight Ref. 6.4 Kg

CFM81SXXX 40pcs a box, including the total weight of package material about 6.4Kg

The packing information for CFM81SXXX-P SERIES:

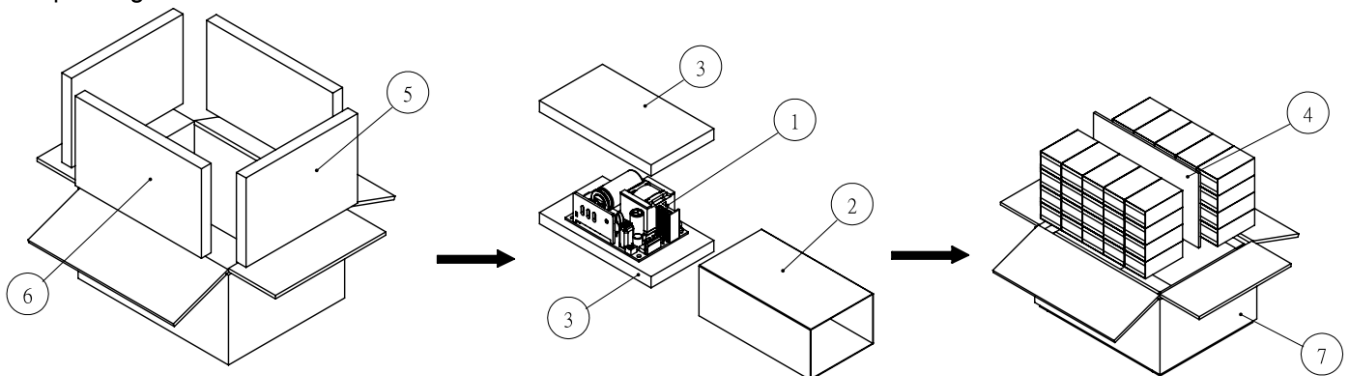

ITEM	PART NO.	NAME	OUTSIDE DIM	PCS
1	-	CFM81SXXX-P Product	76.2x50.8x34mm	40
2	G64304161	Inner Box	115x65x45 mm	40
3	G64308312	Antistatic Foam	115x65x10 mm	80
4	G64U10075	Partition	326x200x6 mm	1
5	G64301115	Antistatic Foam	288x200x25 mm	2
6	G64301114	Antistatic Foam	326x200x25 mm	2
7	G64114347	No.149 Cardboard Box	388x300x220mm	1

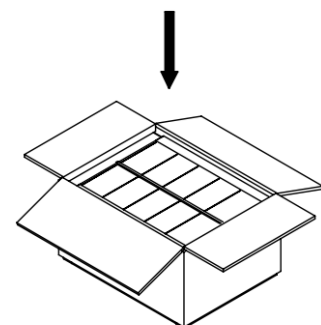

Each Box Packaging 40 PCS Products
Gross weight Ref. 6.4 Kg

CFM81SXXX-P 40 pcs a box, including the total weight of package material about 6.4Kg



CFM81S Series

Application Note V10

The packing information for CFM81SXXX-CA SERIES:

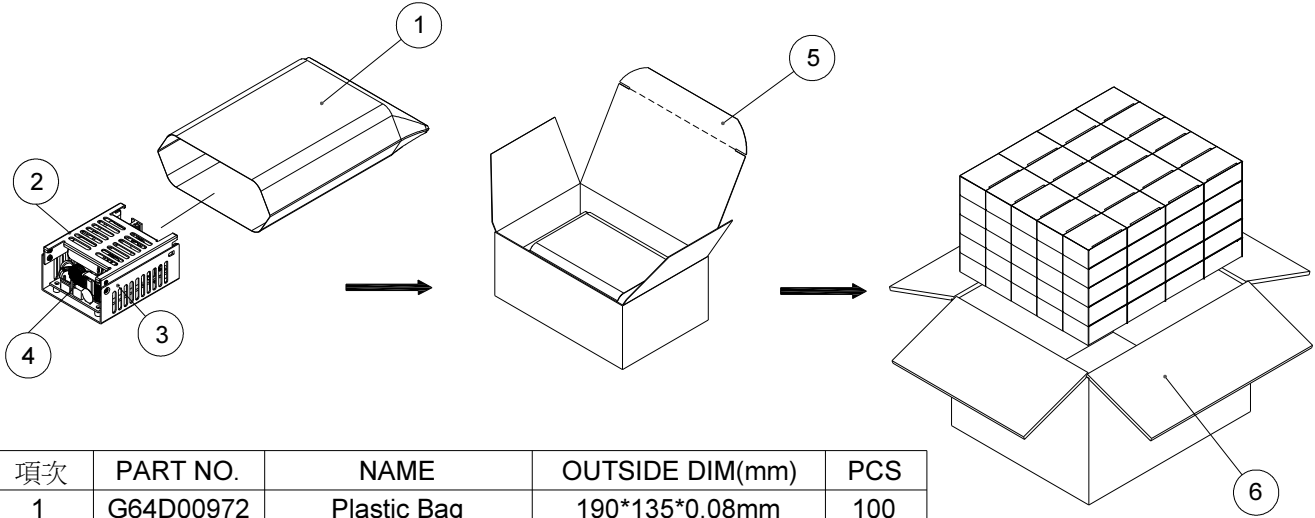

項次	PART NO.	NAME	OUTSIDE DIM(mm)	PCS
1	G64D00972	Plastic Bag	190*135*0.08mm	100
2	G6612090621	CFM81S Metal Case	81.28*60*16mm T=1mm	100
3	G6612100621	CFM81S Metal Base	81.28*62*32mm T=1mm	100
4	-	CFM81SXXX-CA Product	81.28*62*40mm	100
5	G64304172	Inner Box	90*65*40mm	100
6	G64114396	NO.205 Cardboard Box	380*340*220mm	1

Each Box Packaging 100 PCS Products
Gross weight Ref. 17.5 Kg

CFM81SXXX-CA 100 pcs a box, including the total weight of package material about 17.5Kg

CINCON ELECTRONICS CO., LTD.

Headquarters:

14F, No.306, Sec.4, Hsin Yi Rd.
Taipei, Taiwan
Tel: 886-2-27086210
Fax: 886-2-27029852
E-mail: support@cincon.com.tw
Web Site: <http://www.cincon.com>

Factory:

No. 8-1, Fu Kung Rd.
Fu Hsing Industrial Park
Fu Hsing Hsiang,
Chang Hua Hsien, Taiwan
Tel: 886-4-7690261
Fax: 886-4-7698031

Cincon North America:

1655 Mesa Verde Ave. Ste 180
Ventura, CA 93003
Tel: 805-639-3350
Fax: 805-639-4101
E-mail: info@cincon.com