



CQB100W-110SXX Series Application Note V12

ISOLATED DC-DC CONVERTER CQB100W-110SXX SERIES APPLICATION NOTE



Approved By:

Department	Approved By	Checked By	Written By
Research and Development Department	Enoch	Astray	Elsie
		Jacky	
Design Quality Department	Benny	JoJo	



CQB100W-110SXX Series Application Note V12

Contents

1. Introduction	3
2. DC-DC Converter Features.....	3
3. Electrical Block Diagram	3
4. Technical Specifications.....	4
5. Main Features and Functions.....	9
5.1 Operating Temperature Range	9
5.2 Output Voltage Adjustment	9
5.3 Over Current Protection	9
5.4 Output Over Voltage Protection	9
5.5 Remote On/Off.....	9
5.6 UVLO (Under Voltage Lock Out)	9
5.7 Over Temperature Protection.....	10
6. Applications.....	10
6.1 Recommend Layout, PCB Footprint and Soldering Information.....	10
6.2 Connection for standard use	10
6.3 Input Capacitance at the Power Module	11
6.4 Convection Requirements for Cooling	11
6.5 Thermal Considerations.....	11
6.6 Power Derating	12
6.7 Quarter Brick Heat Sinks:.....	14
6.8 Efficiency VS. Load	15
6.9 Test Set-Up	16
6.10 Output Voltage Adjustment	16
6.11 Output Remote Sensing.....	18
6.12 Output Ripple and Noise	18
6.13 Output Capacitance	19
6.14 Remote On/Off circuit.....	19
6.15 Series Operation	19
6.16 Parallel/Redundant Operation.....	20
7. Safety & EMC	21
7.1 Input Fusing and Safety Considerations.....	21
7.2 EMC Considerations	21
7.3 Suggested Configuration for RIA12 Surge Test.....	23
8. Part Number.....	24
9. Mechanical Specifications.....	24
9.1 Mechanical Outline Diagrams	24



CQB100W-110SXX Series Application Note V12

1. Introduction

The CQB100W-110SXX series offers 100 watts of output power with high power density in an industry standard quarter-brick package. The CQB100W-110SXX series has wide (4:1) input voltage ranges of 43-160VDC and provides a precisely regulated output. This series has features such as high efficiency, 3000VDC isolation and a case operating temperature range of -40°C to 105°C . The modules are fully protected against input UVLO (under voltage lock out), output short circuit, output over voltage and over temperature conditions. Furthermore, the standard control functions include remote on/off and output voltage trimming. All models are highly suited to railway, telecommunications, distributed power architectures, battery operated equipment, industrial, and mobile equipment applications.

2. DC-DC Converter Features

- 100W Isolated Output
- Efficiency to 92%
- Fixed Switching Frequency
- 4:1 Input Range
- Regulated Outputs
- Remote On/Off
- Low No Load Power Consumption
- Over Temperature Protection
- Over Voltage/Current Protection
- Continuous Short Circuit Protection
- Quarter Brick Size meet industrial standard
- UL60950-1 2nd (Basic Insulation) Approval (Except 15Vout)
- Meets EN50155 with External Circuits
- Fire & Smoke Meets EN45545-2
- 3000m Operating Altitude
- CB Test Certificate IEC60950-1(Except 15Vout)

3. Electrical Block Diagram

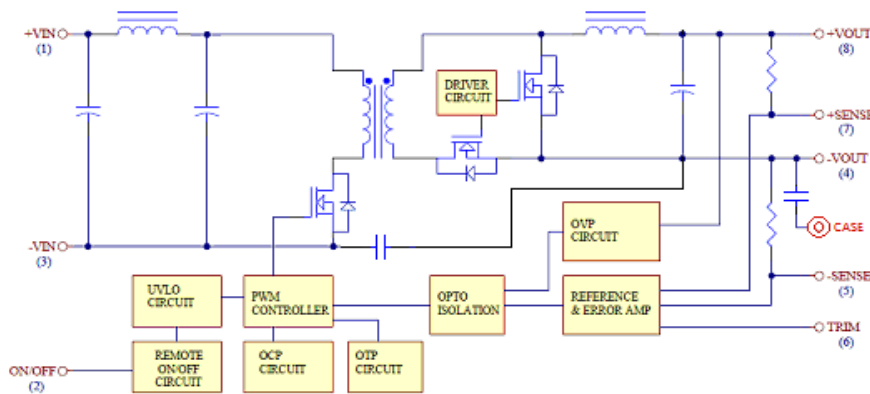

Electrical Block Diagram for 5Vout, 12Vout and 15Vout

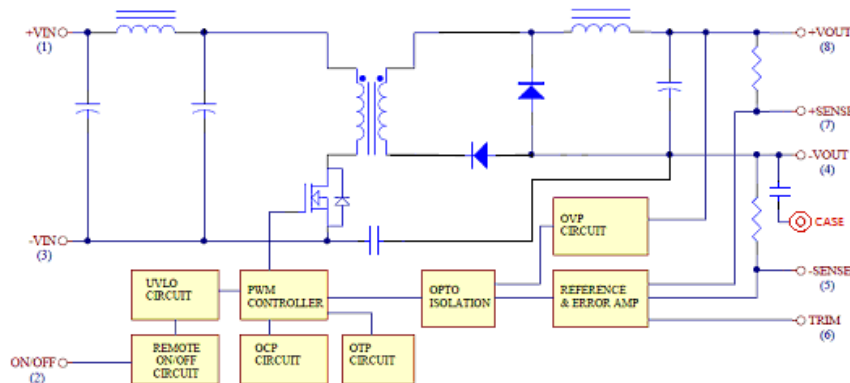

Electrical Block Diagram for other modules



CQB100W-110SXX Series Application Note V12

4. Technical Specifications

(All specifications are typical at nominal input, full load at 25°C unless otherwise noted.)

ABSOLUTE MAXIMUM RATINGS

PARAMETER	NOTES and CONDITIONS	Device	Min.	Typical	Max.	Units
Input Voltage						
Continuous		All	-0.3		160	V _{dc}
Transient	100ms	All			200	V _{dc}
Operating Case Temperature		All	-40		105	°C
Storage Temperature		All	-55		125	°C
Isolation Voltage	1 minute; input/output,	All			3000	V _{dc}
	1 minute; input/case,	All			2250	V _{dc}
	1 minute; output/case	All			500	V _{ac}

INPUT CHARACTERISTICS

PARAMETER	NOTES and CONDITIONS	Device	Min.	Typical	Max.	Units
Operating Input Voltage		All	43	110	160	V _{dc}
Input Under Voltage Lockout						
Turn-On Voltage Threshold		All	40.5	41.5	42.5	V _{dc}
Turn-Off Voltage Threshold		All	37	38	39	V _{dc}
Lockout Hysteresis Voltage		All		3.5		V _{dc}
Maximum Input Current	100% Load, V _{in} =110V for All	All		1.5		A
No-Load Input Current		110S05		10		mA
		110S12		10		
		110S15		10		
		110S24		10		
		110S28		10		
		110S48		10		
Input Filter	Pi filter.	All				
Inrush Current (I ² t)	As per ETS300 132-2.	All			0.1	A ² s
Input Reflected Ripple Current	P-P thru 12uH inductor, 5Hz to 20MHz, See 6.3	All		30		mA

OUTPUT CHARACTERISTICS

PARAMETER	NOTES and CONDITIONS	Device	Min.	Typical	Max.	Units
Output Voltage Set Point	V _{in} =Nominal V _{in} , I _o = I _{o_max} , T _c =25°C	Vo=5.0V	4.95	5	5.05	V _{dc}
		Vo=12V	11.88	12	12.12	
		Vo=15V	14.85	15	15.15	
		Vo=24V	23.76	24	24.24	
		Vo=28V	27.72	28	28.28	
		Vo=48V	47.52	48	48.48	



CQB100W-110SXX Series

Application Note V12

PARAMETER	NOTES and CONDITIONS	Device	Min.	Typical	Max.	Units
Output Voltage Regulation						
Load Regulation	$I_o = I_{o_min}$ to I_{o_max}	All			±0.2	%
Line Regulation	V_{in} =low line to high line	All			±0.2	%
Temperature Coefficient	$T_c = -40^\circ\text{C}$ to 105°C	All			±0.02	%/°C
Output Voltage Ripple and Noise (5Hz to 20MHz bandwidth)						
Peak-to-Peak	Full load, 10uF tantalum and 1uF ceramic capacitors (for $V_o=48\text{V}$: Full Load 10uF aluminum and 1uF ceramic capacitors). See 6.12	$V_o = 5.0\text{V}$			100	mV
		$V_o = 12\text{V}$			150	
		$V_o = 15\text{V}$			150	
		$V_o = 24\text{V}$			280	
		$V_o = 28\text{V}$			280	
		$V_o = 48\text{V}$			480	
RMS.		$V_o = 5.0\text{V}$			40	mV
		$V_o = 12\text{V}$			60	
		$V_o = 15\text{V}$			60	
		$V_o = 24\text{V}$			100	
		$V_o = 28\text{V}$			100	
		$V_o = 48\text{V}$			200	
Operating Output Current Range		$V_o = 5.0\text{V}$	0		20	A
		$V_o = 12\text{V}$	0		8.4	
		$V_o = 15\text{V}$	0		6.7	
		$V_o = 24\text{V}$	0		4.2	
		$V_o = 28\text{V}$	0		3.6	
		$V_o = 48\text{V}$	0		2.1	
Output DC Current Limit Inception	Hiccup Mode. Auto Recovery. See 5.3	All	110	125	160	%
Maximum Output Capacitance	Full load (resistive)	110S05	0		20000	uF
		110S12	0		8400	
		110S15	0		6700	
		110S24	0		4200	
		110S28	0		3600	
		110S48	0		1000	
Output Voltage Trim Range	P_{out} =max rated power, See 6.10	15Vout	-20		+10	%
		Others	-10		+10	
Output Over Voltage Protection	Limited Voltage, See 5.4	All	115	125	140	%

DYNAMIC CHARACTERISTICS

PARAMETER	NOTES and CONDITIONS	Device	Min.	Typical	Max.	Units
Output Voltage Current Transient						
Error Band	75% to 100% of I_{o_max} step load change $d_i/d_t = 0.1\text{A}/\mu\text{s}$ (within 1% V_{out} nominal)	All			±5	%
Recovery Time		All			250	us



CQB100W-110SXX Series

Application Note V12

PARAMETER	NOTES and CONDITIONS	Device	Min.	Typical	Max.	Units
Turn-On Delay and Rise Time	Full load (Constant resistive load)					
Turn-On Delay Time, From On/Off Control	$V_{on/off}$ to $10\%V_{o_set}$	All		30		ms
Turn-On Delay Time, From Input	V_{in_min} to $10\%V_{o_set}$	All		30		ms
Output Voltage Rise Time	$10\%V_{o_set}$ to $90\%V_{o_set}$	All		30		ms

EFFICIENCY

PARAMETER	NOTES and CONDITIONS	Device	Min.	Typical	Max.	Units
100% Load	$V_{in}=110V$ See 6.8	110S05		91		%
		110S12		92		
		110S15		91		
		110S24		89		
		110S28		88.5		
		110S48		90		

ISOLATION CHARACTERISTICS

PARAMETER	NOTES and CONDITIONS	Device	Min.	Typical	Max.	Units	
Isolation Voltage	1 minute; input/output	All			3000	V_{dc}	
	1 minute; input/case,	All			2250	V_{dc}	
	1 minute; output/case	All			500	V_{ac}	
Isolation Resistance	Input / Output	All	100			$M\Omega$	
Isolation Capacitance	Input / Output	All		1500		pF	
	Input/Case	All		NC			
	Output/Case	110S05			470		
		110S12			10000		
		110S15			10000		
		110S24			3000		
110S28			3000				
110S48			4700				

FEATURE CHARACTERISTICS

PARAMETER	NOTES and CONDITIONS	Device	Min.	Typical	Max.	Units
Switching Frequency	Pulse wide modulation (PWM), Fixed	All	270	300	330	KHz
On/Off Control, Positive Remote On/Off Logic, Refer to $-V_{in}$ Pin.						
Logic Low (Module Off)	$V_{on/off}$ at $I_{on/off}=1.0mA$	All	0		1.2	V
Logic High (Module On)	$V_{on/off}$ at $I_{on/off}=0.0uA$	All	3.5 or Open Circuit		160	V



CQB100W-110SXX Series

Application Note V12

PARAMETER	NOTES and CONDITIONS	Device	Min.	Typical	Max.	Units
On/Off Control, Negative Remote On/Off Logic, Refer to -Vin Pin						
Logic High (Module Off)	$V_{on/off}$ at $I_{on/off}=0.0\mu A$	All	3.5 or Open Circuit		160	V
Logic Low (Module On)	$V_{on/off}$ at $I_{on/off}=1.0mA$	All	0		1.2	V
On/Off Current (for both remote on/off logic)	$I_{on/off}$ at $V_{on/off}=0.0V$	All		0.3	1	mA
Leakage Current (for both remote on/off logic)	Logic High, $V_{on/off}=15V$	All			30	μA
Off Converter Input Current	Shutdown input idle current	All		5	10	mA
Output Voltage Trim Range	$P_{out}=\text{max rated power}$	All	-10		+10	%
Output Over Voltage Protection		All	115	125	140	%
Over Temperature Shutdown	Aluminum base plate temperature	All		110		$^{\circ}C$
Over Temperature Recovery				100		$^{\circ}C$

GENERAL SPECIFICATIONS

PARAMETER	NOTES and CONDITIONS	Device	Min.	Typical	Max.	Units
MTBF	$I_o=100\%$ of I_{o_max} ; MIL-HDBK - 217F_Notice 1, GB, $25^{\circ}C$	110S05 110S12 Others		720 720 840		K hours
Weight		All		68		grams
Case Material	Plastic, DAP					
Base plate Material	Aluminum					
Potting Material	UL 94V-0					
Pin Material	Base: Copper Plating: Nickel with Matte Tin					
Shock/Vibration	MIL-STD-810F / EN61373					
Humidity	95% RH max. Non Condensing					
Altitude	3000m Operating Altitude, 12000m Transport Altitude					
Thermal Shock	MIL-STD-810F					
EMI	Meets EN55011, EN55022 & EN50155 with external input filter, see 7.2 EN55032					Class A
ESD	EN61000-4-2	Level 3: Air $\pm 8kV$, Contact $\pm 6kV$				Perf. Criteria A
Radiated immunity	EN61000-4-3	Level 3: 80~1000MHz, 20V/m				Perf. Criteria A
Fast Transient	EN61000-4-4	Level 3: On power input port, $\pm 2kV$, external input capacitor required, see 7.1				Perf. Criteria A
Surge	EN61000-4-5	Level 4: Line to earth, $\pm 4kV$, Line to line, $\pm 2kV$				Perf. Criteria A
Conducted immunity	EN61000-4-6	Level 3: 0.15~80MHz, 10V				Perf. Criteria A
Interruptions of Voltage Supply	EN50155	Class S2: 10ms interruptions				Perf. Criteria B
Supply Change Over	EN50155	Class C2: During a supply break of 30 ms				Perf. Criteria B



CQB100W-110SXX Series

Application Note V12

Immunity to Environmental Conditions.

Phenomenon	EN50155; 2005 Reference Clause(s)	Reference Standard	Test Conditions	Result
Cooling Test	EN 50155 section 12.2.3 Column 4, Class TX	EN 60068-2-1	Temperature: -40°C Dwell time: 2 hrs/ cycle	Pass
Dry Heat Test	EN 50155 section 12.2.4 Column 4, Class TX	EN 60068-2-2	Temperature: 85°C Duration: 6 hrs/ 10min	Pass
Damp Heat test, Cyclic	EN 50155 section 12.2.5	EN 60068-2-30	Temperature: 25°C - 55°C Humidity: 90% RH Duration: 48 hrs	Pass
Vibration Test	EN 50155 section 12.2.11	EN 61373	Temperature: 25°C +/- 10°C Humidity: 50% +/-25% RH Duration: 10 mins	Pass
Increased Vibration Test	EN 50155 section 12.2.11	EN 61373	Temperature: 25°C +/-10°C Humidity: 50% +/-25% RH Duration: 5 hrs	Pass
Shock Test	EN 50155 section 12.2.11	EN 61373	Temperature: 25°C +/-10°C Humidity: 50% +/-25% RH Duration: 30mS x18	Pass
Low Temperature Storage Test	EN 50155 section 12.2.3 Column 4, Class TX	EN 60068-2-1	Temperature: -40°C Dwell time: 16 hrs	Pass

EN45545-2 Fire & Smoke Test Conditions.

Item		Standard	Hazard Level
R22	Oxygen Index Test	EN 45545-2: 2013 EN ISO 4589-2: 2006	HL1, HL2, HL3
	Smoke Density Test	EN 45545-2: 2013 EN ISO 5659-2: 2013	HL1, HL2
	Smoke Toxicity Test	EN 45545-2: 2013 NF X70-100: 2006	HL1, HL2, HL3
R23	Oxygen Index Test	EN 45545-2: 2013 EN ISO 4589-2: 2006	HL1, HL2, HL3
	Smoke Density Test	EN 45545-2: 2013 EN ISO 5659-2: 2013	HL1, HL2, HL3
	Smoke Toxicity Test	EN 45545-2: 2013 NF X70-100: 2006	HL1, HL2, HL3
R24	Oxygen Index Test	EN45545-2: 2013 EN ISO 4589-2	HL1, HL2, HL3
R26	Vertical Flame Test	EN 45545-2: 2013 EN 60695-11-10: 2013	HL1, HL2, HL3



CQB100W-110SXX Series Application Note V12

5. Main Features and Functions

5.1 Operating Temperature Range

The CQB100W-110SXX series converters can be operated within a wide case temperature range of -40°C to 105°C . Consideration must be given to the derating curves when ascertaining maximum power that can be drawn from the converter. The maximum power drawn from open quarter brick models is influenced by usual factors, such as:

- Input voltage range
- Output load current
- Forced air or natural convection
- Heat sink optional

5.2 Output Voltage Adjustment

Section 6.10 describes in detail how to trim the output voltage with respect to its set point. The output voltage on all models is adjustable within the range of $+10\%$ to -10% .

5.3 Over Current Protection

All models have internal over current and continuous short circuit protection. The unit operates normally once the fault condition is removed. At the point of current limit inception, the converter will go into hiccup mode protection.

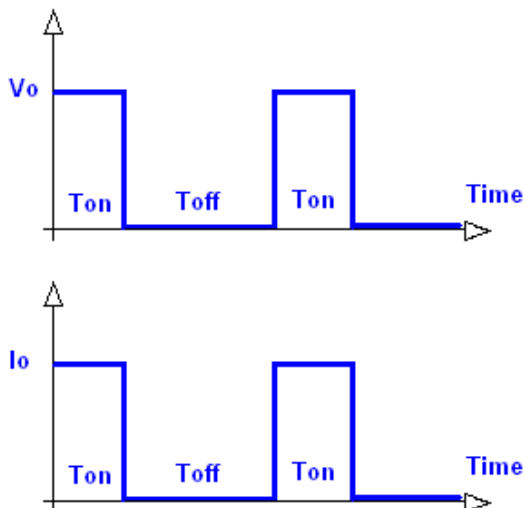

5.4 Output Over Voltage Protection

The output over voltage protection consists of circuitry that internally limits the output voltage. If more accurate output over voltage protection is required then an external circuit can be used via the remote on/off pin.

Note: Please note that device inside the power supply might fail when voltage more than rate output voltage is applied to output pin. This could happen when the customer tests the over voltage protection of unit.

5.5 Remote On/Off

The CQB100W-110SXX series allows the user to switch the module on and off electronically with the remote On/Off feature. All models are available in “positive logic” and “negative logic” (optional) versions. The converter turns on if the remote On/Off pin is high ($>3.5\text{Vdc}$ to 160Vdc or open circuit). Setting the pin low (0 to $<1.2\text{Vdc}$) will turn the converter off. The signal level of the remote On/Off input is defined with respect to ground. If not using the remote On/Off pin, leave the pin open (converter will be on). Models with part number suffix “N” are the “negative logic” remote On/Off version. The unit turns off if the remote On/Off pin is high ($>3.5\text{Vdc}$ to 160Vdc or open circuit). The converter turns on if the On/Off pin input is low (0 to $<1.2\text{Vdc}$). Note that the converter is off by default. **See 6.14**

Logic State (Pin 2)	Negative Logic	Positive Logic
Logic Low – Switch Closed	Module on	Module off
Logic High – Switch Open	Module off	Module on

5.6 UVLO (Under Voltage Lock Out)

Input under voltage lockout is standard on the CQB100W-110SXX unit. The unit will shut down when the input voltage drops below a threshold, and the unit will operate when the input voltage goes above the upper threshold.

**CQB100W-110SXX
Iin Vs Vin**

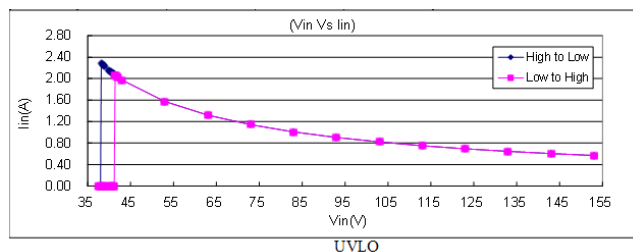



CQB100W-110SXX Series Application Note V12

5.7 Over Temperature Protection

These modules have an over temperature protection circuit to safeguard against thermal damage. Shutdown occurs with the maximum case reference temperature is exceeded. The module will restart when the case temperature falls below over temperature recovery threshold. Please measure case temperature of the center part of aluminum base plate.

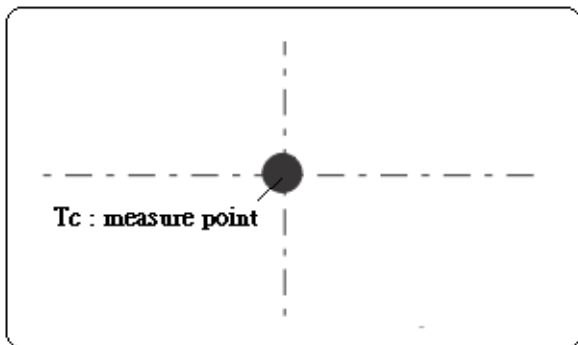
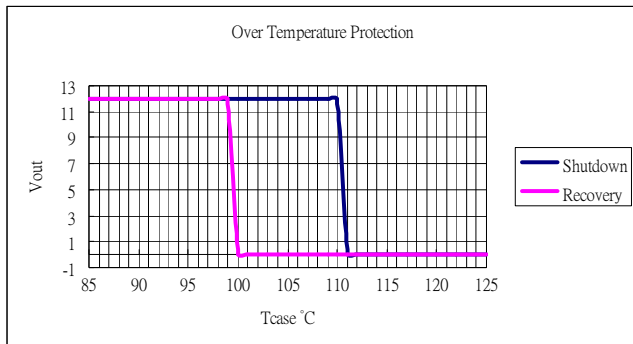

Lead Free Wave Soldering Profile

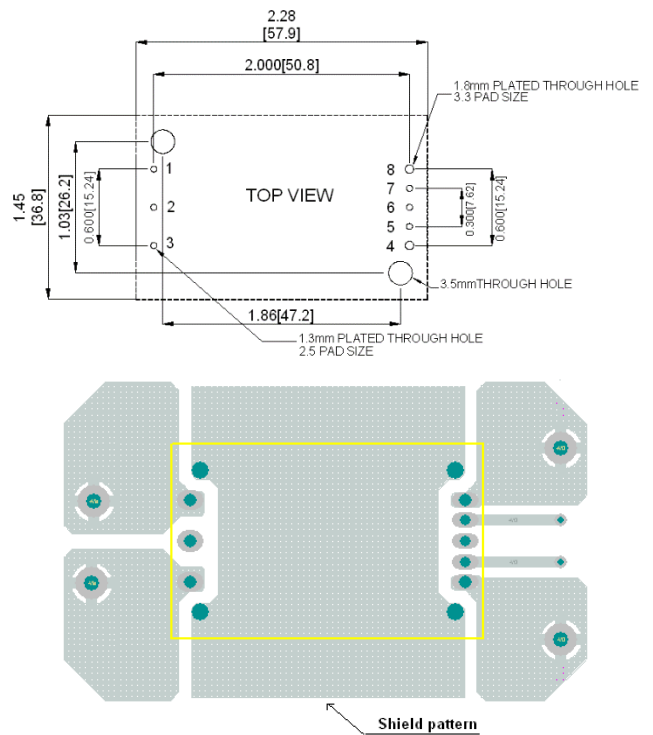
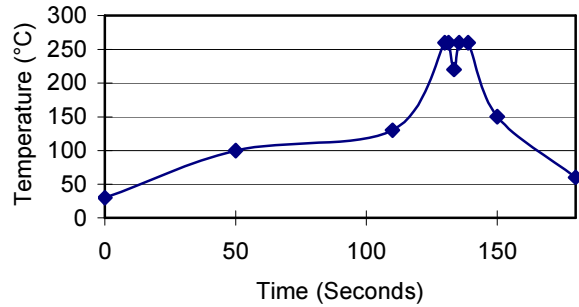

6. Applications

6.1 Recommend Layout, PCB Footprint and Soldering Information

The system designer or end user must ensure that metal and other components in the vicinity of the converter meet the spacing requirements for which the system is approved. Low resistance and inductance PCB layout traces are the norm and should be used where possible. Due consideration must also be given to proper low impedance tracks between power module, input and output grounds. The recommended soldering profile and PCB layout are shown below.

6.2 Connection for standard use

The connection for standard use is shown below. An external input capacitor (C1) 220uF for all models is recommended to reduce input ripple voltage. External output capacitors (C2, C3) are recommended to reduce output ripple and noise, 10uF aluminum and 1uF ceramic capacitors for 48Vout, and 10uF tantalum and 1uF ceramic capacitors for other models.

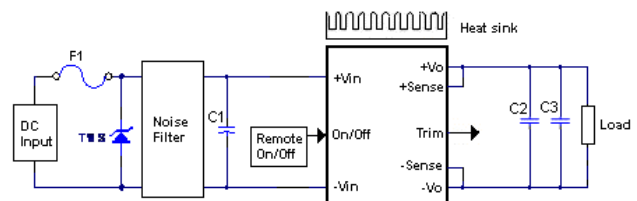



CQB100W-110SXX Series

Application Note V12

Symbol	Component	Reference
F1, TVS	Input fuse, TVS	Section 7.1
C1	External capacitor on input side	Note
C2, C3	External capacitor on the output side	Section 6.12/6.13
Noise Filter	External input noise filter	Section 7.2
Remote On/Off	External Remote On/Off control	Section 6.14
Trim	External output voltage adjustment	Section 6.10
Heat sink	External heat sink	Section 6.4/6.5/6.6/6.7
+Sense/-Sense	--	Section 6.11

exceed 105°C as measured at the center of the top of the case (thus verifying proper cooling).

6.5 Thermal Considerations

The power module operates in a variety of thermal environments; however, sufficient cooling should be provided to help ensure reliable operation of the unit. Heat is removed by conduction, convection, and radiation to the surrounding environment. The example is presented in **section 6.6**. The power output of the module should not be allowed to exceed rated power ($V_{o_set} \times I_{o_max}$).

Note:

If the impedance of input line is high, C1 capacitance must be more than above. Use more than two recommended capacitor above in parallel when ambient temperature becomes lower than -20 °C.

6.3 Input Capacitance at the Power Module

The converters must be connected to low AC source impedance. To avoid problems with loop stability source inductance should be low. Also, the input capacitors (Cin) should be placed close to the converter input pins to decouple distribution inductance. However, the external input capacitors are chosen for suitable ripple handling capability. Low ESR capacitors are good choice. Circuit as shown as below represents typical measurement methods for reflected ripple current. C1 and L1 simulate a typical DC source impedance. The input reflected-ripple current is measured by current probe to oscilloscope with a simulated source Inductance (L1).

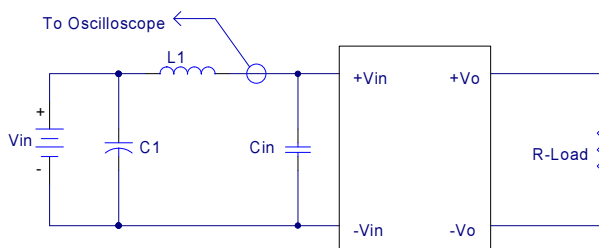

L1: 12uH

C1: 220uF ESR<0.075ohm @100KHz

Cin: 220uF ESR<0.07ohm @100KHz

6.4 Convection Requirements for Cooling

To predict the approximate cooling needed for the quarter brick module, refer to the power derating curves in **section 6.6**. These derating curves are approximations of the ambient temperatures and airflows required to keep the power module temperature below its maximum rating. Once the module is assembled in the actual system, the module's temperature should be monitored to ensure it does not



CQB100W-110SXX Series Application Note V12

6.6 Power Derating

The operating case temperature range of CQB100W-110SXX series is -40°C to $+105^{\circ}\text{C}$. When operating the CQB100W-110SXX series, proper derating or cooling is needed. The maximum case temperature under any operating condition should not exceed 105°C .

The following curve is the de-rating curve of CQB100W-110SXX series without heat sink.

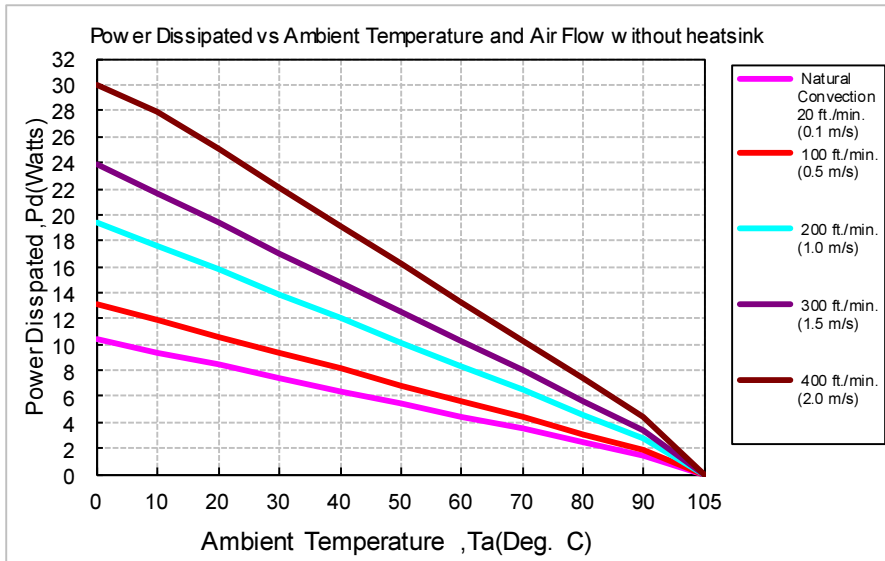

AIR FLOW RATE	TYPICAL R_{ca}
Natural Convection 20ft./min. (0.1m/s)	10.1 $^{\circ}\text{C}/\text{W}$
100 ft./min. (0.5m/s)	8.0 $^{\circ}\text{C}/\text{W}$
200 ft./min. (1.0m/s)	5.4 $^{\circ}\text{C}/\text{W}$
300 ft./min. (1.5m/s)	4.4 $^{\circ}\text{C}/\text{W}$
400 ft./min. (2.0m/s)	3.4 $^{\circ}\text{C}/\text{W}$

Example:

What is the minimum airflow necessary for a CQB100W-110S12 operating at nominal line voltage, an output current of 8.4A, and a maximum ambient temperature of 50°C ?

Solution:

Given:

$$V_{in}=110V_{dc}, V_o=12V_{dc}, I_o=8.4A$$

Determine Power dissipation (P_d):

$$P_d = P_i - P_o = P_o(1-\eta)/\eta$$

$$P_d = 12V \times 8.4A \times (1-0.92)/0.92 = 8.77\text{Watts}$$

Determine airflow:

$$\text{Given: } P_d = 8.77\text{W and } T_a = 50^{\circ}\text{C}$$

Check Power Derating curve:

$$\text{Minimum airflow} = 200 \text{ ft./min.}$$

Verify:

Maximum temperature rise is

$$\Delta T = P_d \times R_{ca} = 8.77\text{W} \times 5.4 = 47.36^{\circ}\text{C}$$

Maximum case temperature is

$$T_c = T_a + \Delta T = 97.36^{\circ}\text{C} < 105^{\circ}\text{C}$$

Where:

The R_{ca} is thermal resistance from case to ambient environment.

T_a is ambient temperature and T_c is case temperature.



CQB100W-110SXX Series Application Note V12

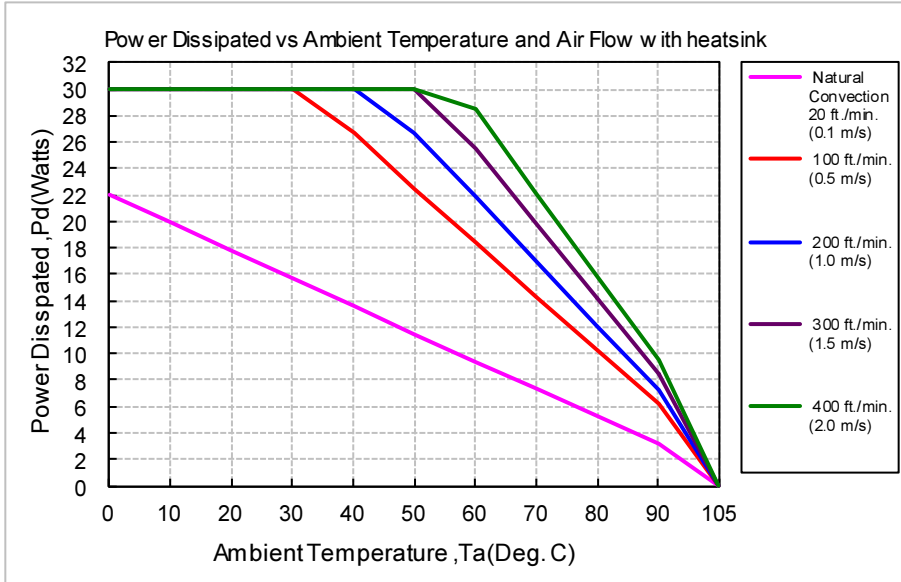

AIR FLOW RATE	TYPICAL R_{ca}
Natural Convection	
20ft./min. (0.1m/s)	4.78 °C/W
100 ft./min. (0.5m/s)	2.44 °C/W
200 ft./min. (1.0m/s)	2.06 °C/W
300 ft./min. (1.5m/s)	1.76 °C/W
400 ft./min. (2.0m/s)	1.58 °C/W

Example with heat sink QBT210 (M-C421):

What is the minimum airflow necessary for a CQB100W-110S24 operating at nominal line voltage, an output current of 4.2A, and a maximum ambient temperature of 60°C?

Solution:

Given:

$$V_{in}=110V_{dc}, V_o=24V_{dc}, I_o=4.2A$$

Determine Power dissipation (P_d):

$$P_d=P_i-P_o=P_o(1-\eta)/\eta$$

$$P_d=24.0 \times 4.2 \times (1-0.89)/0.89=12.46Watts$$

Determine airflow:

$$\text{Given: } P_d=12.46W \text{ and } T_a=60^\circ C$$

Check above Power de-rating curve:

$$\text{Minimum airflow}= 100 \text{ ft./min}$$

Verify:

$$\text{Maximum temperature rise is } \Delta T = P_d \times R_{ca}=12.46 \times 2.44=30.34^\circ C$$

$$\text{Maximum case temperature is } T_c=T_a+\Delta T=90.34^\circ C < 105^\circ C$$

Where:

The R_{ca} is thermal resistance from case to ambient environment.

T_a is ambient temperature and T_c is case temperature.



CQB100W-110SXX Series Application Note V12

6.7 Quarter Brick Heat Sinks:

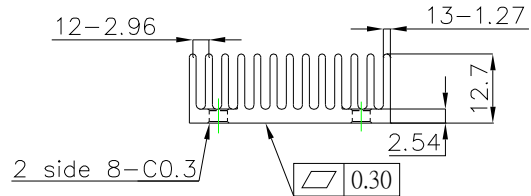
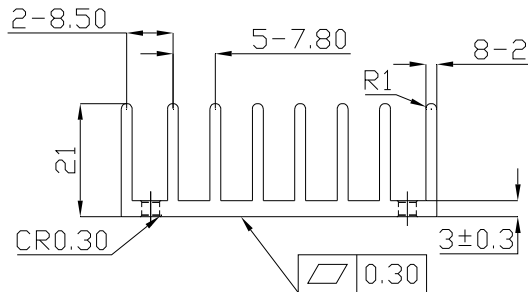
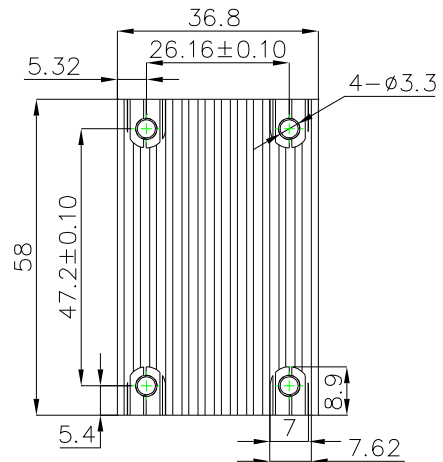
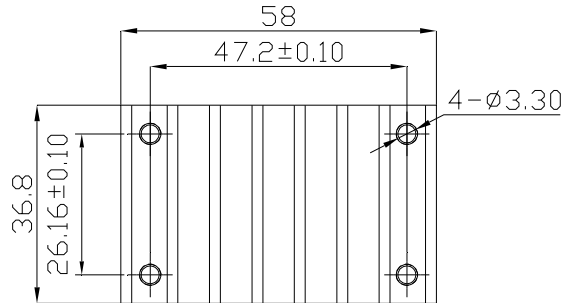

All Dimensions in mm

QBT210 (M-C421) G6620510201 Transverse Heat Sink

- Rca: 4.78°C/W (typ.), At natural convection
- 2.44°C/W (typ.), At 100LFM
- 2.06°C/W (typ.), At 200LFM
- 1.76°C/W (typ.), At 300LFM
- 1.58°C/W (typ.), At 400LFM

QBL127 (M-C448) G6620570202 Longitudinal Heat Sink

- Rca: 5.61°C/W (typ.), At natural convection
- 4.01°C/W (typ.), At 100LFM
- 3.39°C/W (typ.), At 200LFM
- 2.86°C/W (typ.), At 300LFM
- 2.49°C/W (typ.), At 400LFM

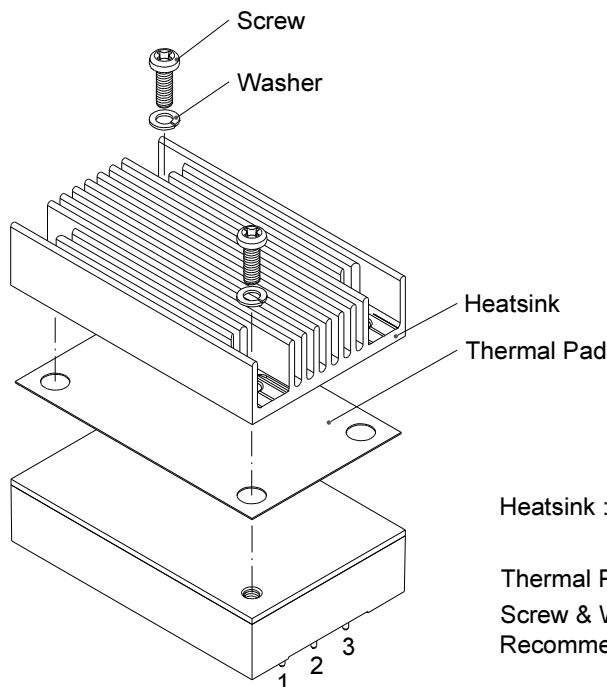

Heatsink : QBL127 (M-C448)
QBT210 (M-C421)

Thermal Pad PQ01: SZ35.8x56.9x0.25mm
Screw & Washer K308W: M3x8L & WS3.2N
Recommended torque 3 Kgf-cm



CQB100W-110SXX Series Application Note V12

6.8 Efficiency VS. Load

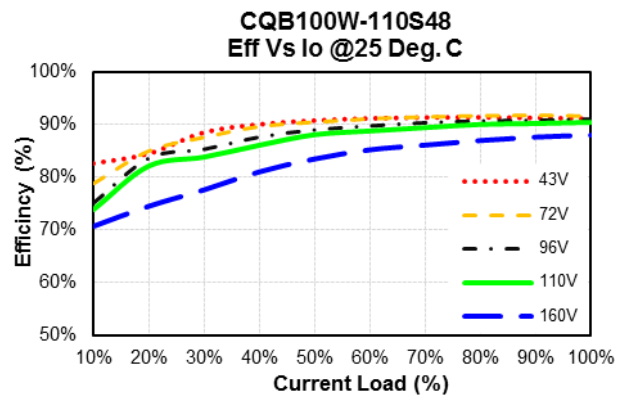
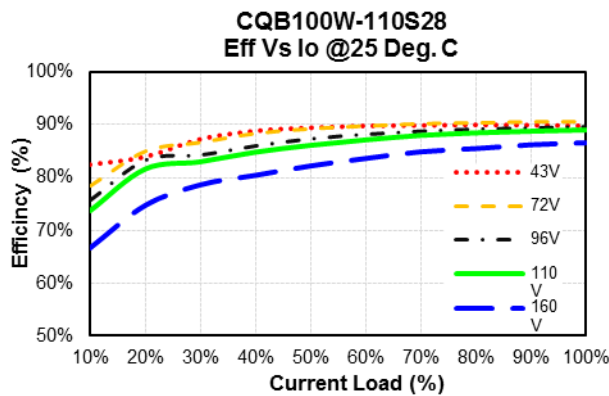
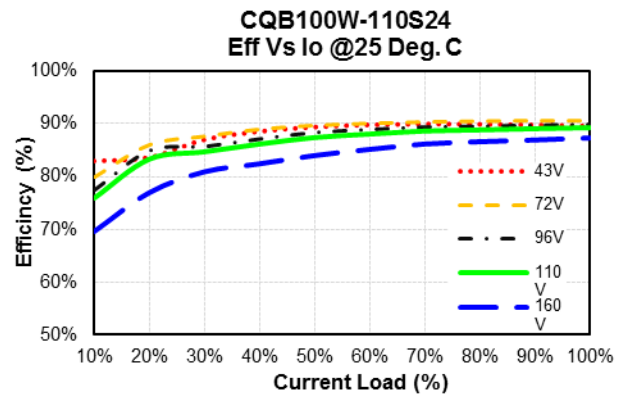
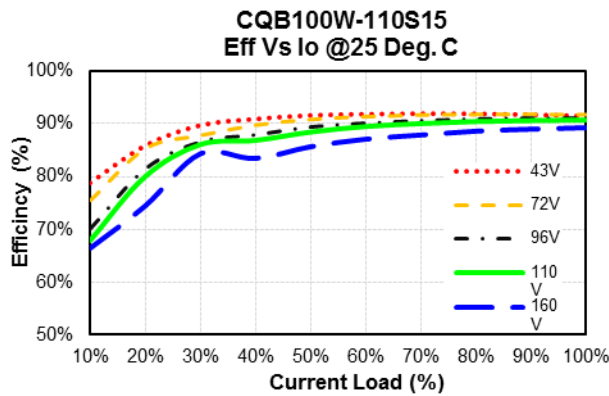
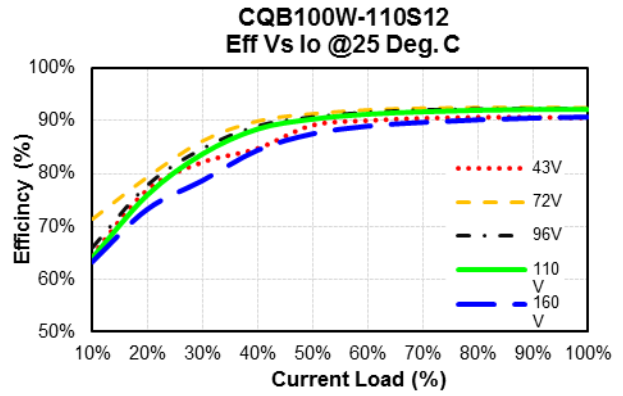
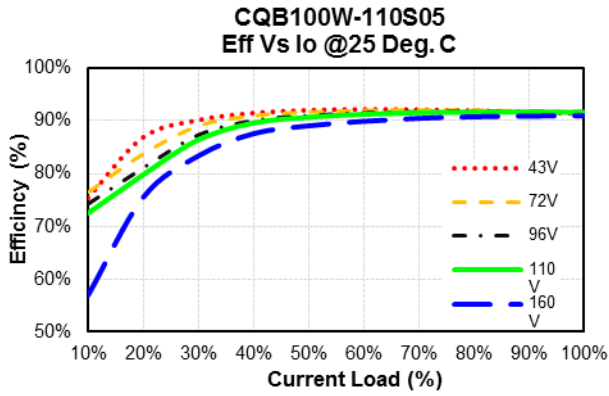



CQB100W-110SXX Series Application Note V12

6.9 Test Set-Up

The basic test set-up to measure parameters such as efficiency and load regulation is shown below. When testing the modules under any transient conditions please ensure that the transient response of the source is sufficient to power the equipment under test. We can calculate:

- Efficiency
- Load regulation and line regulation.

The value of efficiency is defined as:

$$\eta = \frac{V_o \times I_o}{V_{in} \times I_{in}} \times 100\%$$

Where:

- V_o is output voltage,
- I_o is output current,
- V_{in} is input voltage,
- I_{in} is input current.

The value of load regulation is defined as:

$$Load.reg = \frac{V_{FL} - V_{NL}}{V_{NL}} \times 100\%$$

Where:

- V_{FL} is the output voltage at full load.
- V_{NL} is the output voltage at no load.

The value of line regulation is defined as:

$$Line.reg = \frac{V_{HL} - V_{LL}}{V_{LL}} \times 100\%$$

Where: V_{HL} is the output voltage of maximum input voltage at full load. V_{LL} is the output voltage of minimum input voltage at full load.

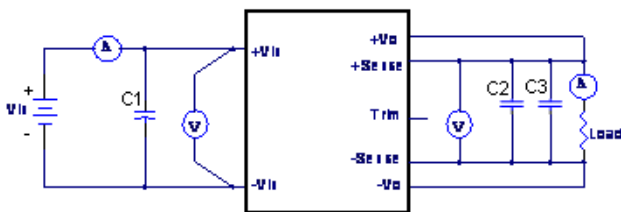

CQB100W-110SXX Series Test Setup

- C1: 220uF/200V ESR<0.035Ω
- C2: 1uF/1210 ceramic capacitor
- C3: 10uF aluminum capacitor for 48Vout.
10uF tantalum capacitor for others.

6.10 Output Voltage Adjustment

Output may be externally trimmed ($\pm 10\%$, except 15Vout is +10%, -20%) with a fixed resistor or an external trim pot as shown (optional). Model specific formulas for calculating trim resistors are available upon request as a separate document.

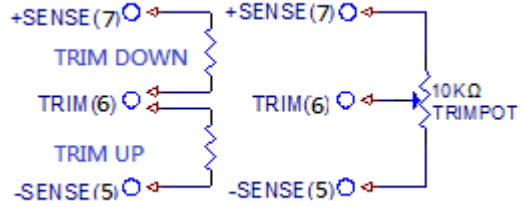

In order to trim the voltage up or down, one needs to connect the trim resistor either between the trim pin and -Sense for trim-up or between trim pin and +Sense for trim-down. The output voltage trim range is $\pm 10\%$. This is shown:

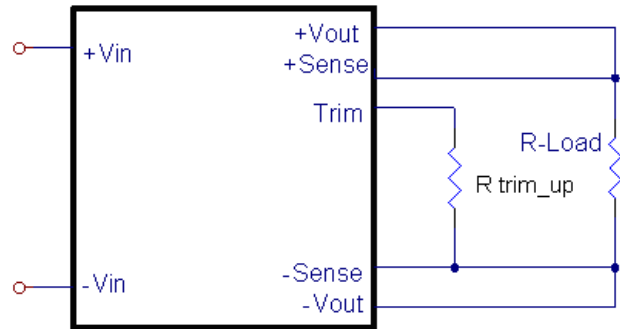

Trim-up Voltage Setup

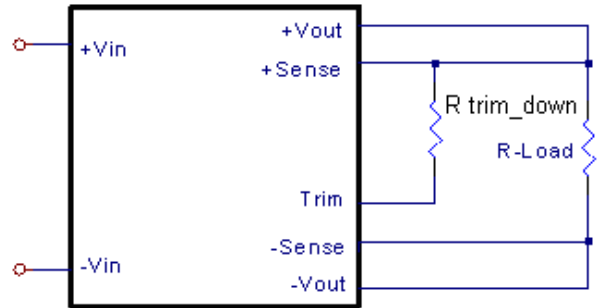

Trim-down Voltage Setup

V _{out} (V)	R1 (KΩ)	R2 (KΩ)	R3 (KΩ)	V _r (V)	V _f (V)
5V	2.32	3.3	0	2.5	0
12V	9.1	51	5.1	2.5	0.46
15V	12	36	8.25	2.5	0.46
24V	20	100	7.5	2.5	0.46
28V	23.7	150	6.2	2.5	0.46
48V	36	270	5.1	2.5	0.46

Trim Resistor Values

The value of R_{trim_up} defined as:

For $V_o=5V$ R_{trim_up} decision:

$$R_{trim_up} = \frac{R_1 V_r}{V_o - V_{o_nom}} - R_2 \quad (\text{K}\Omega)$$



CQB100W-110SXX Series

Application Note V12

For others Rtrim_up decision:

$$R_{trim_up} = \left(\frac{R_1(V_r - V_f(\frac{R_2}{R_2 + R_3}))}{V_o - V_{o_nom}} \right) - \frac{R_2 R_3}{R_2 + R_3} \text{ (K}\Omega\text{)}$$

Where:

Rtrim_up is the external resistor in KΩ.

V_{o_nom} is the nominal output voltage.

V_o is the desired output voltage.

R₁, R₂, R₃ and V_r are internal components.

For example, to trim-up the output voltage of 12V module (CQB100W-110S12) by 5% to 12.6V, Rtrim_up is calculated as follows:

$$V_o - V_{o_nom} = 12.6 - 12 = 0.6V$$

$$R_1 = 9.1 \text{ K}\Omega, R_2 = 51 \text{ K}\Omega, R_3 = 5.1 \text{ K}\Omega,$$

$$V_r = 2.5 \text{ V}, V_f = 0.46 \text{ V}$$

$$R_{trim_up} = \frac{18.944}{0.6} - 4.636 = 26.94 \text{ (K}\Omega\text{)}$$

The value of Rtrim_down defined as:

$$R_{trim_down} = \frac{R_1 \times (V_o - V_r)}{V_{o_nom} - V_o} - R_2 \text{ (K}\Omega\text{)}$$

Where:

Rtrim_down is the external resistor in KΩ.

V_{o_nom} is the nominal output voltage.

V_o is the desired output voltage.

R₁, R₂, R₃ and V_r are internal components.

For example: to trim-down the output voltage of 12V module (CQB100W-110S12) by 5% to 11.4V, Rtrim_down is calculated as follows:

$$V_{o_nom} - V_o = 12 - 11.4 = 0.6 \text{ V}$$

$$R_1 = 9.1 \text{ K}\Omega, R_2 = 51 \text{ K}\Omega, V_r = 2.5 \text{ V}$$

$$R_{trim_down} = \frac{9.1 \times (11.4 - 2.5)}{0.6} - 51 = 83.98 \text{ (K}\Omega\text{)}$$

The typical value of Rtrim_up

Trim up (%)	5V	12V	15V	24V	28V	48V
	Rtrim_up (KΩ)					
1%	112.7	153.2	163.3	165.7	168.3	148.6
2%	54.70	74.30	78.32	79.36	81.16	71.81
3%	35.37	47.99	49.98	50.58	52.12	46.21
4%	25.70	34.83	35.80	36.19	37.60	33.40
5%	19.90	26.94	27.30	27.56	28.86	25.72
6%	16.03	21.68	21.63	21.80	23.08	20.60
7%	13.27	17.92	17.58	17.69	18.93	16.94
8%	11.20	15.10	14.55	14.61	15.82	14.20
9%	9.589	12.91	12.18	12.21	13.40	12.07
10%	8.300	11.15	10.29	10.29	11.47	10.36

The typical value of Rtrim_down

Trim down %	5V	12V	24V	28V	48V
	Rtrim_down(KΩ)				
1%	110.4	660.3	1671	1984	3106
2%	52.38	300.1	775.8	905.5	1400
3%	33.05	180.0	477.2	545.8	831.5
4%	23.38	120.0	327.9	365.9	547.1
5%	17.58	83.99	238.3	258.0	376.5
6%	13.71	59.97	178.6	186.0	262.8
7%	10.95	42.82	136.0	134.6	181.5
8%	8.880	29.95	104.0	96.10	120.6
9%	7.269	19.95	79.07	66.12	73.17
10%	5.980	11.94	59.17	42.14	35.25

The 15Vout typical value of Rtrim_down

Trim down (%)	Rtrim_down(KΩ)	Trim down (%)	Rtrim_down(KΩ)
1%	952.0	11%	42.91
2%	452.0	12%	35.33
3%	285.3	13%	28.92
4%	202.0	14%	23.43
5%	152.0	15%	18.67
6%	118.6	16%	14.50
7%	94.86	17%	10.82
8%	77.00	18%	7.56
9%	63.11	19%	4.63
10%	52.00	20%	2.00



CQB100W-110SXX Series Application Note V12

6.11 Output Remote Sensing

The CQB100W-110SXX series converter has the capability to remotely sense both lines of its output. This feature moves the effective output voltage regulation point from the output of the unit to the point of connection of the remote sense pins. This feature automatically adjusts the real output voltage of the CQB100W-110SXX series in order to compensate for voltage drops in distribution and maintain a regulated voltage at the point of load. The remote-sense voltage range is:

$$[(+V_{out}) - (-V_{out})] - [(+Sense) - (-Sense)] \leq 10\% \text{ of } V_{o_nominal}$$

When remote sense is in use, the sense should be connected by twisted-pair wire or shield wire. If the sensing patterns short, heavy current flows and the pattern may be damaged. Output voltage might become unstable because of impedance of wiring and load condition when length of wire is exceeding 400mm. This is shown in the schematic below.

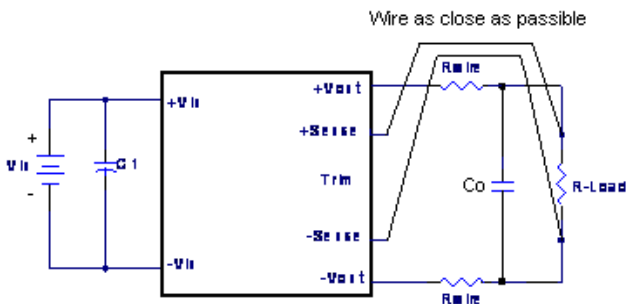

If the remote sense feature is not to be used, the sense pins should be connected locally. The +Sense pin should be connected to the +Vout pin at the module and the -Sense pin should be connected to the -Vout pin at the module. Wire between +Sense and +Vout and between -Sense and -Vout as short as possible. Loop wiring should be avoided. The converter might become unstable by noise coming from poor wiring. This is shown in the schematic below.

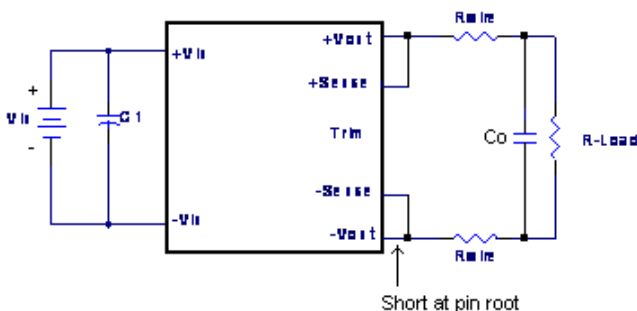

Note: Although the output voltage can be varied (increased or decreased) by both remote sense and trim, the maximum variation for the output voltage is the larger of the two values not the sum of the values. The output power delivered by the module is defined as the voltage at the output terminals multiplied by the output current. Using remote sense and trim can cause the output voltage to increase and consequently increase the power output of the module if output current remains unchanged. Always ensure that the output power of the module remains at or below the maximum rated power. Also be aware that if V_{o_set} is below nominal value, P_{out_max} will also decrease accordingly because I_{o_max} is an absolute limit. Thus, $P_{out_max} = V_{o_set} \times I_{o_max}$ is also an absolute limit.

6.12 Output Ripple and Noise

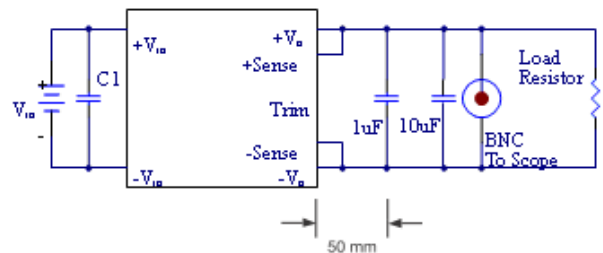

Output ripple and noise measured with 10uF aluminum and 1uF ceramic capacitors across output for 48Vout and with 10uF tantalum and 1uF ceramic capacitors for others. A 20 MHz bandwidth oscilloscope is normally used for the measurement.

The conventional ground clip on an oscilloscope probe should never be used in this kind of measurement. This clip, when placed in a field of radiated high frequency energy, acts as an antenna or inductive pickup loop, creating an extraneous voltage that is not part of the output noise of the converter.





CQB100W-110SXX Series Application Note V12

Another method is shown in below, in case of coaxial-cable/BNC is not available. The noise pickup is eliminated by pressing scope probe ground ring directly against the -Vout terminal while the tip contacts the +Vout terminal. This makes the shortest possible connection across the output terminals.

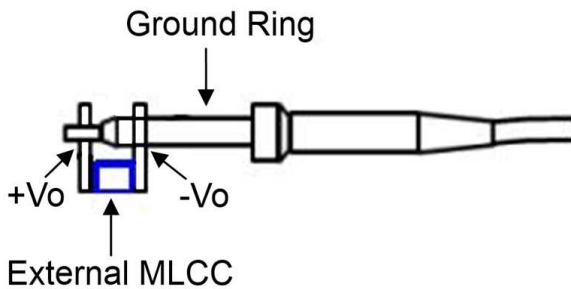

6.13 Output Capacitance

The CQB100W-110SXX series converters provide unconditional stability with or without external capacitors. For good transient response, low ESR output capacitors should be located close to the point of load (<100mm). PCB design emphasizes low resistance and inductance tracks in consideration of high current applications. Output capacitors with their associated ESR values have an impact on loop stability and bandwidth. Cincon's converters are designed to work with load capacitance to see technical specifications.

6.14 Remote On/Off circuit

The converter remote On/Off circuit built-in on input side. The ground pin of input side Remote On/Off circuit is -Vin pin. Refer to 5.5 for more details. Inside connection sees below.

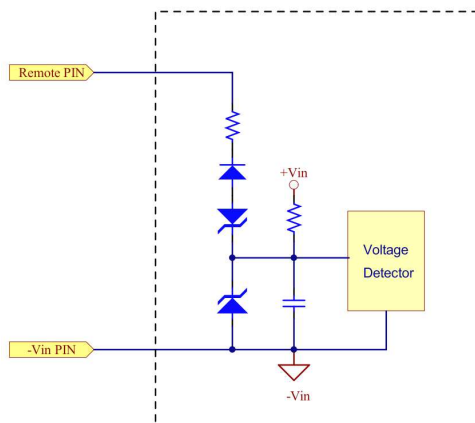

Connection examples see below.

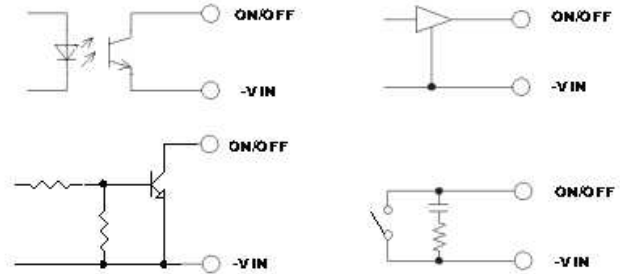

Remote On/Off Connection Example

6.15 Series Operation

Series operation is possible by connecting the outputs two or more units. Connection is shown in below. The output current in series connection should be lower than the lowest rate current in each power module.

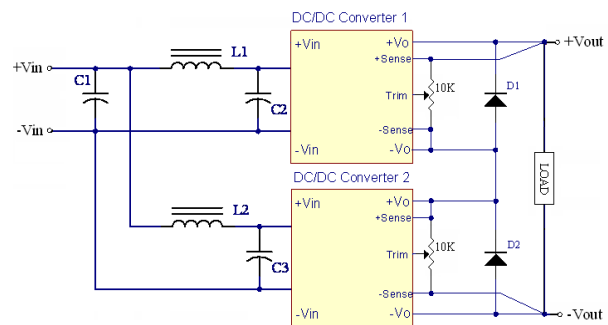

Simple Series Operation Connect Circuit

L1, L2: 1.0uH
C1, C2, C3: 220uF/200V ESR<0.07Ω

Note:

1. If the impedance of input line is high, C1, C2, C3 capacitance must be more than above. Use more than two recommended capacitor above in parallel when ambient temperature becomes lower than -20°C.
2. Recommend Schottky diode (D1, D2) be connected across the output of each series connected converter, so that if one converter shuts down for any reason, then the output stage won't be thermally overstressed. Without this external diode, the output stage of the shut-down converter could carry the load current provided by the other series converters, with its MOSFETs conducting through the body diodes. The MOSFETs could then be overstressed and fail. The external diode should be capable of handling the full load current for as long as the application is expected to run with any unit shut down.

Series for ±output operation is possible by connecting the outputs two units, as shown in the schematic below.



CQB100W-110SXX Series Application Note V12

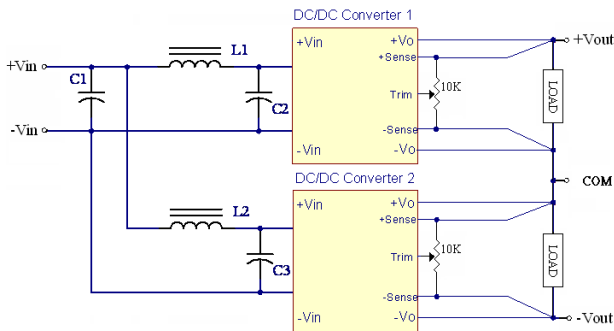

Simple ±Output Operation Connect Circuit

L1, L2: 1.0uH

C1, C2, C3: 220uF/200V ESR<0.07Ω

Note:

If the impedance of input line is high, C1, C2, C3 capacitance must be more than above. Use more than two recommended capacitor above in parallel when ambient temperature becomes lower than -20°C.

6.16 Parallel/Redundant Operation

The CQB100W-110SXX series parallel operation is **not** possible.

Parallel for redundancy operation is possible by connecting the units as shown in the schematic below. The current of each converter become unbalance by a slight difference of the output voltage. Make sure that the output voltage of units of equal value and the output current from each power supply does not exceed the rate current. Suggest use an external potentiometer to adjust output voltage from each power supply.

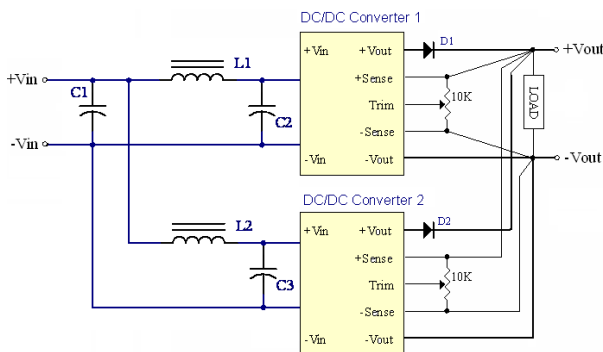

Simple Redundant Operation Connect Circuit

L1, L2: 1.0uH

C1, C2, C3: 220uF/200V ESR<0.07Ω

Note:

If the impedance of input line is high, C1, C2, C3 capacitance must be more than above. Use more than two recommended capacitor above in parallel when ambient temperature becomes lower than -20°C.



CQB100W-110SXX Series Application Note V12

CQB100W-110S05

Line

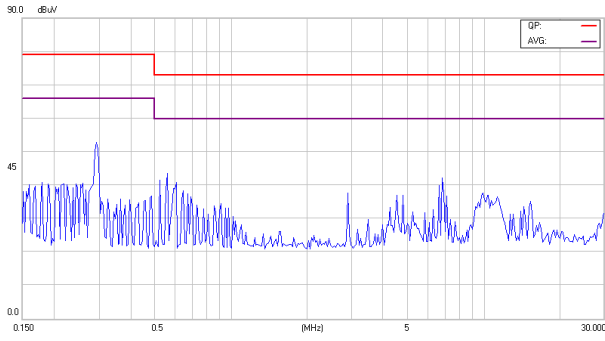

Neutral

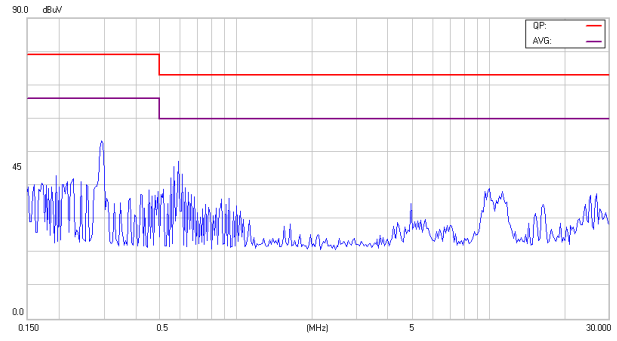

CQB100W-110S12

Line

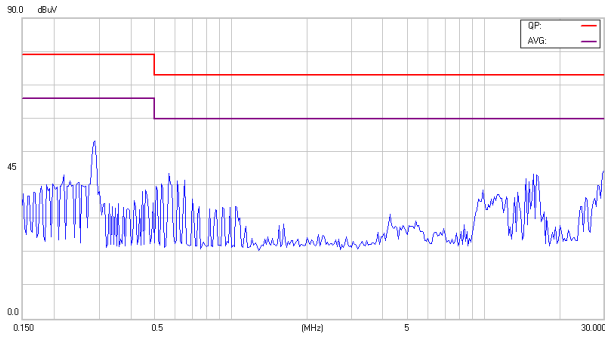

Neutral

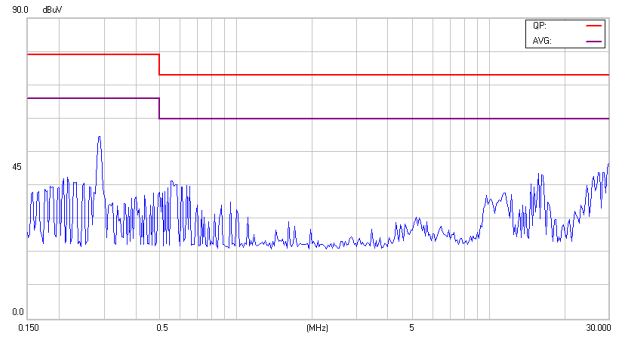

CQB100W-110S15

Line

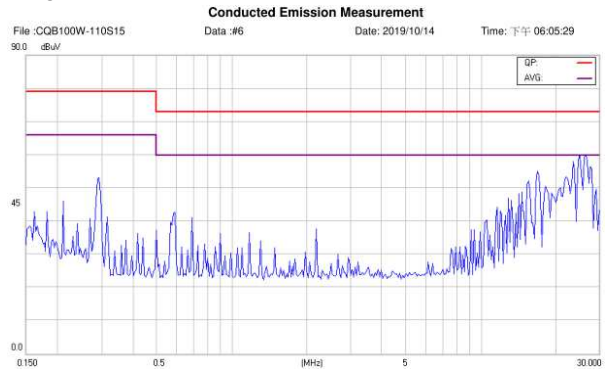

Neutral

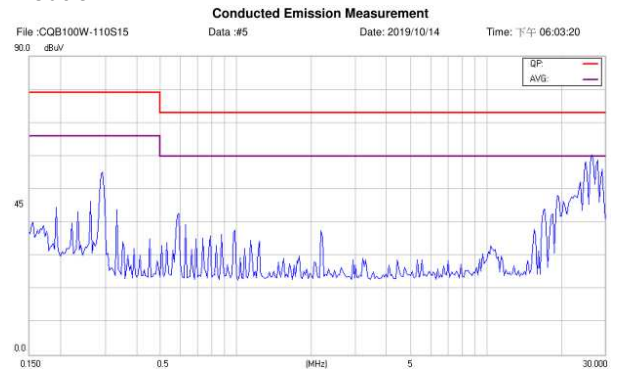

CQB100W-110S24

Line

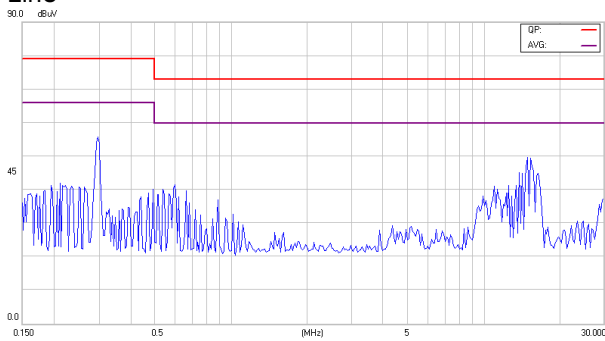

Neutral

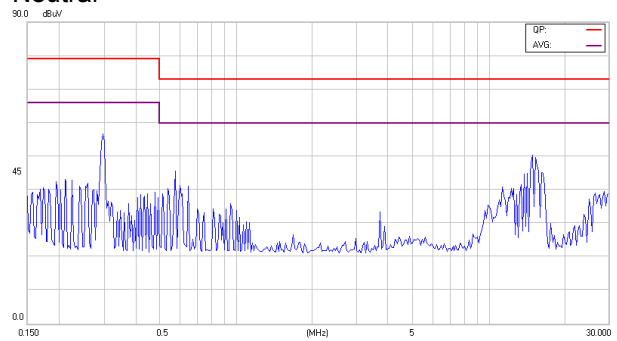



CQB100W-110SXX Series Application Note V12

CQB100W-110S28

Line

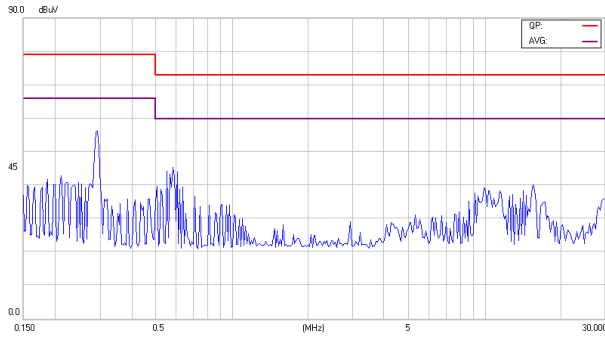

Neutral

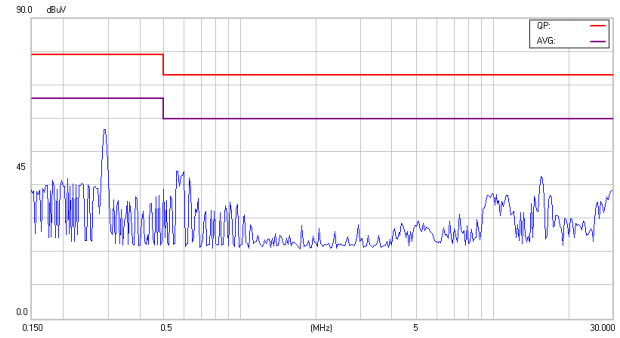

CQB100W-110S48

Line

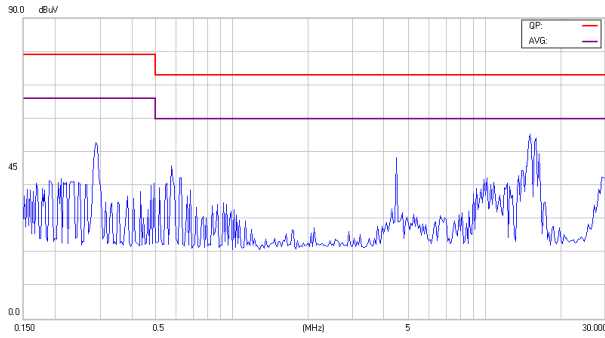

Neutral

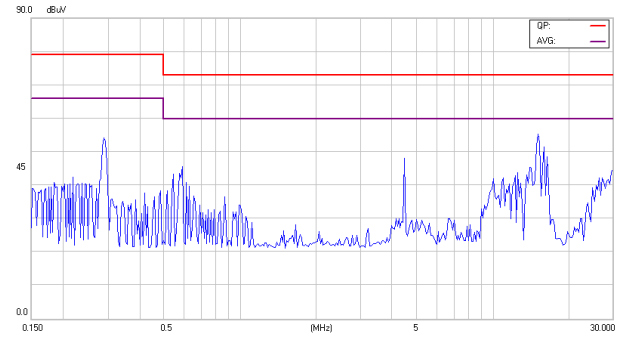

7.3 Suggested Configuration for RIA12 Surge Test

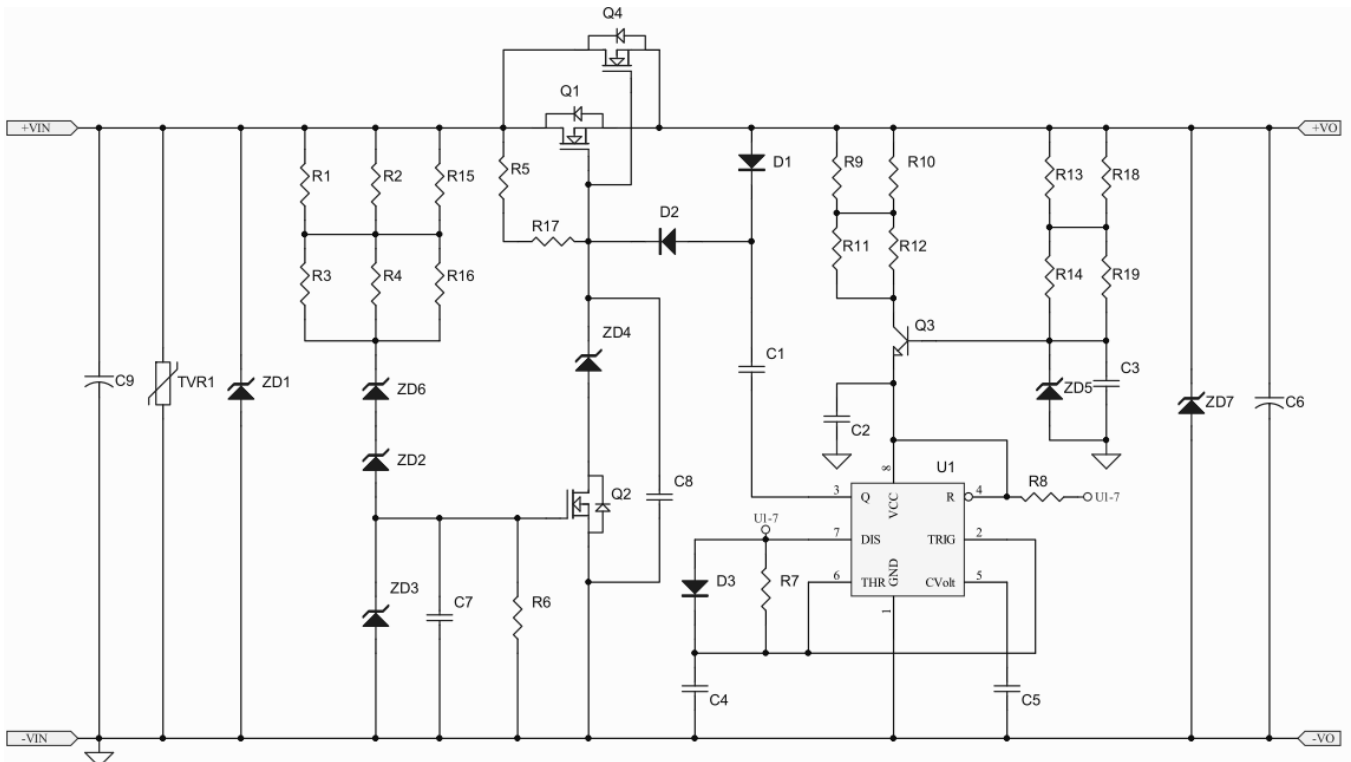



CQB100W-110SXX Series Application Note V12

8. Part Number

Format: CQB100W – II OXX L-Y

Parameter	Series	Nominal Input Voltage	Number of Outputs	Output Voltage	Remote On/Off Logic	Mounting Inserts
Symbol	CQB100W-	II	O	XX	L	Y (Option)
Value	CQB100W-	110: 110 Volts	S: Single	05: 5.0 Volts 12: 12 Volts 15: 15 Volts 24: 24 Volts 28: 28 Volts 48: 48 Volts	None: Positive N: Negative	C: Clear Mounting Insert (3.2mm DIA.)

9. Mechanical Specifications

9.1 Mechanical Outline Diagrams

All Dimensions In Inches(mm)
Tolerances Inches: X.XX= ±0.02 , X.XXX= ±0.010
Millimeters: X.X= ±0.5 , X.XX=±0.25

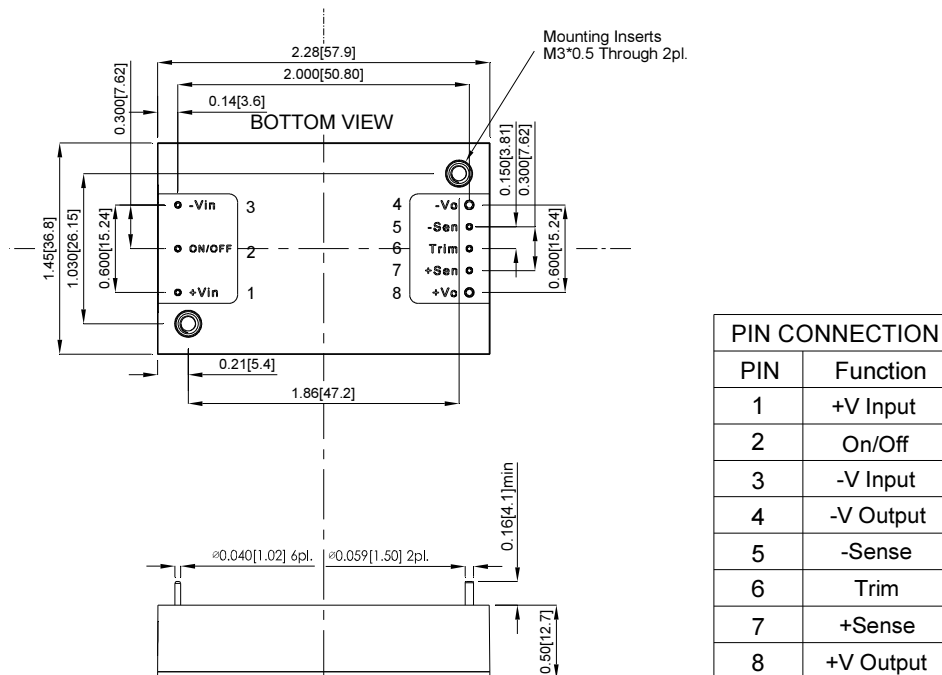

CQB100W-110SXX Mechanical Outline Diagram

CINCON ELECTRONICS CO., LTD.

Headquarters:

14F, No.306, Sec.4, Hsin Yi Rd.
Taipei, Taiwan
Tel: 886-2-27086210
Fax: 886-2-27029852
E-mail: support@cincon.com.tw
Web Site: <http://www.cincon.com>

Factory:

No. 8-1, Fu Kung Rd.
Fu Hsing Industrial Park
Fu Hsing Hsiang,
ChangHua Hsien, Taiwan
Tel: 886-4-7690261
Fax: 886-4-7698031

Cincon North America:

1655Mesa Verde Ave. Ste 180
Ventura, CA93003
Tel: 805-639-3350
Fax: 805-639-4101
E-mail: info@cincon.com