



# CQB75W14 Series Application Note February 2026 V14

## ISOLATED DC-DC CONVERTER CQB75W14 SERIES APPLICATION NOTE



**Approved By:**

Department	Approved By	Checked By	Written By
Research and Development Department	Jacky	Astray/Elsie	Miko
Design Quality Department	Benny	JoJo	



# CQB75W14 Series

## Application Note February 2026 V14

---

### Contents

1. Introduction .....	3
2. Pin Function Description .....	3
3. Connection for Standard Use .....	4
4. Test Set-Up .....	4
5. Recommend Layout, PCB Footprint and Soldering Information .....	5
6. Features and Functions .....	5
6.1 UVLO (Under Voltage Lock Out) .....	5
6.2 Over Current/Short Circuit Protection .....	6
6.3 Output Over Voltage Protection .....	6
6.4 Over Temperature Protection .....	6
6.5 Remote On/Off .....	6
6.6 Output Remote Sensing .....	7
6.7 Output Voltage Adjustment .....	8
7. Input/Output Considerations .....	9
7.1 Input Capacitance at the Power Module .....	9
7.2 Hold up Time .....	9
7.3 Output Ripple and Noise .....	10
7.4 Output Capacitance .....	10
8. Series and Parallel Operation .....	11
8.1 Series Operation .....	11
8.2 Parallel Operation .....	11
8.3 Redundant Operation .....	11
9. Thermal Design .....	12
9.1 Operating Temperature Range .....	12
9.2 Convection Requirements for Cooling .....	12
9.3 Thermal Considerations .....	12
9.4 Power Derating .....	12
9.5 Quarter Brick Heat Sinks .....	14
10. Safety & EMC .....	14
10.1 Input Fusing and Safety Considerations .....	14
10.2 EMC Considerations .....	14
10.3 Suggested Configuration for RIA12 Surge Test .....	23



# CQB75W14 Series

## Application Note February 2026 V14

### 1. Introduction

The CQB75W14 series of DC-DC converters offers 75 watts of output power at single output voltages of 5, 12, 15, 24, 28, 54VDC with industry standard quarter-brick. It has a ultrawide (14:1) input voltage range of 12 to 160VDC (72VDC nominal) and 3000VAC reinforced isolation.

Compliant with EN 50155, EN 45545, EN 50121-3-2. High efficiency up to 91%, allowing case operating temperature range of -40°C to 105°C. An optional heat sink is available to extend the full power range of the unit. Very low no load power consumption (20mA), an ideal solution for energy critical systems.

The standard control functions include remote **on/off** (positive or negative) and +15% to -20% (except for 54V<sub>out</sub> +10% to -20%) adjustable output voltage.

Fully protected against input UVLO (under voltage lock out), output over-current, output over-voltage, over-temperature and continuous short circuit conditions.

CQB75W14 s

eries is designed primarily for common railway applications of 24V, 36V, 48V, 72V, 96V, 110V nominal voltage and also suitable for distributed power architectures, telecommunications, battery operated equipment and industrial applications.

### 2. Pin Function Description

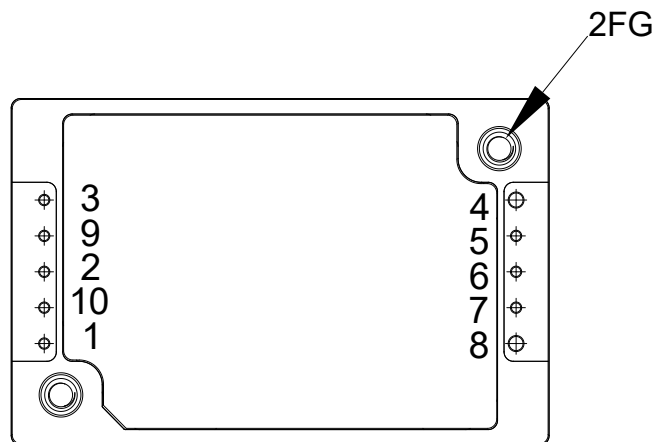

No	Label	Function	Description	Reference
1	+Vin	+V Input	Positive Supply Input	<b>Section 7.1/7.2</b>
2	ON/OFF	On/Off	External Remote On/Off Control	<b>Section 6.5</b>
3	-Vin	-V Input	Negative Supply Input	<b>Section 7.1/7.2</b>
4	-Vo	-V Output	Negative Power Output	<b>Section 7.3/7.4</b>
5	-Sen	-Sense	Negative Output Remote Sense	<b>Section 6.6</b>
6	Trim	Trim	External Output Voltage Adjustment	<b>Section 6.7</b>
7	+Sen	+Sense	Positive Output Remote Sense	<b>Section 6.6</b>
8	+Vo	+V Output	Positive Power Output	<b>Section 7.3/7.4</b>
9	Bus	Bus	Pre-Regulator Voltage Output (Option)	<b>Section 7.2</b>
10	UVLO	UVLO	External UVLO Function (Option)	<b>Section 6.1</b>
--	--	Mounting Insert	Mounting Insert (FG)	<b>Section 9.5/10.2</b>

Note: Base plate can be connected to FG through M3 threaded mounting insert. Recommended torque 3-5Kgf-cm.



# CQB75W14 Series

## Application Note February 2026 V14

### 3. Connection for Standard Use

The connection for standard use is shown below. An external input capacitor (C1) 220uF for all models is recommended to reduce input ripple voltage. External output capacitors (C2, C3) are recommended to reduce output ripple and noise, 10uF polymer tantalum and 1uF ceramic capacitors for all models.

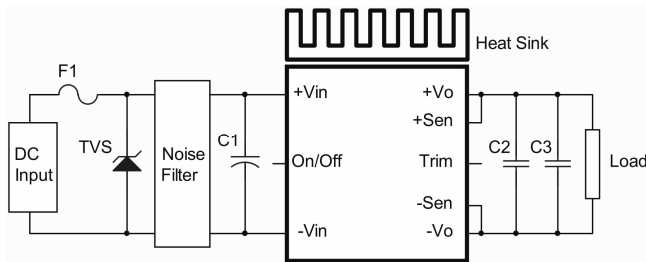

Symbol	Component	Reference
F1, TVS	Input fuse, TVS	<b>Section 10.1</b>
C1	External capacitor on the input side	<b>Note Section 7.2</b>
C2, C3	External capacitor on the output side	<b>Section 7.3/7.4</b>
Noise Filter	External input noise filter	<b>Section 10.2</b>
Remote On/Off	External remote on/off control	<b>Section 6.5</b>
Trim	External output voltage adjustment	<b>Section 6.7</b>
Heat Sink	External heat sink	<b>Section 9.2/9.3/9.4/9.5</b>
+Sense/-Sense	--	<b>Section 6.6</b>

**Note:**

If the impedance of input line is high, C1 capacitance must be more than above. Use more than two recommended capacitors above in parallel when ambient temperature becomes lower than -20°C.

### 4. Test Set-Up

The basic test set-up to measure parameters such as efficiency and load regulation is shown below. When testing the modules under any transient conditions please ensure that the transient response of the source is sufficient to power the equipment under test. We can calculate:

- Efficiency
- Load regulation and line regulation

The value of efficiency is defined as:

$$\eta = \frac{V_o \times I_o}{V_{in} \times I_{in}} \times 100\%$$

Where:

- $V_o$  is output voltage,
- $I_o$  is output current,
- $V_{in}$  is input voltage,
- $I_{in}$  is input current

The value of load regulation is defined as:

$$Load\ reg. = \frac{V_{FL} - V_{NL}}{V_{NL}} \times 100\%$$

Where:

- $V_{FL}$  is the output voltage at full load
- $V_{NL}$  is the output voltage at no load

The value of line regulation is defined as:

$$Line\ reg. = \frac{V_{HL} - V_{LL}}{V_{LL}} \times 100\%$$

Where:

- $V_{HL}$  is the output voltage of maximum input voltage at full load
- $V_{LL}$  is the output voltage of minimum input voltage at 80% full load

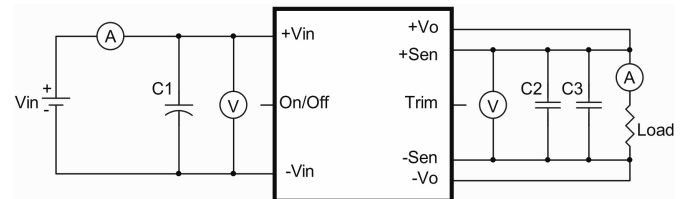

**CQB75W14 Series Test Setup**

- C1: 220uF/200V ESR<0.047Ω
- C2: 1uF/1210 ceramic capacitor
- C3: 10uF polymer tantalum capacitor (ESR≤0.05Ω)



# CQB75W14 Series

## Application Note February 2026 V14

### 5. Recommend Layout, PCB Footprint and Soldering Information

The system designer or end user must ensure that metal and other components in the vicinity of the converter meet the spacing requirements for which the system is approved. Low resistance and inductance PCB layout traces are the norm and should be used where possible. Due consideration must also be given to proper low impedance tracks between power module, input and output grounds.

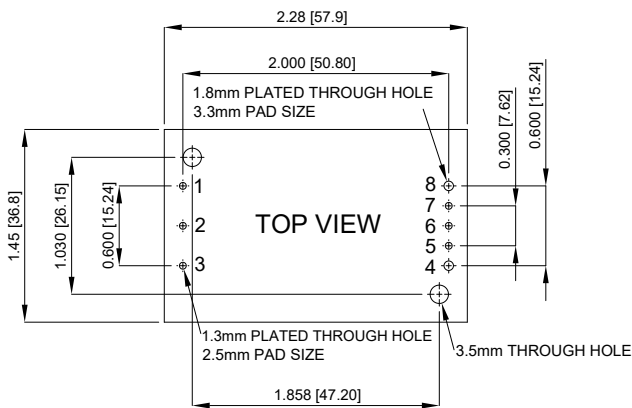

Standard Module

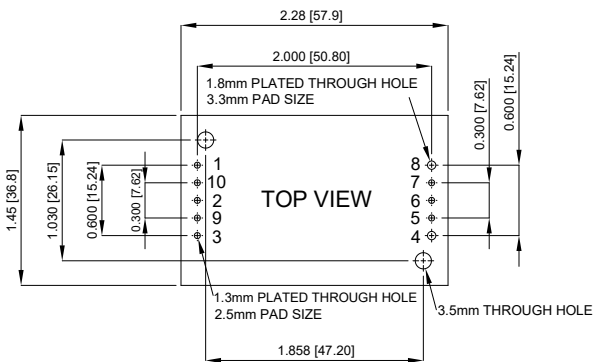

Option Module

Clean the soldered side of the module with a brush, prevent liquid from getting into the module. Do not clean by soaking the module into liquid. Do not allow solvent to come in contact with product labels or resin case as this may change the color of the resin case or cause deletion of the letters printed on the product label. After cleaning, dry the modules well.

The suggested soldering iron is 450°C for up to 5 seconds (less than 50W). Furthermore, the recommended soldering profile is shown below, and PCB layout is referring to section 10.2.

Lead Free Wave Soldering Profile

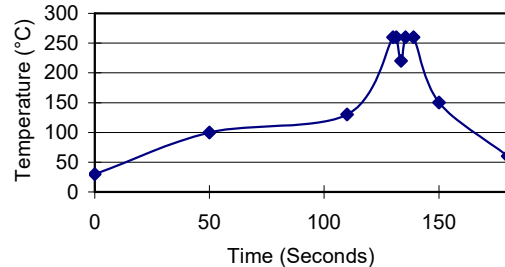

### 6. Features and Functions

#### 6.1 UVLO (Under Voltage Lock Out)

Input under voltage lockout is standard on the CQB75W14 series unit. The unit will shut down when the input voltage drops below a threshold, and the unit will operate when the input voltage goes above the upper threshold.

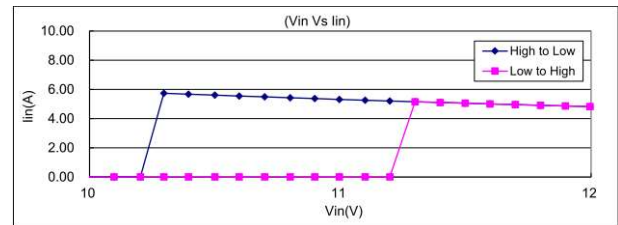

And the CQB75W14 series has an adjustable under voltage lockout which will shut down the converter according to following settings.

Nom. Input Voltage (VDC)	24	36	48	72	110
Turn Off Threshold (VDC)	13.8 ±0.75	20.8 ±0.75	28.0 ±1.0	42.5 ±1.5	53.0 ±3.0
Turn On Threshold (VDC)	14.8 ±0.75	21.8 ±0.75	29.0 ±1.0	43.5 ±1.5	54.0 ±3.0
R1 Resistor (KΩ) (UVLO to +V <sub>in</sub> )	Open	Open	Open	Open	240
R2 Resistor (KΩ) (UVLO to -V <sub>in</sub> )	18.84	6.1	3.64	2.0	1.18

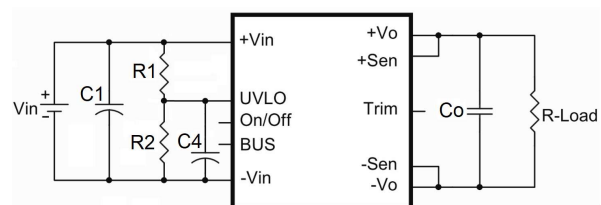

C1: 220uF/200V ESR<0.047Ω

C4: 0.01uF/50V ceramic capacitor



# CQB75W14 Series

## Application Note February 2026 V14

### 6.2 Over Current/Short Circuit Protection

All models have internal over current and continuous short circuit protection. The unit operates normally once the fault condition is removed. At the point of current limit inception, the converter will go into hiccup mode protection.

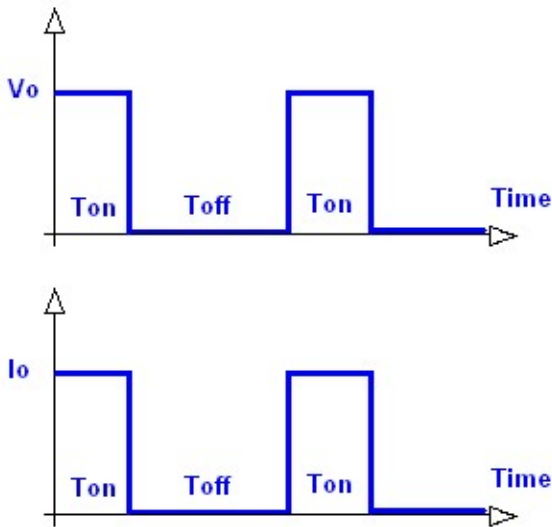

### 6.3 Output Over Voltage Protection

The output over voltage protection consists of circuitry that internally limits the output voltage. If more accurate output over voltage protection is required, then an external circuit can be used via the remote **on/off** pin.

**Note:**

Please note that device inside the power supply might fail when voltage more than rate output voltage is applied to output pin. This could happen when the customer tests the over voltage protection of unit. OVP can be tested by using the TRIM UP function. Consult us for more information.

### 6.4 Over Temperature Protection

These modules have an over temperature protection circuit to safeguard against thermal damage. Shutdown occurs with the maximum case reference temperature is exceeded. The module will restart when the case temperature falls below over temperature recovery threshold. Please measure case temperature of the center part of aluminum base plate.

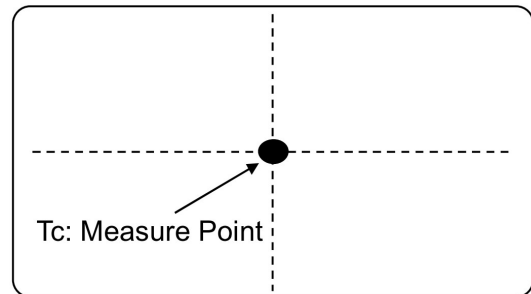
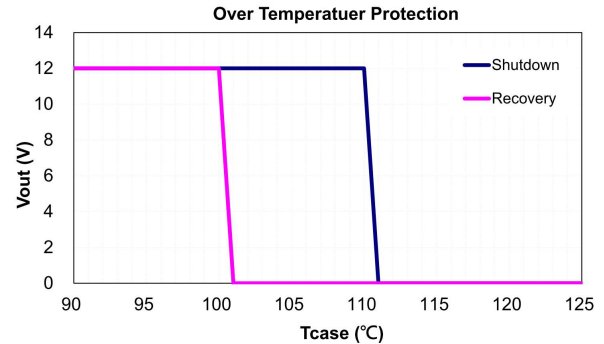

### 6.5 Remote On/Off

The CQB75W14 series allows the user to switch the module on and off electronically with the remote **on/off** feature. All models are available in “positive logic” and “negative logic” (optional) versions. The converter turns on if the remote **on/off** pin is high (>3.5V<sub>dc</sub> to 160V<sub>dc</sub> or open circuit). Setting the pin low (0 to <1.2V<sub>dc</sub>) will turn the converter off. The signal level of the remote **on/off** input is defined with respect to ground.

If not using the remote **on/off** pin, leave the pin open (converter will be on).

Models with part number suffix “N” are the “negative logic” remote **on/off** version. The unit turns off if the remote **on/off** pin is high (>3.5V<sub>dc</sub> to 160V<sub>dc</sub> or open circuit). The converter turns on if the **on/off** pin input is low (0 to <1.2V<sub>dc</sub>). Note that the converter is off by default.

Logic State (Pin 2)	Negative Logic	Positive Logic
Logic Low	Module on	Module off
Logic High	Module off	Module on



# CQB75W14 Series

## Application Note February 2026 V14

The converter remote **on/off** circuit built-in on input side. The ground pin of input side remote **on/off** circuit is  $-V_{in}$  pin. Inside connection sees below.

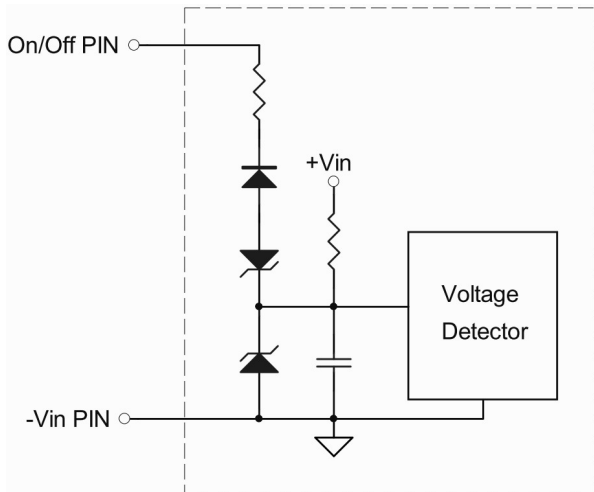

Connection examples see below.

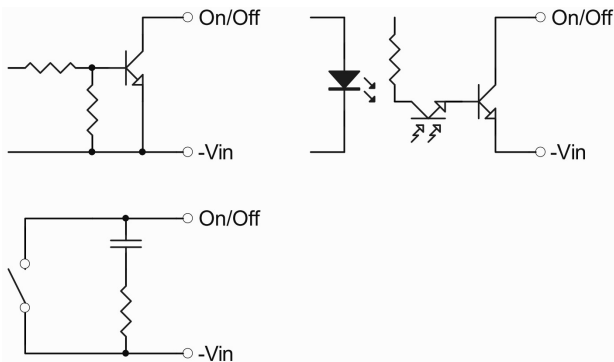

**Remote On/Off Connection Example**

### 6.6 Output Remote Sensing

The CQB75W14 series converter has the capability to remotely sense both lines of its output. This feature moves the effective output voltage regulation point from the output of the unit to the point of connection of the remote sense pins. This feature automatically adjusts the real output voltage of the CQB75W14 series in order to compensate for voltage drops in distribution and maintain a regulated voltage at the point of load. The remote-sense voltage range is:

For  $V_o=54V$

$$[(+V_{out}) - (-V_{out})] - [(+Sense) - (-Sense)] \leq 10\% \text{ of } V_{o\_nominal}$$

For Others

$$[(+V_{out}) - (-V_{out})] - [(+Sense) - (-Sense)] \leq 15\% \text{ of } V_{o\_nominal}$$

When remote sense is in use, the sense should be connected by twisted-pair wire or shield wire. If the sensing patterns short, heavy current flows and the pattern may be damaged. Output voltage might become unstable because impedance of wiring and load condition when length of wire is exceeding 400mm. This is shown in the schematic below.

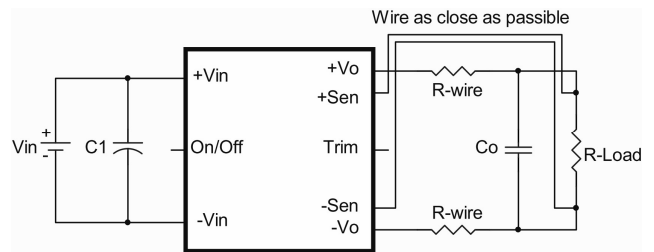

If the remote sense feature is not to be used, the sense pins should be connected locally. The +Sense pin should be connected to the  $+V_{out}$  pin at the module and the -Sense pin should be connected to the  $-V_{out}$  pin at the module. Wire between +Sense and  $+V_{out}$  and between -Sense and  $-V_{out}$  as short as possible. Loop wiring should be avoided. The converter might become unstable by noise coming from poor wiring. This is shown in the schematic below.

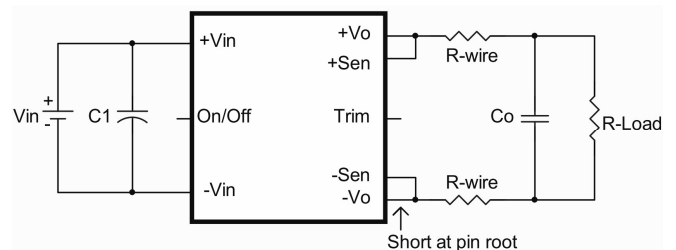

**Note:**

Although the output voltage can be varied (increased or decreased) by both remote sense and trim, the maximum variation for the output voltage is the larger of the two values not the sum of the values. The output power delivered by the module is defined as the voltage at the output terminals multiplied by the output current. Using remote sense and trim can cause the output voltage to increase and consequently increase the power output of the module if output current remains unchanged. Always ensure that the output power of the module remains at or below the maximum rated power. Also be aware that if  $V_{o.set}$  is below nominal value,  $P_{out.max.}$  will also decrease accordingly because  $I_{o.max.}$  is an absolute limit. Thus,  $P_{out.max.} = V_{o.set} \times I_{o.max.}$  is also an absolute limit.



# CQB75W14 Series

## Application Note February 2026 V14

### 6.7 Output Voltage Adjustment

Output may be externally trimmed (+15% to -20%, except 54V<sub>out</sub> is +10% to -20%) with a fixed resistor or an external trim pot as shown (optional). Model specific formulas for calculating trim resistors are available upon request as a separate document.

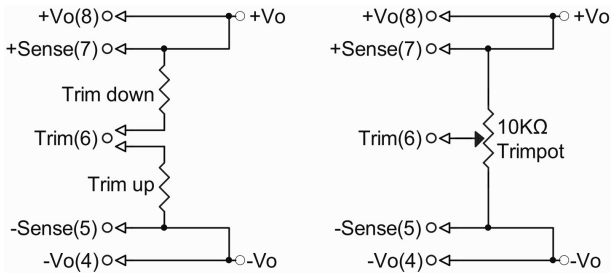

In order to trim the voltage up or down, one needs to connect the trim resistor either between the trim pin and -Sense for trim-up or between trim pin and +Sense for trim-down. The output voltage trim range is +15% to -20%, except 54V<sub>out</sub>, it is +10% to -20%. This is shown:

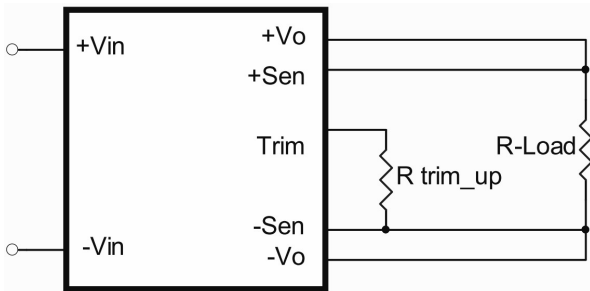

**Trim-up Voltage Setup**

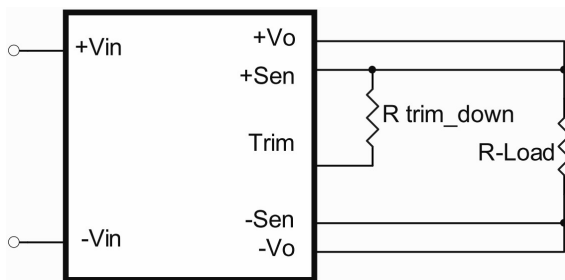

**Trim-down Voltage Setup**

The value of R<sub>trim\_up</sub> defined as:

$$R_{trim\_up} = \left[ \frac{V_r \times R1 \times (R2 + R3)}{R2 \times (V_o - V_{o,nom})} \right] - R_t \text{ (K}\Omega\text{)}$$

Where:

- R<sub>trim\_up</sub> is the external resistor in KΩ
- V<sub>o, nom</sub> is the nominal output voltage
- V<sub>o</sub> is the desired output voltage
- R1, R2, R3, R<sub>t</sub> and V<sub>r</sub> are internal to the unit and are defined in Table 1

Table 1 – Trim up and Trim down Resistor Values

Model Number	Output Voltage(V)	R1 (KΩ)	R2 (KΩ)	R3 (KΩ)	Rt (KΩ)	Vr (V)
CQB75W14-72S05	5.0	6.2	2.37	1	8.2	1.24
CQB75W14-72S12	12.0	6.8	2.37	2.2	10	2.5
CQB75W14-72S15	15.0	9.1	2.32	2.49	12	2.5
CQB75W14-72S24	24.0	15	2.43	5.9	20	2.5
CQB75W14-72S28	28.0	15.4	2.49	10	23.2	2.5
CQB75W14-72S54	54.0	36	2.43	14	51	2.5

For example, to trim-up the output voltage of 12V module (CQB75W14-72S12) by 15% to 13.8V, R<sub>trim\_up</sub> is calculated as follows:

$$R1=6.8K\Omega, R2=2.37K\Omega, R3=2.2K\Omega, R_t=10K\Omega, V_r=2.5V, V_o=13.8V, V_{o,nom}=12V$$

$$R_{trim\_up} = \left[ \frac{2.5 \times 6.8 \times (2.37 + 2.2)}{2.37 \times (13.8 - 12)} \right] - 10 = 8.2 \text{ (K}\Omega\text{)}$$

The typical value of R<sub>trim\_up</sub>

Trim up (%)	5V	12V	15V	24V	28V	54V
	R <sub>trim_up</sub> (KΩ)					
1%	210.44	263.17	302.45	515.62	666.51	1075
2%	101.12	126.59	145.22	247.81	321.65	512.44
3%	64.68	81.06	92.82	158.54	206.70	324.63
4%	46.46	58.29	66.61	113.91	149.23	230.72
5%	35.53	44.63	50.89	87.12	114.74	174.38
6%	28.24	35.53	40.41	69.27	91.75	136.81
7%	23.03	29.02	32.92	56.52	75.33	109.98
8%	19.13	24.15	27.31	46.95	63.01	89.86
9%	16.09	20.35	22.94	39.51	53.43	74.21
10%	13.66	17.32	19.44	33.56	45.77	61.69
11%	11.68	14.83	16.59	28.69	39.50	
12%	10.02	12.76	14.20	24.64	34.28	
13%	8.62	11.01	12.19	21.20	29.85	
14%	7.42	9.51	10.46	18.26	26.06	
15%	6.38	8.21	8.96	15.71	22.78	

The value of R<sub>trim\_down</sub> defined as:

$$R_{trim\_down} = R1 \times \left[ \frac{V_r \times R1}{R2 \times (V_{o,nom} - V_o)} - 1 \right] - R_t \text{ (K}\Omega\text{)}$$

Where:

- R<sub>trim\_down</sub> is the external resistor in KΩ
- V<sub>o, nom</sub> is the nominal output voltage
- V<sub>o</sub> is the desired output voltage
- R1, R2, R3, R<sub>t</sub> and V<sub>r</sub> are internal to the unit and are defined in Table 1



# CQB75W14 Series

## Application Note February 2026 V14

For example: to trim-down the output voltage of 12V module (CQB75W14-72S12) by 20% to 9.6V,  $R_{trim\_down}$  is calculated as follows:

$R_1=6.8K\Omega$ ,  $R_2=2.37K\Omega$ ,  $R_3=2.2K\Omega$ ,  $R_t=10K\Omega$ ,  
 $V_r=2.5V$ ,  $V_o=9.6V$ ,  $V_{o\_nom}=12V$

$$R_{trim\_down} = 6.8 \times \left[ \frac{2.5 \times 6.8}{2.37 \times (12 - 9.6)} - 1 \right] - 10$$

$$= 3.52 (K\Omega)$$

The typical value of  $R_{trim\_down}$

Trim down (%)	5V	12V	15V	24V	28V	54V
	$R_{trim\_down} (K\Omega)$					
1%	387.84	389.67	573.80	929.51	811.80	2382.14
2%	186.72	186.43	276.35	447.25	386.60	1147.57
3%	119.68	118.69	177.20	286.50	244.87	736.05
4%	86.16	84.82	127.62	206.13	174.00	530.28
5%	66.05	64.49	97.88	157.90	131.48	406.83
6%	52.64	50.94	78.05	125.75	103.13	324.52
7%	43.06	41.27	63.89	102.79	82.89	265.73
8%	35.88	34.01	53.26	85.56	67.70	221.64
9%	30.29	28.36	45.00	72.17	55.89	187.35
10%	25.82	23.85	38.39	61.45	46.44	159.91
11%	22.17	20.15	32.98	52.68	38.71	137.47
12%	19.12	17.07	28.47	45.38	32.27	118.76
13%	16.54	14.47	24.66	39.19	26.82	102.93
14%	14.33	12.23	21.39	33.89	22.14	89.37
15%	12.42	10.30	18.56	29.30	18.09	77.61
16%	10.74	8.60	16.08	25.28	14.55	67.32
17%	9.26	7.11	13.89	21.74	11.42	58.24
18%	7.95	5.78	11.95	18.58	8.64	50.17
19%	6.77	4.59	10.21	15.76	6.16	42.95
20%	5.71	3.52	8.64	13.23	3.92	36.46

## 7. Input/Output Considerations

### 7.1 Input Capacitance at the Power Module

The converters must be connected to low AC source impedance. To avoid problems with loop stability source inductance should be low. Also, the input capacitors ( $C_{in}$ ) should be placed close to the converter input pins to de-couple distribution inductance. However, the external input capacitors are chosen for suitable ripple handling capability. Low ESR capacitors are good choice. Circuit as shown as below represents typical measurement methods for reflected ripple current.  $C_1$  and  $L_1$  simulate a typical DC source impedance. The input reflected-ripple current is measured by current probe to oscilloscope with a simulated source Inductance ( $L_1$ ).

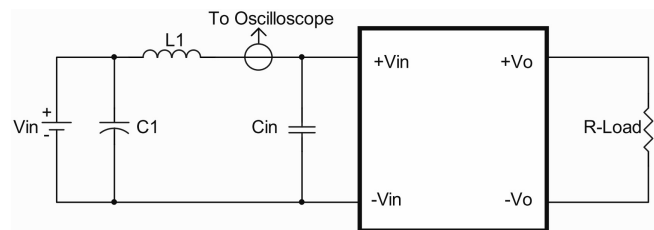

$L_1$ : 12uH

$C_1$ : 220uF/200V ESR<0.047Ω

$C_{in}$ : 220uF/200V ESR<0.047Ω

### 7.2 Hold up Time

Hold up time is defined as the duration of time that the DC/DC converter output will remain active following a loss of input power. The BUS pin is for hold up time function. It is designed to work with an external circuit comprises  $C_5$ . When input power supply is interrupt, the CQB75W14-72S series use the energy stored in  $C_5$  to support operation. A typical configuration shows as below.

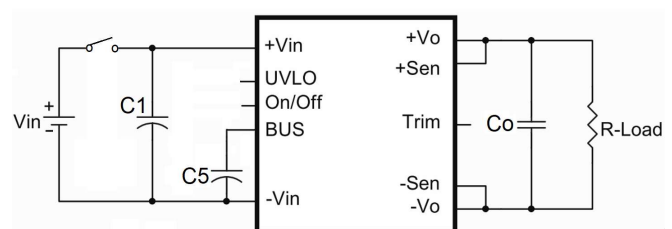

$C_1$ : 220uF/200V ESR<0.047Ω



# CQB75W14 Series

## Application Note February 2026 V14

If hold up time function is not needed, please remove the component(C5). This function provides energy that maintains the DC-DC converter in operation for 10mS and 30mS hold up time. The capacity (C1 & C5) in the application is recommended as below.

V <sub>in</sub>		24V	36V	48V
For 10 mS	C1	220uF		
	C5	10000uF	8200uF	8200uF
For 30 mS	C1	220uF		
	C5	24000uF	16000uF	16000uF

V <sub>in</sub>		72V	96V	110V
For 10 mS	C1	220uF		
	C5	5400uF	3800uF	3800uF
For 30 mS	C1	220uF		
	C5	16800uF	13300uF	12200uF

Note:

C5: 35V rated capacitor

### 7.3 Output Ripple and Noise

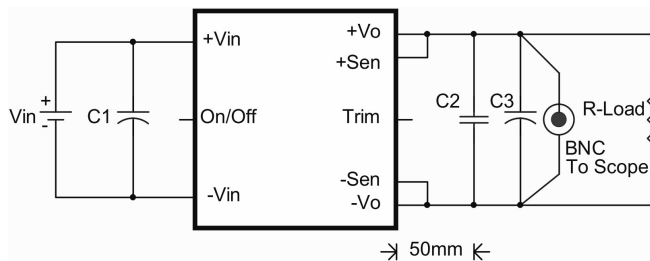

C1: 220uF/200V ESR<0.047Ω

C2: 1uF/1210 ceramic capacitor

C3: 10uF polymer tantalum capacitor (ESR ≤ 0.05Ω)

Output ripple and noise measured with 10uF polymer tantalum capacitor and 1uF ceramic capacitors across output. A 20 MHz bandwidth oscilloscope is normally used for the measurement.

The conventional ground clip on an oscilloscope probe should never be used in this kind of measurement. This clip, when placed in a field of radiated high frequency energy, acts as an antenna or inductive pickup loop, creating an extraneous voltage that is not part of the output noise of the converter.



Another method is shown in below, in case of coaxial-cable/BNC is not available. The noise pickup is eliminated by pressing scope probe ground ring directly against the -V<sub>out</sub> terminal while the tip contacts the +V<sub>out</sub> terminal. This makes the shortest possible connection across the output terminals.

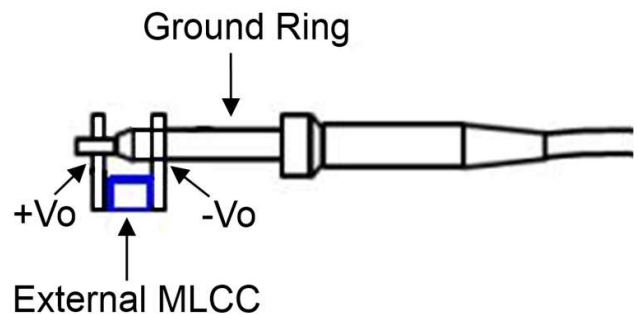

### 7.4 Output Capacitance

The CQB75W14 series converters provide unconditional stability with or without external capacitors. For good transient response, low ESR output capacitors should be located close to the point of load (<100mm). PCB design emphasizes low resistance and inductance tracks in consideration of high current applications. Output capacitors with their associated ESR values have an impact on loop stability and bandwidth. Cincon's converters are designed to work with load capacitance to see specifications.



# CQB75W14 Series

## Application Note February 2026 V14

### 8. Series and Parallel Operation

#### 8.1 Series Operation

Series operation is possible by connecting the outputs two or more units. Connection is shown in below. The output current in series connection should be lower than the lowest rate current in each power module.

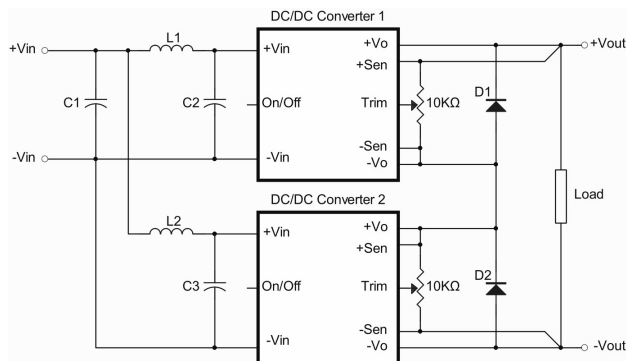

**Simple Series Operation Connect Circuit**

L1, L2: 1.0uH

C1, C2, C3: 220uF/200V ESR<0.047Ω

**Note:**

1. If the impedance of input line is high, C1, C2, C3 capacitance must be more than above. Use more than two recommended capacitor above in parallel when ambient temperature becomes lower than -20°C.
2. Recommend Schottky diode (D1, D2) be connected across the output of each series connected converter, so that if one converter shuts down for any reason, then the output stage won't be thermally overstressed. Without this external diode, the output stage of the shut-down converter could carry the load current provided by the other series converters, with its MOSFETs conducting through the body diodes. The MOSFETs could then be overstressed and fail. The external diode should be capable of handling the full load current for as long as the application is expected to run with any unit shut down.

Series for  $\pm$ output operation is possible by connecting the outputs two units, as shown in the schematic below.

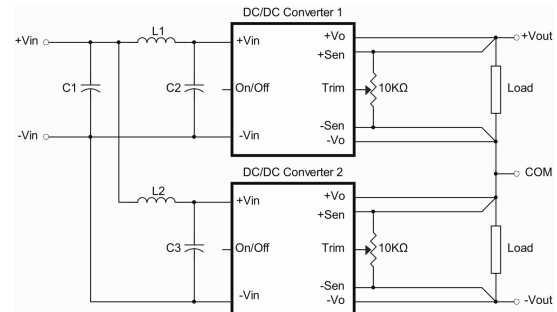

**Simple  $\pm$ Output Operation Connect Circuit**

L1, L2: 1.0uH

C1, C2, C3: 220uF/200V ESR<0.047Ω

**Note:**

If the impedance of input line is high, C1, C2, C3 capacitance must be more than above. Use more than two recommended capacitor above in parallel when ambient temperature becomes lower than -20°C.

#### 8.2 Parallel Operation

The CQB75W14 series parallel operation is not possible.

#### 8.3 Redundant Operation

Parallel for redundancy operation is possible by connecting the units as shown in the schematic below. The current of each converter become unbalance by a slight difference of the output voltage. Make sure that the output voltage of units of equal value and the output current from each power supply does not exceed the rate current. Suggest use an external potentiometer to adjust output voltage from each power supply.

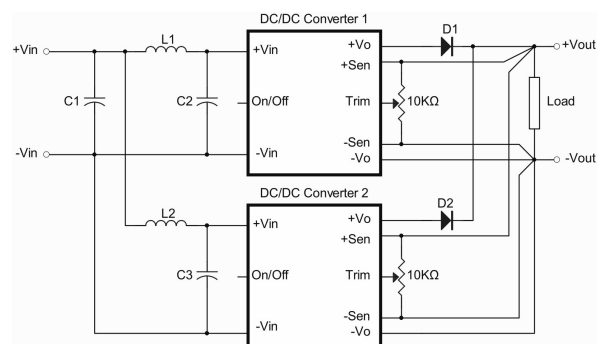

**Simple Redundant Operation Connect Circuit**

L1, L2: 1.0uH

C1, C2, C3: 220uF/200V ESR<0.047Ω

**Note:**

If the impedance of input line is high, C1, C2, C3 capacitance must be more than above. Use more than two recommended capacitor above in parallel when ambient temperature becomes lower than -20°C.



# CQB75W14 Series

## Application Note February 2026 V14

### 9. Thermal Design

#### 9.1 Operating Temperature Range

The CQB75W14 series converters can be operated within a wide case temperature range of -40°C to 105°C. Consideration must be given to the derating curves when ascertaining maximum power that can be drawn from the converter. The maximum power drawn from open quarter brick models is influenced by usual factors, such as:

- Input voltage range
- Output load current
- Forced air or natural convection
- Heat sink optional

#### 9.2 Convection Requirements for Cooling

To predict the approximate cooling needed for the quarter brick module, refer to the power derating curves in **section 9.4**. These derating curves are approximations of the ambient temperatures and airflows required to keep the power module temperature below its maximum rating. Once the module is assembled in the actual system, the module's temperature should be monitored to ensure it does not exceed 105°C as measured at the center of the top of the case (thus verifying proper cooling).

#### 9.3 Thermal Considerations

The power module operates in a variety of thermal environments; however, sufficient cooling should be provided to help ensure reliable operation of the unit. Heat is removed by conduction, convection, and radiation to the surrounding environment. The example is presented in **section 9.4**. The power output of the module should not be allowed to exceed rated power ( $V_{o\_set} \times I_{o\_max}$ ).

#### 9.4 Power Derating

The operating case temperature range of CQB75W14 series is -40°C to +105°C. When operating the CQB75W14 series, proper derating or cooling is needed. The maximum case temperature under any operating condition should not exceed 105°C.

The following curve is the de-rating curve of CQB75W14 series without heat sink.

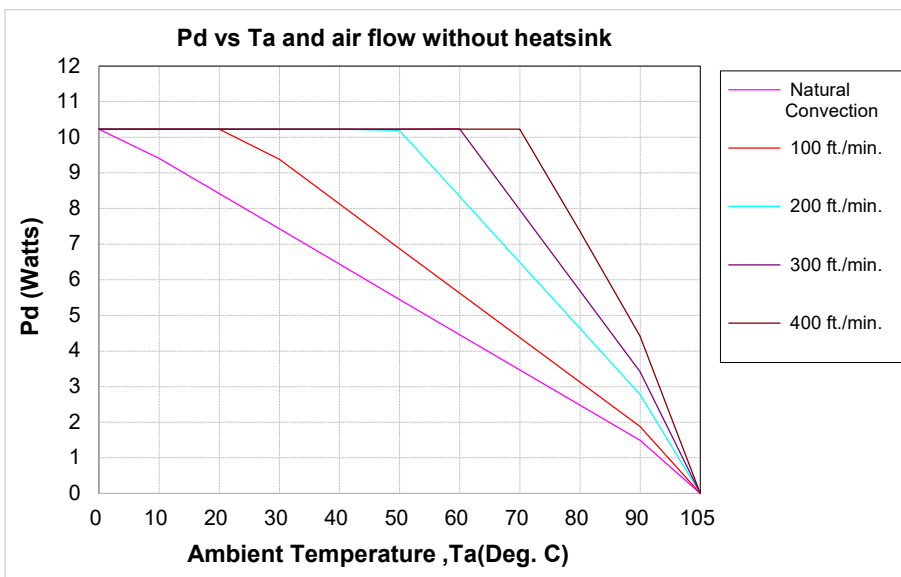

AIR FLOW RATE	TYPICAL $R_{ca}$
Natural Convection 20ft./min. (0.1m/s)	10.1 °C/W
100 ft./min. (0.5m/s)	8.0 °C/W
200 ft./min. (1.0m/s)	5.4 °C/W
300 ft./min. (1.5m/s)	4.4 °C/W
400 ft./min. (2.0m/s)	3.4 °C/W



# CQB75W14 Series

## Application Note February 2026 V14

**Example:**

What is the minimum airflow necessary for a CQB75W14-72S12 operating at nominal line voltage, an output current of 6.25A, and a maximum ambient temperature of 65°C?

**Solution:**

**Given:**  $V_{in}=72V_{dc}$ ,  $V_o=12V_{dc}$ ,  $I_o=6.25A$

**Determine power dissipation ( $P_d$ ):**  $P_d=P_i-P_o=P_o(1-\eta)/\eta$ ,  $P_d=12 \times 6.25 \times (1-0.88)/0.88=10.23Watts$

**Determine airflow:** Given:  $P_d=10.23W$  and  $T_a=65^\circ C$

**Check power derating curve:** Minimum airflow=400ft./min.

**Verify:**

Maximum temperature rise is  $\Delta T=P_d \times R_{ca}=10.23 \times 3.4=34.782^\circ C$

Maximum case temperature is  $T_c=T_a+\Delta T=99.782^\circ C < 105^\circ C$

**Where:**

The  $R_{ca}$  is thermal resistance from case to ambient environment

$T_a$  is ambient temperature and  $T_c$  is case temperature

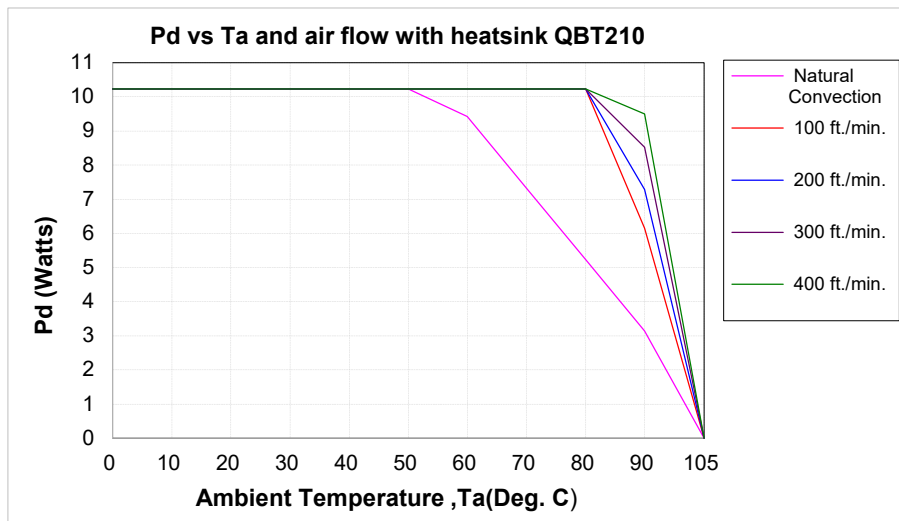

AIR FLOW RATE	TYPICAL $R_{ca}$
Natural Convection 20ft./min. (0.1m/s)	4.78 °C/W
100 ft./min. (0.5m/s)	2.44 °C/W
200 ft./min. (1.0m/s)	2.06 °C/W
300 ft./min. (1.5m/s)	1.76 °C/W
400 ft./min. (2.0m/s)	1.58 °C/W

**Example with heat sink QBT210 (M-C421):**

What is the minimum airflow necessary for a CQB75W14-72S12 operating at nominal line voltage, an output current of 6.25A, and a maximum ambient temperature of 75°C?

**Solution:**

**Given:**  $V_{in}=72V_{dc}$ ,  $V_o=12V_{dc}$ ,  $I_o=6.25A$

**Determine power dissipation ( $P_d$ ):**  $P_d=P_i-P_o=P_o(1-\eta)/\eta$ ,  $P_d=12 \times 6.25 \times (1-0.88)/0.88=10.23Watts$

**Determine airflow:** Given:  $P_d=10.23W$  and  $T_a=75^\circ C$

**Check above power de-rating curve:** Minimum airflow=100ft./min.

**Verify:**

Maximum temperature rise is  $\Delta T=P_d \times R_{ca}=10.23 \times 2.44=24.9612^\circ C$

Maximum case temperature is  $T_c=T_a+\Delta T=99.9612^\circ C < 105^\circ C$

**Where:**

The  $R_{ca}$  is thermal resistance from case to ambient environment

$T_a$  is ambient temperature and  $T_c$  is case temperature



# CQB75W14 Series Application Note February 2026 V14

## 9.5 Quarter Brick Heat Sinks

Heat sinks assembly [refer to Datasheet-Thermal](#)

## 10. Safety & EMC

### 10.1 Input Fusing and Safety Considerations

The CQB75W14 series converters have no internal fuse. In order to achieve maximum safety and system protection, always use an input line fuse. We recommended a 12A time delay fuse for all models. It is recommended that the circuit have a transient voltage suppressor diode (TVS) across the input terminal to protect the unit against surge or spike voltage and input reverse voltage (as shown).

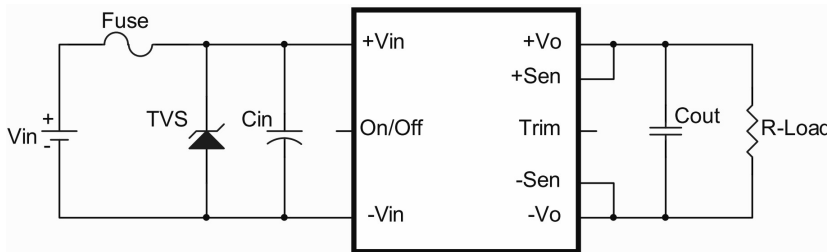

The external input capacitor (Cin) and transient voltage suppressor diode (TVS) are required if CQB75W14 series has to meet EN 61000-4-4, EN 61000-4-5.

The Cin recommended a 220uF/200V (Nippon Chemi-Con KY series) aluminum capacitor. And the TVS recommended a SMCJ180A transient voltage suppressor.

### 10.2 EMC Considerations

EMI Test standard: EN 55032 Class A/EN 50121-3-2:2016 Conducted & Radiated Emission  
Test Condition: Input Voltage: 110V<sub>dc</sub>, Output Load: Full Load

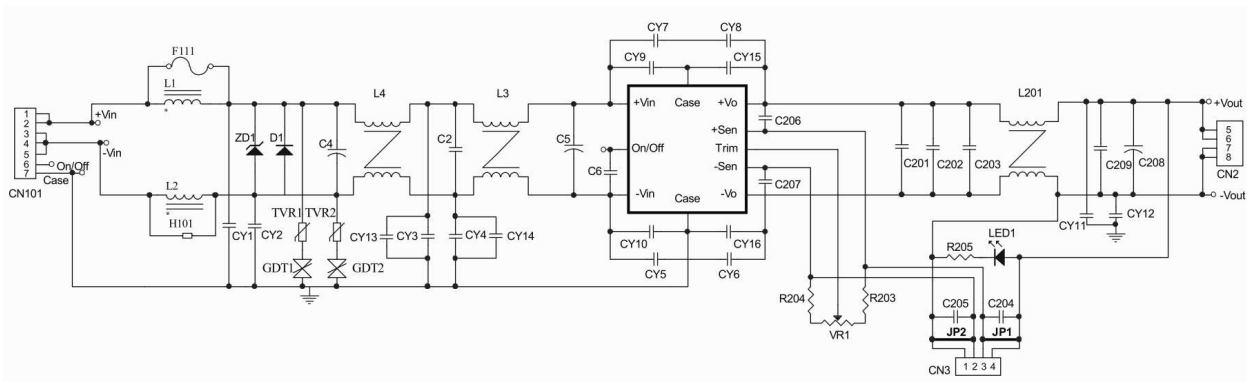

**Figure1 Connection Circuit**





# CQB75W14 Series

## Application Note February 2026 V14

**Components Value:**

Model Name	Model Number					
	72S05	72S12	72S15	72S24	72S28	72S54
C2	1uF/250V SMD					
C4, C5	150uF/200V, Aluminum cap. KXJ series					
C6	4700pF/250V					
C201	47uF/10V SMD	22uF/25V SMD		6.8uF/50V SMD		4.7uF/100V SMD
C202, C203, C209	47uF/16V SMD	10uF/25V SMD		10uF/50V SMD		10uF/100V SMD
CY1	100pF/Y1					
CY2	NC	100pF/Y1		NC		100pF/Y1
CY3	3300pF/Y1	4700pF/Y1				
CY4	4700pF/Y1					
CY5, CY6, CY7, CY8	2200pF/5KV SMD				NC	
CY9	3300pF/Y1	2200pF/Y1				
CY10	NC			3300pF/Y1	1000pF/Y1	
CY11, CY12	0.022uF X2 cap	4700pF/Y1		0.022uF X2 cap		
CY13	100pF/Y1	2200pF/Y1		680pF/Y1	NC	
CY14	100pF/Y1	2200pF/Y1		330pF/Y1	NC	
CY15, CY16	0.022uF X2 cap	4700pF/Y1				0.022uF X2 cap
L1, L2	2.8uH	SHORT				
L3, L4	0.8mm*2/10T 3.88mH~7.53mH TMC20-11-8-A(E) 21.5*9.5*9.5mm COATED TECH MOUNT					
L201	0.8mm*4/4T 0.352mH-0.683mH		0.8mm*2/8T 1.55mH-2.59mH		0.55mm*2/13T 4.1mH-6.8mH	
F111	NC	15A/250V SMD				
Block Pad	NC	1.5*2*10mm conductive copper strip				
CN101	EK500V-07P DINKLE					
CN2	EK500V-04P DINKLE					
CN3	WAFER DIP AC-DC Nylon UL 94V-0 P110I-04 4PIN					
VR1	VR DIP GF063P1-B103 0.5W 10K ±10% TOCOS					
LED1	MS-PT3216ZGSC STONE					
MINI JUMPER	HMJ20-020-95BS (USING IN CN3)					
R203	100R	510R	100R	2K	100R	3.6K
R204	2.49K	1.8K	1.8K	1.8K	2.7K	510R
R205	100K	100K	100K	200K	200K	200K
ZD1	SMCJ180A, LITTELFUSE					
D1	STTH8R03DJF-TR, ST					
GDT1, GDT2	2RK2500M-5-SS, YAGEO					
BEAD CORE	SN030 T2.8*1.7*1.2 SM for CY1, CY9, CY10, CY13, CY14 for CQB7514-72S24					
BEAD CORE	A6B T4*1.5*2 KING CORE CY13, CY14 FOR CQB75W14-72S05, S12, S15					



## CQB75W14 Series

### Application Note February 2026 V14

---

Note:

F111: 0463015.ER LITTELFUSE

C2, C201: 1812 X5/X7R ceramic

C202, C203, C209: 1210 X5R/X7R/X7S ceramic

C6: 0805 X7R ceramic

C4, C5: NIPPON CHEMI-CON KXJ series aluminum capacitor or equivalent

CY1~CY4, CY9~CY10, CY13~CY14: TDK Y1 capacitor or equivalent

CY5~CY8: Safety Capacitors WCAP-CSSA X&Y Safety 2200pF 5kV 2211

CY11, CY12 (05, 24, 28, 54 V<sub>out</sub>): CARLI MPX Series X2 capacitor or HJC MKP Series X2 capacitor or equivalent

CY11, CY12 (12, 15 V<sub>out</sub>): TDK Y1 capacitor or equivalent

CY15, CY16 (05, 28, 54 V<sub>out</sub>): CARLI MPX Series X2 capacitor or equivalent

CY15, CY16 (12, 15, 24 V<sub>out</sub>): TDK Y1 capacitor or equivalent

GDT1, GDT2: Gas Discharge Tube 2RK2500M-5-SS or equivalent

TVR1, TVR2: VARISTOR TVR10471KIC7AV or equivalent

L1, L2: 7443551280 SMD INDUCTOR WURTH or equivalent

L201: FCN0179C WELL LIGHT or equivalent

NC: No connection



# CQB75W14 Series

## Application Note February 2026 V14

### Conducted Emission (Input):

CQB75W14-72S05

Line

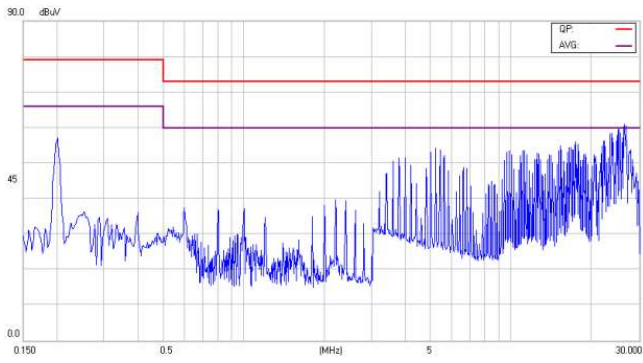

Neutral

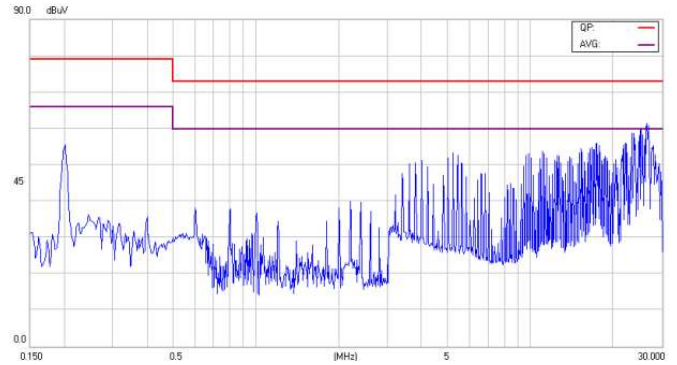

CQB75W14-72S12

Line

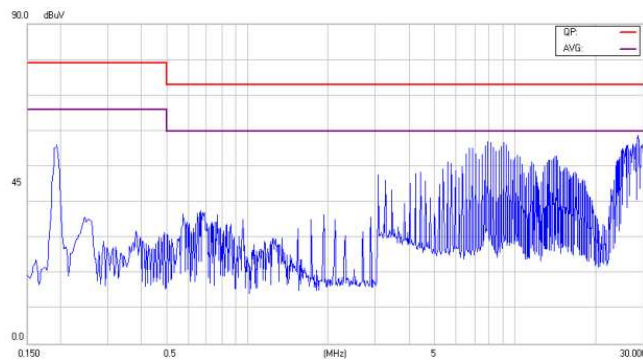

Neutral

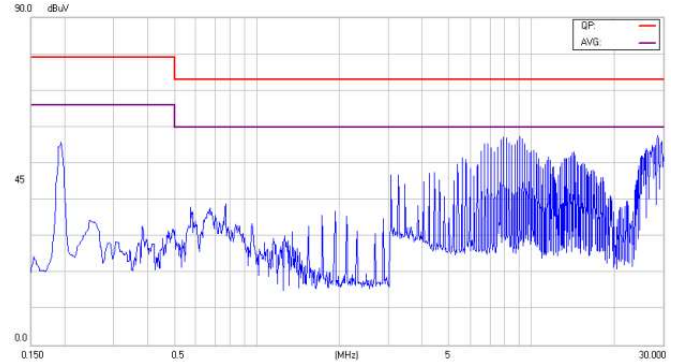

CQB75W14-72S15

Line

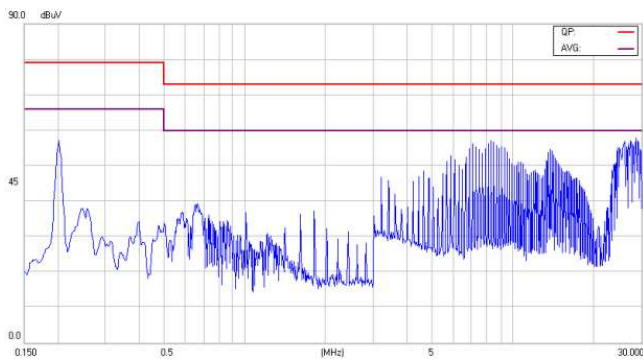

Neutral

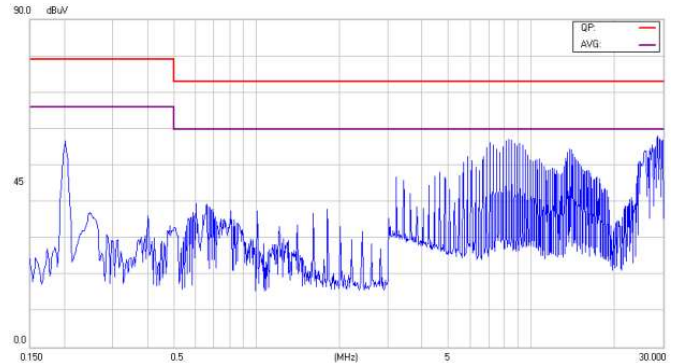



# CQB75W14 Series

## Application Note February 2026 V14

### CQB75W14-72S24

Line

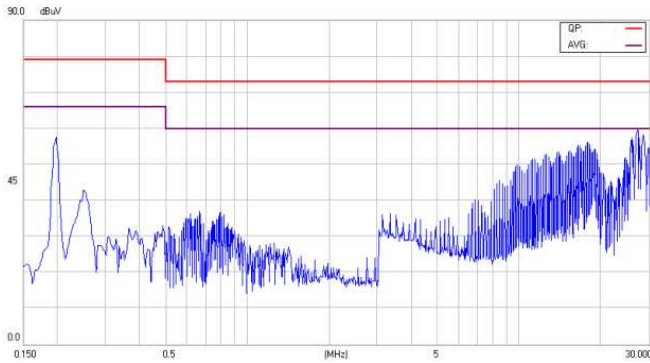

Neutral

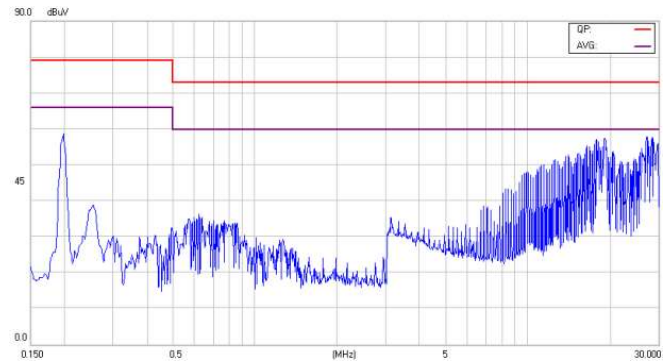

### CQB75W14-72S28

Line

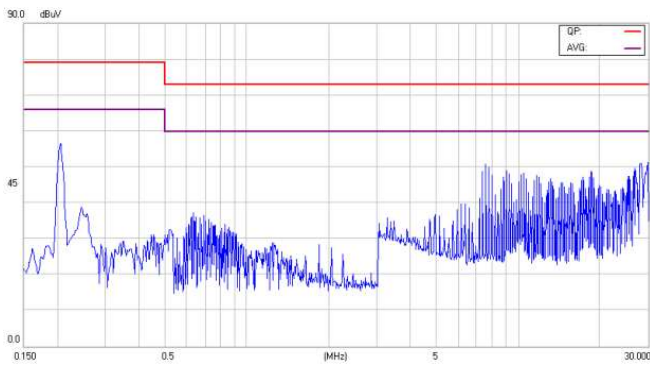

Neutral

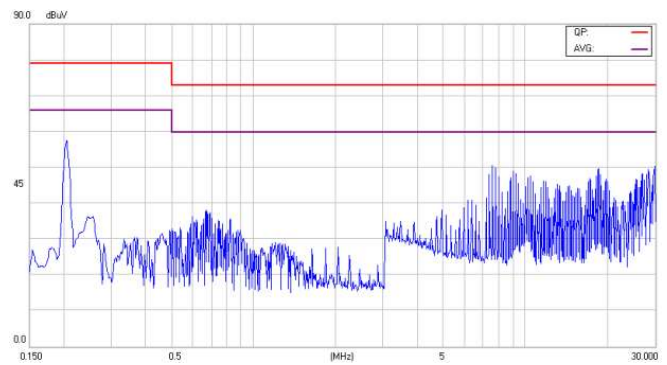

### CQB75W14-72S54

Line

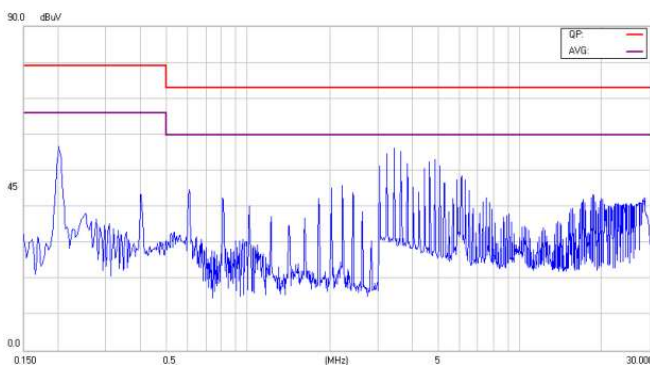

Neutral

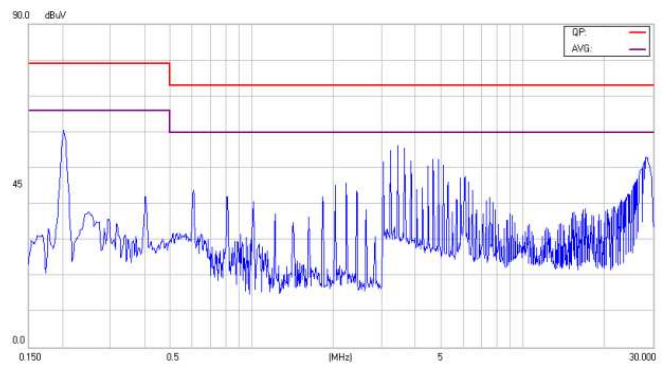



# CQB75W14 Series

## Application Note February 2026 V14

### Conducted Emission (Output):

CQB75W14-72S05

Positive

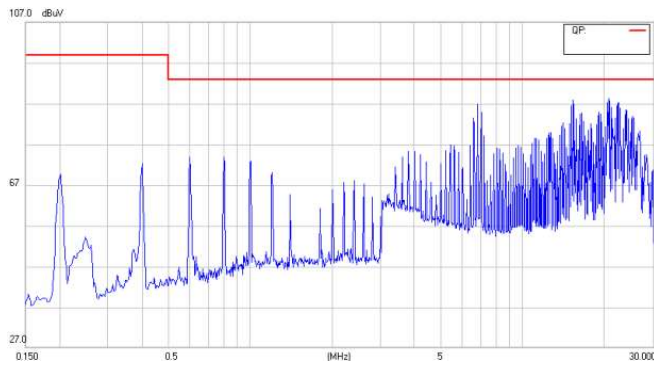

Negative

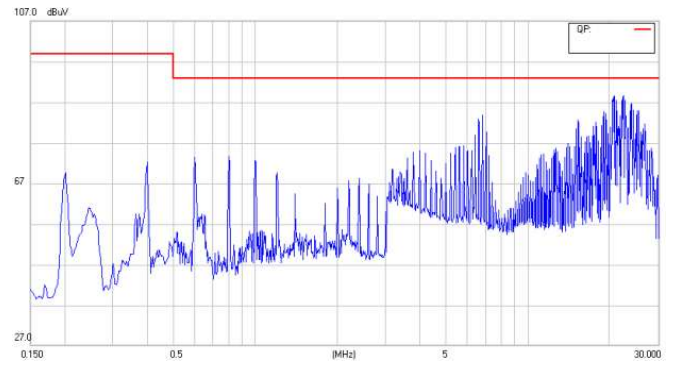

CQB75W14-72S12

Positive

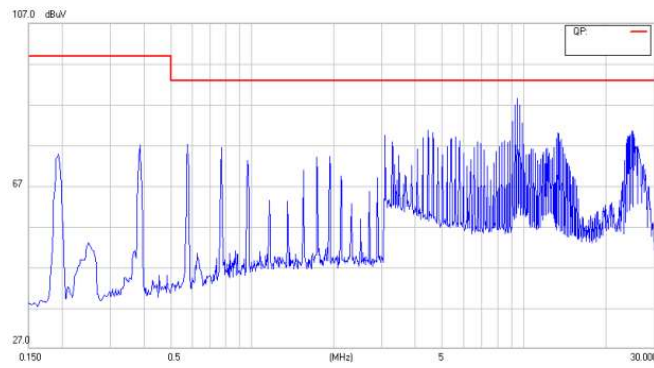

Negative

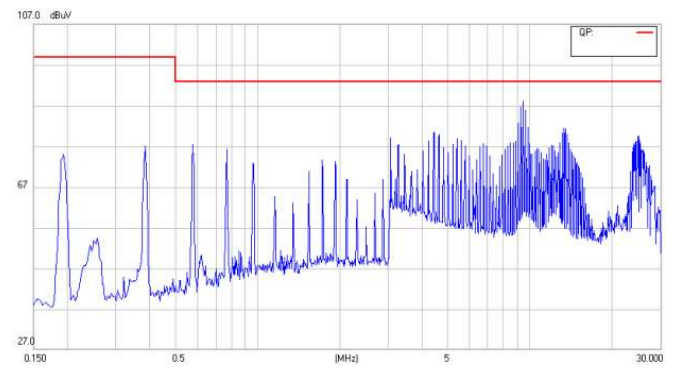

CQB75W14-72S15

Positive

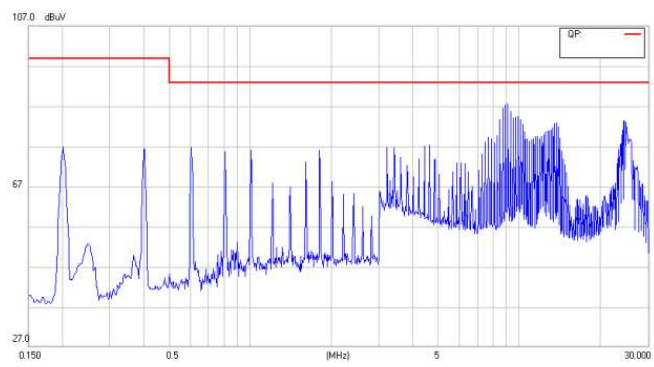

Negative

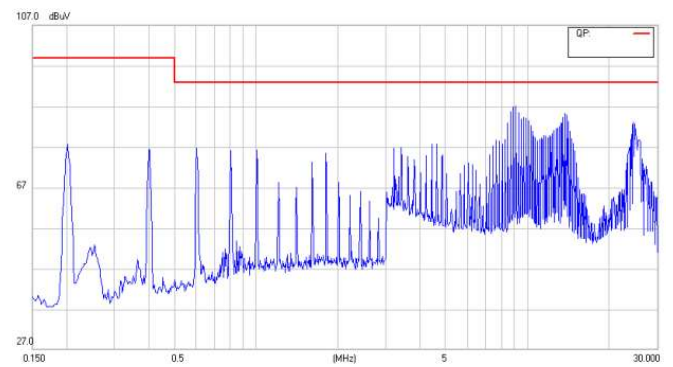



# CQB75W14 Series

## Application Note February 2026 V14

### CQB75W14-72S24

Positive

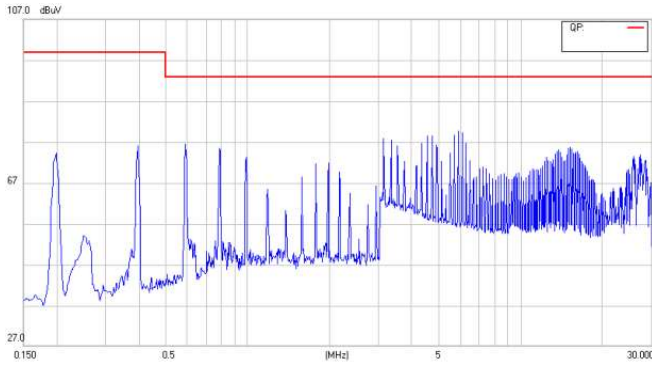

Negative

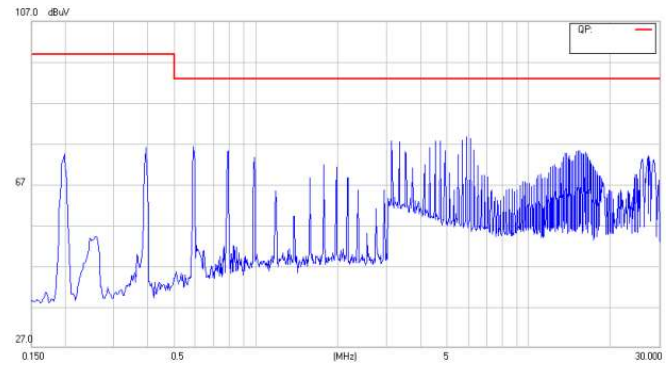

### CQB75W14-72S28

Positive

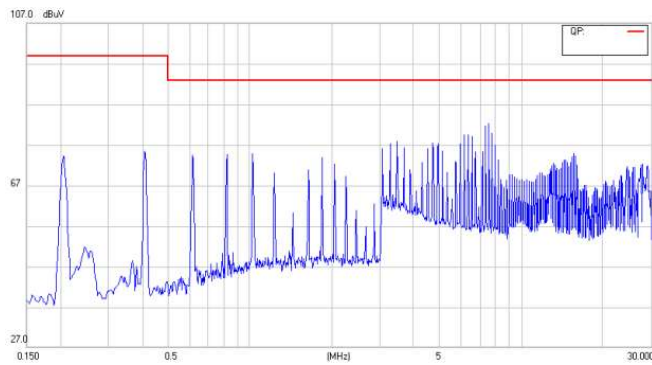

Negative

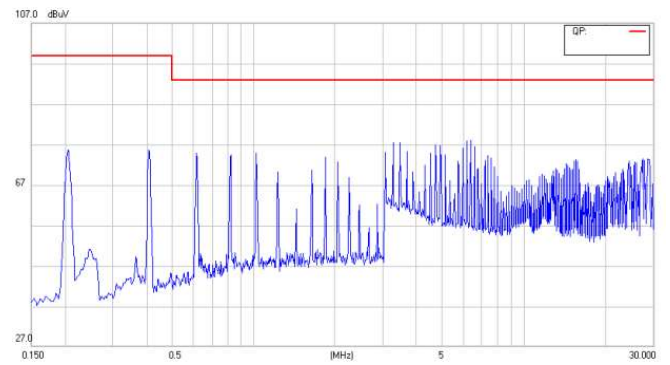

### CQB75W14-72S54

Positive

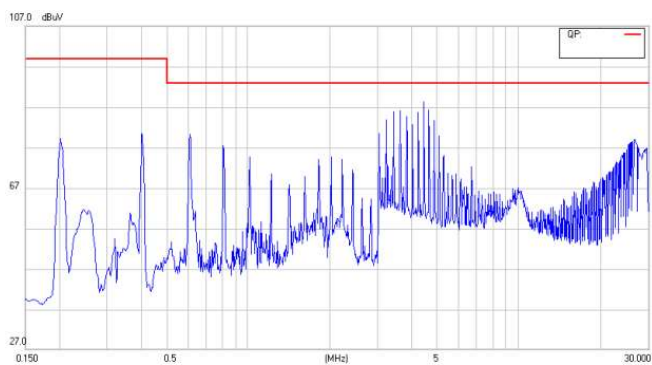

Negative

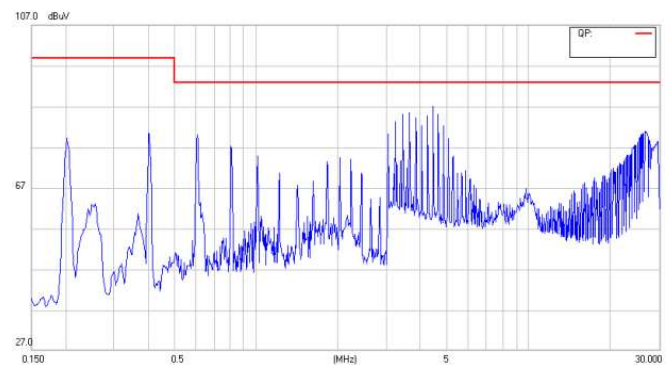



# CQB75W14 Series

## Application Note February 2026 V14

### Radiated Emission:

CQB75W14-72S05

Vertical

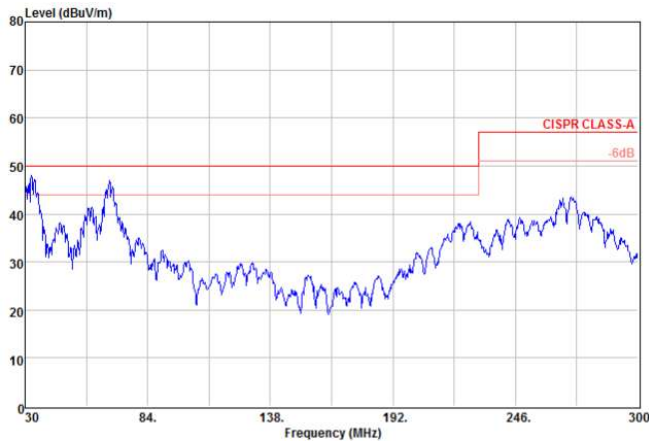

CQB75W14-72S12

Vertical

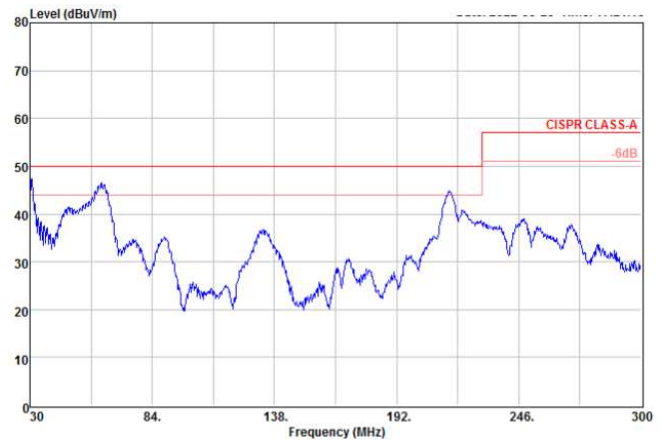

CQB75W14-72S15

Vertical

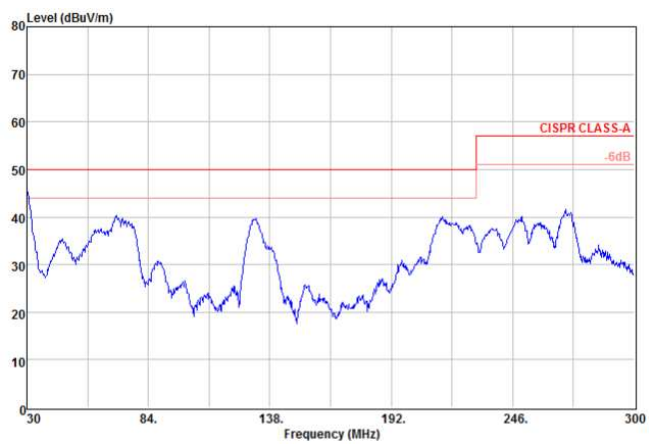

CQB75W14-72S24

Vertical

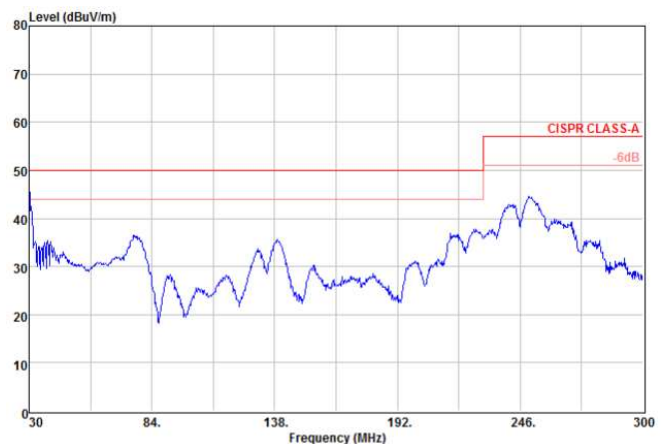

CQB75W14-72S28

Vertical

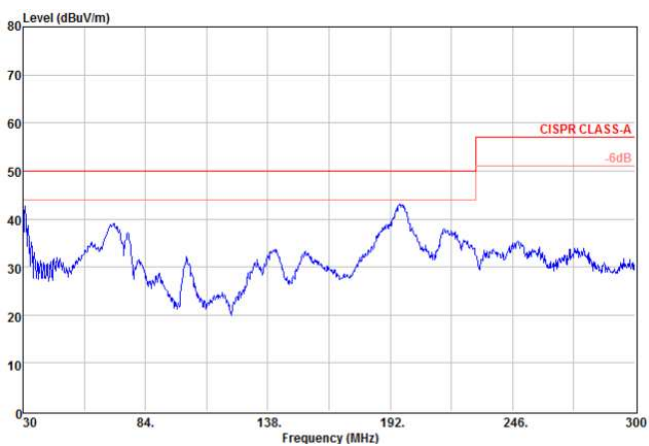

CQB75W14-72S54

Vertical

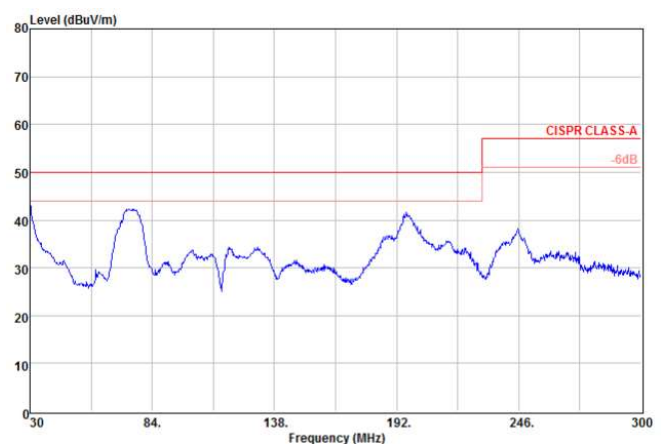



# CQB75W14 Series

## Application Note February 2026 V14

### 10.3 Suggested Configuration for RIA12 Surge Test

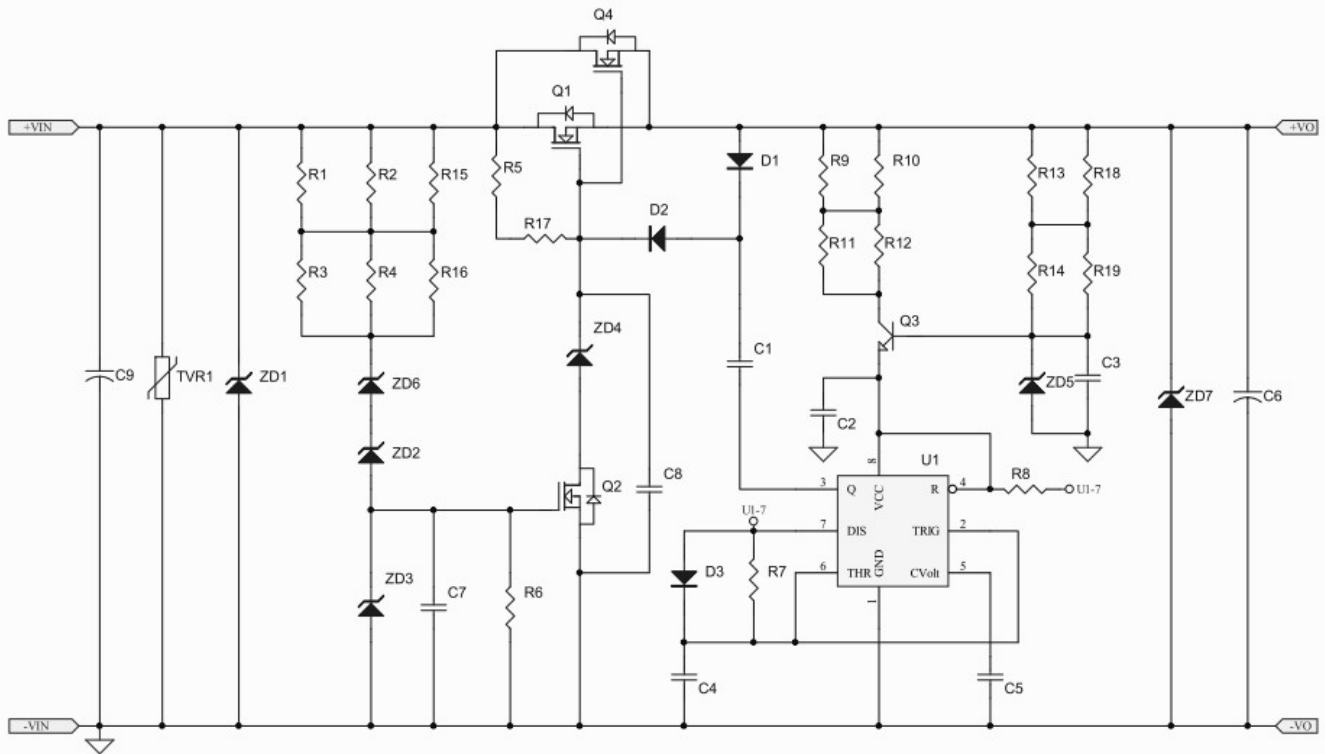

### CINCON ELECTRONICS CO., LTD.

**Headquarters:**

14F, No.306, Sec.4, Hsin Yi Rd.  
 Taipei, Taiwan  
 Tel: 886-2-27086210  
 Fax: 886-2-27029852  
 E-mail: [sales@cincon.com.tw](mailto:sales@cincon.com.tw)  
 Web Site: <https://www.cincon.com>

**Factory:**

No. 8-1, Fu Kung Rd.  
 Fu Hsing Industrial Park  
 Fu Hsing Hsiang,  
 ChangHua Hsien, Taiwan  
 Tel: 886-4-7690261  
 Fax: 886-4-7698031

**Cincon North America:**

1655Mesa Verde Ave. Ste 180  
 Ventura, CA93003  
 Tel: 805-639-3350  
 Fax: 805-639-4101  
 E-mail: [info@cincon.com](mailto:info@cincon.com)