



EC3SA 3W Isolated DC-DC Converters

Application Note V12 December 2016

ISOLATED DC-DC Converter EC3SA SERIES APPLICATION NOTE



Approved By:

Department	Approved By	Checked By	Reported By
Research and Development Department	Enoch	Danny	Joyce
		Jacky	
Quality Assurance Department	Jack	Benny	



EC3SA 3W Isolated DC-DC Converters

Application Note V12 December 2016

Content

1. INTRODUCTION	3
2. DC-DC CONVERTER FEATURES	3
3. ELECTRICAL BLOCK DIAGRAM	3
4. TECHNICAL SPECIFICATIONS	4
5. MAIN FEATURES AND FUNCTIONS	8
5.1 Operating Temperature Range	8
5.2 Over Current Protection	8
5.3 Remote On/Off	8
6. APPLICATIONS	8
6.1 Recommended Layout PCB Footprints and Soldering Information	8
6.2 Power Derating Curves for EC3SA Series	9
6.3 Efficiency vs. Load Curves	10
6.4 Input Capacitance at the Power Module	15
6.7 Test Set-Up	15
6.9 Output Ripple and Noise Measurement	15
6.10 Output Capacitance	15
7. SAFETY & EMC	16
7.1 Input Fusing and Safety Considerations.	16
7.2 EMC Considerations	16
8. PART NUMBER	19
9. MECHANICAL SPECIFICATIONS	19



EC3SA 3W Isolated DC-DC Converters

Application Note V12 December 2016

1. Introduction

The EC3SA series offer 3 watts of output power in a 0.86x0.36x0.44 inches SIL-8 plastic packages. The EC3SA series has a 2:1 wide input voltage range of 4.5-9, 9-18, 18-36 and 36-75VDC and provides a precisely regulated output. This series has features such as high efficiency, 1500VDC of isolation and allows an ambient operating temperature range of -40°C to 71°C without de-rating. The features include short circuit protection and remote on/off control. All models are very suitable for distributed power architectures, telecommunications, battery operated equipment and industrial applications.

2. DC-DC Converter Features

- * 3W Isolated Output
- * Compact SIP-8 Package
- * Efficiency to 86%
- * 2:1 Input Range
- * Regulated Outputs
- * Remote On/Off Control
- * 1500VDC Isolation
- * Continuous Short Circuit Protection

3. Electrical Block Diagram

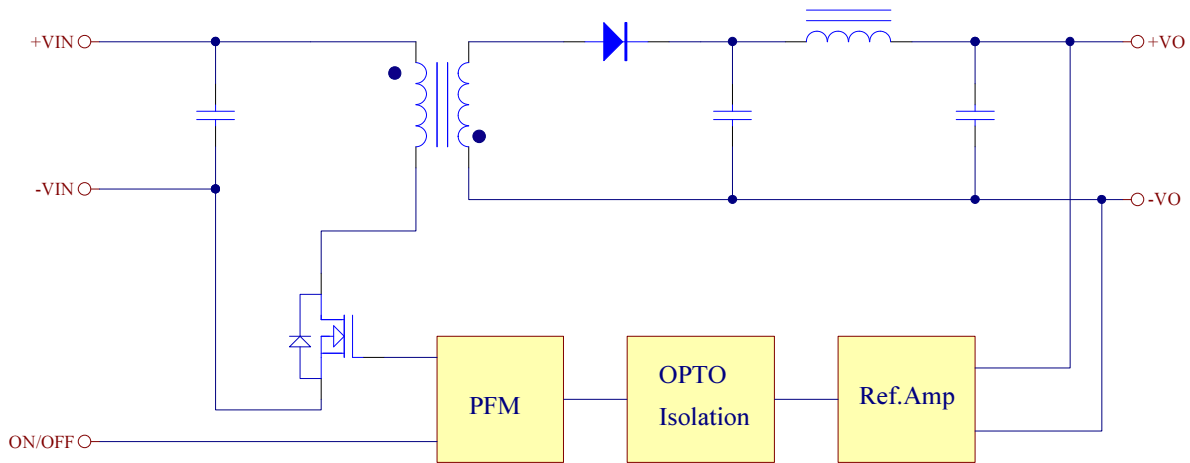

Figure 1 Electrical Block Diagram of single output module

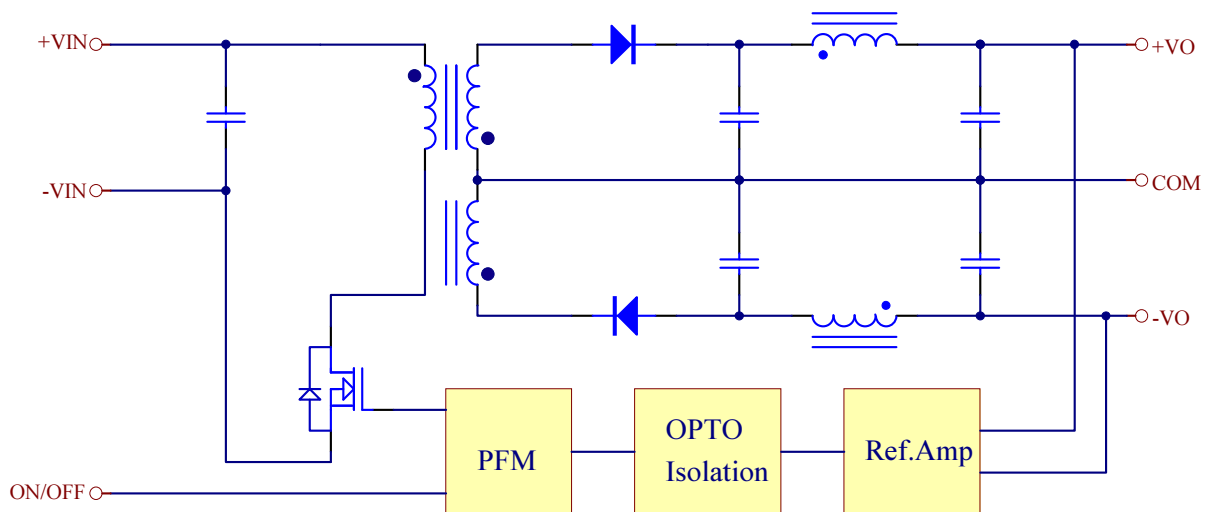

Figure 2 Electrical Block Diagram of dual output module



EC3SA 3W Isolated DC-DC Converters

Application Note V12 December 2016

4. Technical Specifications

(All specifications are typical at nominal input, full load at 25°C unless otherwise noted.)

ABSOLUTE MAXIMUM RATINGS

PARAMETER	NOTES and CONDITIONS	Device	Min.	Typical	Max.	Units
Input Voltage						
Continuous		5V _{in}	-0.3		9	V _{dc}
		12V _{in}	-0.3		18	
		24V _{in}	-0.3		36	
		48V _{in}	-0.3		75	
Transient	100ms	5V _{in}			15	V _{dc}
		12V _{in}			25	
		24V _{in}			50	
		48V _{in}			100	
Operating Ambient Temperature	With de-rating, above 71°C	All	-40		+85	°C
Case Temperature		All			100	°C
Storage Temperature		All	-55		+125	°C
Input/Output Isolation Voltage	1 minute	All	1500			V _{dc}

INPUT CHARACTERISTICS

PARAMETER	NOTES and CONDITIONS	Device	Min.	Typical	Max.	Units
Operating Input Voltage		5V _{in}	4.5	5	9	V _{dc}
		12V _{in}	9	12	18	
		24V _{in}	18	24	36	
		48V _{in}	36	48	75	
Input Under-Voltage Protection Only For Suffix "N" Model						
Turn-On Voltage Threshold		5V _{in}	3.3		4.2	V _{dc}
		12V _{in}	6.8		7.3	
		24V _{in}	13		15.5	
		48V _{in}	26		31	
Turn-Off Voltage Threshold		5V _{in}	3		3.9	V _{dc}
		12V _{in}	5.8		6.3	
		24V _{in}	12		14.5	
		48V _{in}	24		29	
Lockout Hysteresis Voltage		5V _{in}		0.3		V _{dc}
		12V _{in}		0.5		
		24V _{in}		1		
		48V _{in}		2		
Maximum Input Current	100% Load, V _{in} =4.5V	5V _{in}		890		mA
	100% Load, V _{in} =9V	12V _{in}		440		
	100% Load, V _{in} =18V	24V _{in}		220		
	100% Load, V _{in} =36V	48V _{in}		110		
No-Load Input Current	V _{in} =Nominal input	5V _{in}		60		mA
		12V _{in}		30		
		24V _{in}		18		
		48V _{in}		9		



EC3SA 3W Isolated DC-DC Converters

Application Note V12 December 2016

PARAMETER	NOTES and CONDITIONS	Device	Min.	Typical	Max.	Units
Off Converter Input Current	Shutdown input idle current	All			1	mA
Inrush Current (I^2t)		All			0.01	A ² s
Input Reflected-Ripple Current	P-P thru 12uH inductor, 5Hz to 20MHz	All		30		mA

OUTPUT CHARACTERISTIC

PARAMETER	NOTES and CONDITIONS	Device	Min.	Typical	Max.	Units
Output Voltage Set Point	V_{in} nominal, $I_o=I_{o_{max}}$, $T_c=25^\circ C$	$V_o=3.3V$	3.2505	3.3	3.3495	V_{dc}
		$V_o=5.0V$	4.925	5.0	5.075	
		$V_o=12V$	11.82	12	12.18	
		$V_o=15V$	14.775	15	15.225	
		$V_o=\pm 5V$	± 4.925	± 5.0	± 5.075	
		$V_o=\pm 12V$	± 11.82	± 12	± 12.18	
		$V_o=\pm 15V$	± 14.775	± 15	± 15.225	
Output Voltage Balance	V_{in} =nominal, $I_o=I_{o_{max}}$, $T_c=25^\circ C$	Dual			± 1.0	%
Output Voltage Regulation						
Load Regulation	I_o =Full Load to 10% Load	Single			± 0.5	%
	I_o =Full Load to 10% Load	Dual			± 1.0	
Line Regulation	V_{in} =High line to Low line Full Load	All			± 0.5	%
Cross Regulation	Asymmetrical Load 25%/100%	Dual			± 5	%
Temperature Coefficient	$T_a=-40^\circ C$ to $85^\circ C$	All			± 0.03	%/ $^\circ C$
Output Voltage Ripple and Noise						
Peak-to-Peak	Full Load, 20MHz bandwidth	All			75	mV
Operating Output Current Range	Full load, Resistance	$V_o=3.3V$	0		700	mA
		$V_o=5.0V$	0		600	
		$V_o=12V$	0		250	
		$V_o=15V$	0		200	
		$V_o=\pm 5V$	0		± 300	
		$V_o=\pm 12V$	0		± 125	
		$V_o=\pm 15V$	0		± 100	
Output DC Current-Limit Inception	Output Voltage =90% $V_{o_{nominal}}$		120			%
Maximum Output Capacitance	Full load, Resistance	$V_o=3.3V$	0		700	uF
		$V_o=5.0V$	0		600	
		$V_o=12V$	0		250	
		$V_o=15V$	0		200	
		$V_o=\pm 5V$	0		300	
		$V_o=\pm 12V$	0		125	
		$V_o=\pm 15V$	0		100	

DYNAMIC CHARACTERISTICS

PARAMETER	NOTES and CONDITIONS	Device	Min.	Typical	Max.	Units
Output Voltage Current Transient						
Step Change in Output Current	75% to 100% $I_{o_{max}}$, $di/dt=0.1A/us$	All			± 6	%
Setting Time (within 1% $V_{o_{nominal}}$)	$di/dt=0.1A/us$	All			500	us



EC3SA 3W Isolated DC-DC Converters

Application Note V12 December 2016

PARAMETER	NOTES and CONDITIONS	Device	Min.	Typical	Max.	Units
Turn-On Delay and Rise Time						
Turn-On Delay Time, From Input	$V_{in_{min}}$ to 10% $V_{O_{nominal}}$	All		1		ms
Turn-On Delay Time, From On/off	$V_{on/off}$ to 10% $V_{O_{nominal}}$	All		1		ms
Output Voltage Rise Time	10% to 90% $V_{O_{nominal}}$	All		2.5		ms

EFFICIENCY

PARAMETER	NOTES and CONDITIONS	Device	Min.	Typical	Max.	Units
100% Load	$V_{in}=5V$	$V_o=3.3V$		73		%
		$V_o=5.0V$		78		
		$V_o=12V$		81		
		$V_o=15V$		81		
		$V_o=\pm 5V$		78		
		$V_o=\pm 12V$		81		
	$V_{in}=12V$	$V_o=3.3V$		76		
		$V_o=5.0V$		81		
		$V_o=12V$		83		
		$V_o=15V$		84		
		$V_o=\pm 5V$		82		
		$V_o=\pm 12V$		83		
$V_{in}=24V$	$V_o=3.3V$		77			
	$V_o=5.0V$		81			
	$V_o=12V$		84			
	$V_o=15V$		85			
	$V_o=\pm 5V$		80			
	$V_o=\pm 12V$		84			
$V_{in}=48V$	$V_o=3.3V$		77			
	$V_o=5.0V$		81			
	$V_o=12V$		86			
	$V_o=15V$		86			
	$V_o=\pm 5V$		81			
	$V_o=\pm 12V$		86			
	$V_o=\pm 15V$		86			

ISOLATION CHARACTERISTICS

PARAMETER	NOTES and CONDITIONS	Device	Min.	Typical	Max.	Units
Isolation Voltage	Input to Output 1 minute	All			1500	V_{dc}
Isolation Resistance	Input to Output	All			1000	$M\Omega$
Isolation Capacitance	Input to Output	All		500		pF



EC3SA 3W Isolated DC-DC Converters

Application Note V12 December 2016

FEATURE CHARACTERISTICS

PARAMETER	NOTES and CONDITIONS	Device	Min.	Typical	Max.	Units
Switching Frequency		All	100			KHz
On/Off Control						
Module On	Open ,high impedance or <1.2V	All	0		1.2 or Open Circuit	V
Module Off	Voltage of $V_{on/off}$ pin	All	5.5		15	V
On/Off Control Only For Suffix "N" Model						
Module On	Open ,high impedance or <0.8V	All	0		0.8 or Open Circuit	V
Module Off	Voltage of $V_{on/off}$ pin	All	4		15	V
Off Converter Input Current	Shutdown input idle current	All			1	mA

GENERAL SPECIFICATIONS

PARAMETER	NOTES and CONDITIONS	Device	Min.	Typical	Max.	Units
MTBF	$I_o=100\%$ of $I_{o,max.}$, per MIL-HDBK-217F_Notice 1, GB 25°C	All		2500		K hours
Weight		All		4.8		g



EC3SA 3W Isolated DC-DC Converters

Application Note V12 December 2016

5. Main Features and Functions

5.1 Operating Temperature Range

The EC3SA series converters can be operated by a wide ambient temperature range from -40°C to 71°C without de-rating. The standard model has a plastic case and case temperature can not over 100°C at normal operating.

5.2 Over Current Protection

All different voltage models have full continuous short-circuit protection. To provide protection in a fault condition, the unit is equipped with internal over-current protection. The unit operates normally once the fault condition is removed. At the point of current-limit inception, the converter will go into over current protection mode.

5.3 Remote On/Off

The remote on/off input feature of the converter allows external circuitry to turn the converter on or off. Active-high remote on/off is available as standard. The converter is turned on if the remote on/off pin is high impedance or open circuit. Suffix "N" to the Model Number with the remote on/off pin at 4 to 15Vdc will turn the converter off, other models at 5.5 to 15Vdc. The signal level of the on/off pin is defined with respect to ground. If not using the on/off pin, leave the pin open (module will be on).

6. Applications

6.1 Recommended Layout PCB Footprints and Soldering Information

The system designer or the end user must ensure that other components and metal in the vicinity of the converter meet the spacing requirements to which the system is approved. Low resistance and low inductance PCB layout traces are the norm and should be used where possible. Due consideration must also be given to proper low impedance tracks between power module, input and output grounds. The recommended footprints and soldering profiles are shown as Figure 3.

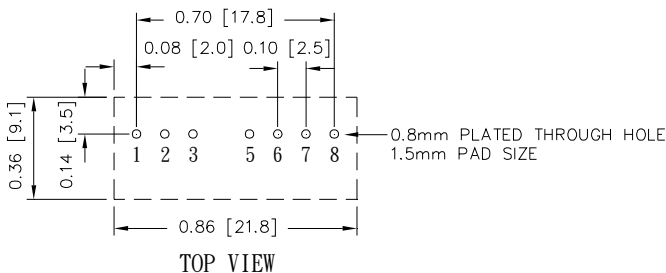

Note: Dimensions are in inches(millimeters)

Lead Free Wave Soldering Profile

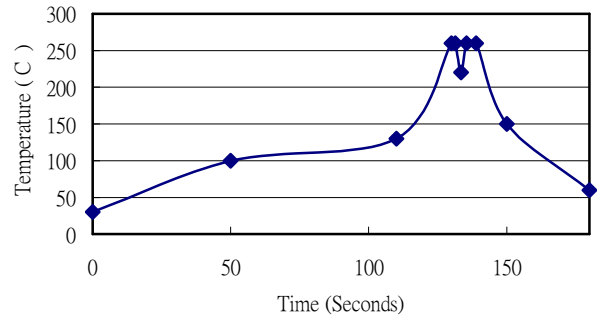

Note :

1. Soldering Materials: Sn/Cu/Ni
2. Ramp up rate during preheat: $1.4^{\circ}\text{C}/\text{Sec}$
(From 50°C to 100°C)
3. Soaking temperature: $0.5^{\circ}\text{C}/\text{Sec}$
(From 100°C to 130°C), 60 ± 20 seconds
4. Peak temperature: 260°C , above 250°C 3~6 Seconds
5. Ramp up rate during cooling : $-10.0^{\circ}\text{C}/\text{Sec}$
(From 260°C to 150°C)

Figure3 Recommended PCB Layout Footprints and Wave Soldering Profiles for SIL packages



EC3SA 3W Isolated DC-DC Converters

Application Note V12 December 2016

6.2 Power Derating Curves for EC3SA Series

Operating Ambient temperature Range: $-40^{\circ}\text{C} \sim 71^{\circ}\text{C}$ without derating.

Maximum case temperature under any operating condition should not exceed 100°C .

Typical Derating Curve for Natural Convection

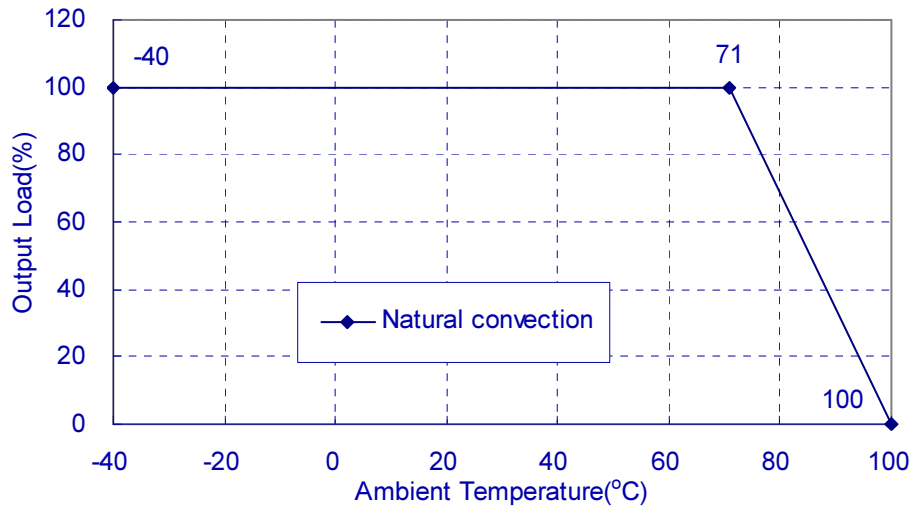



EC3SA 3W Isolated DC-DC Converters

Application Note V12 December 2016

6.3 Efficiency vs. Load Curves

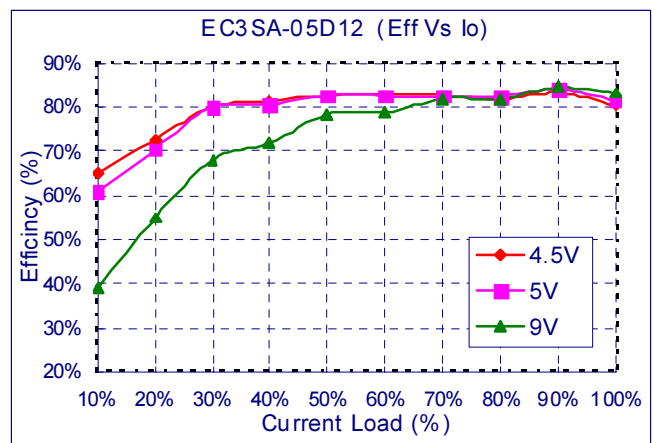
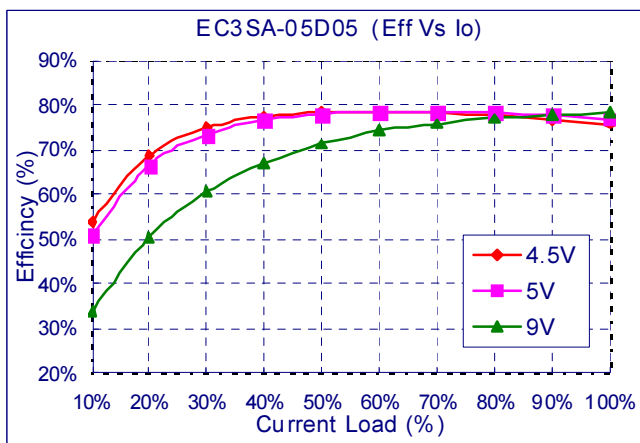
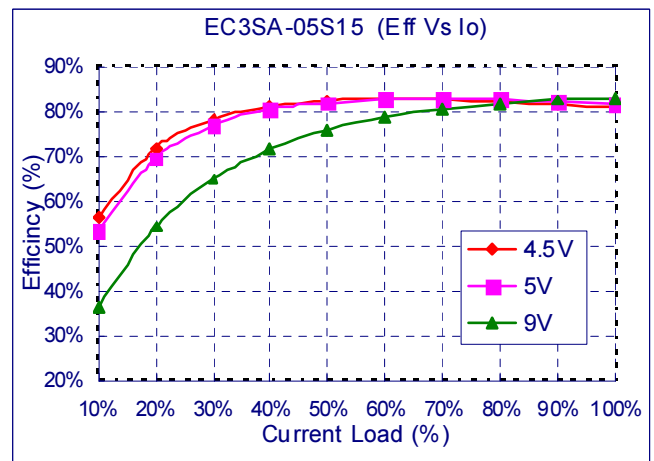
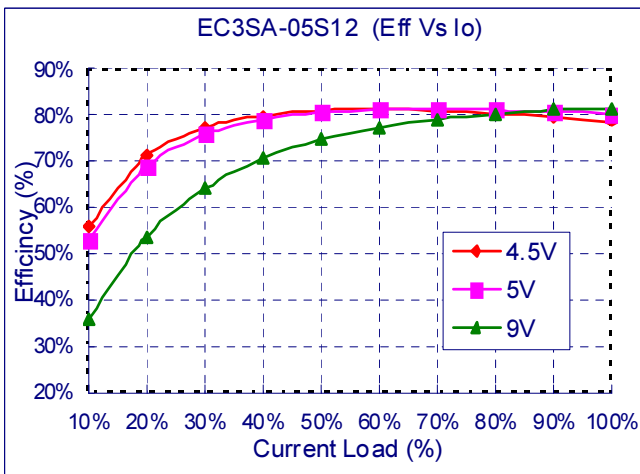
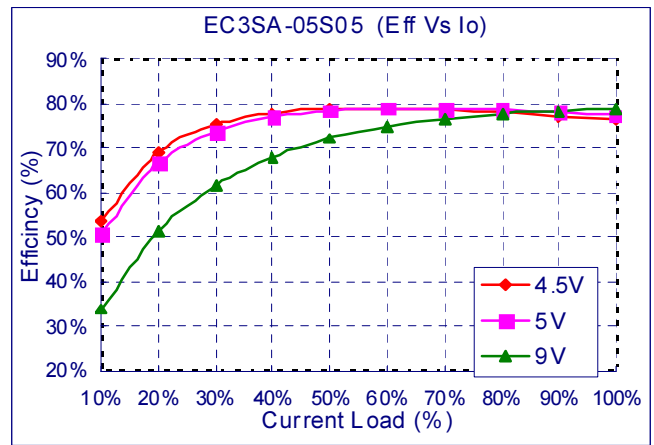
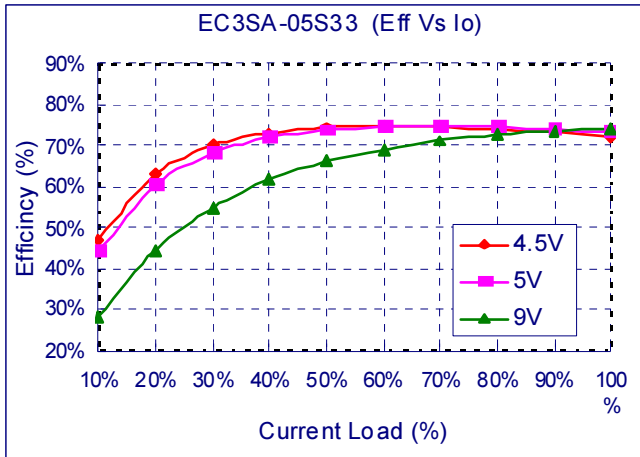



EC3SA 3W Isolated DC-DC Converters

Application Note V12 December 2016

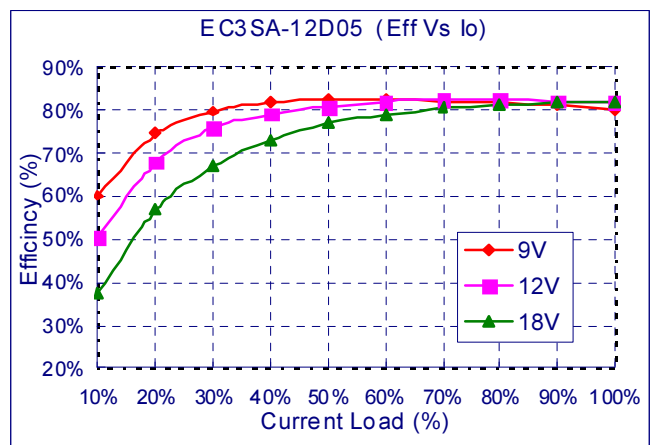
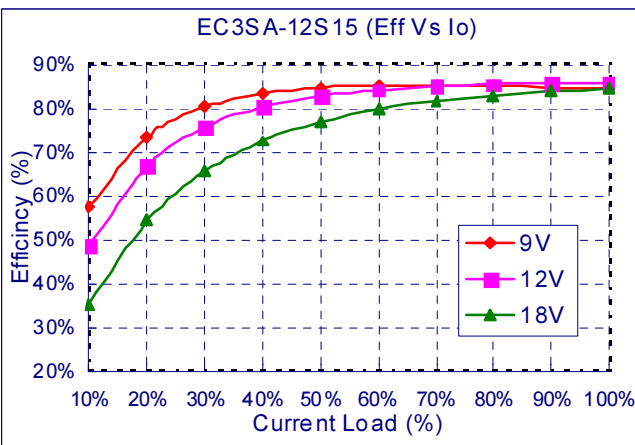
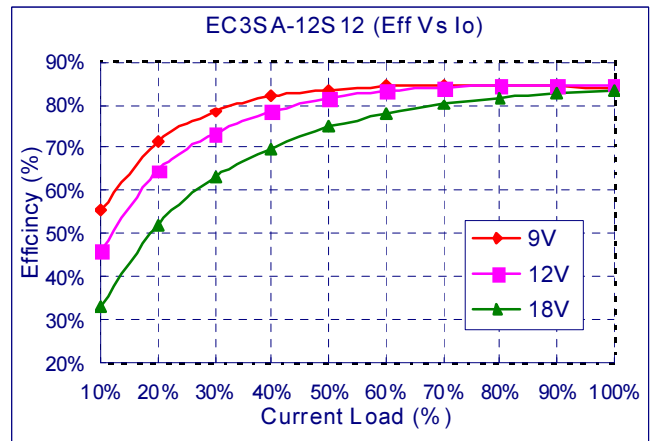
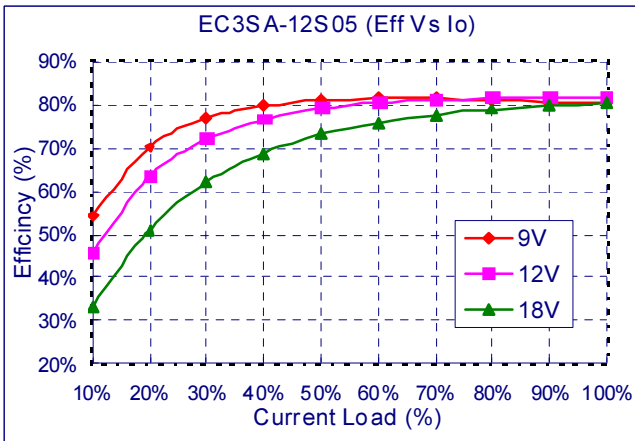
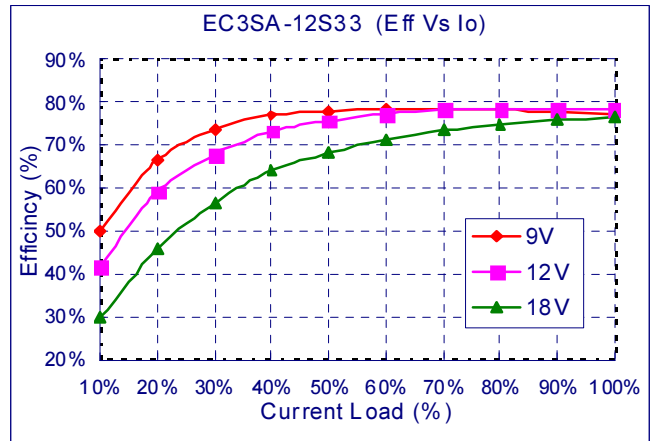
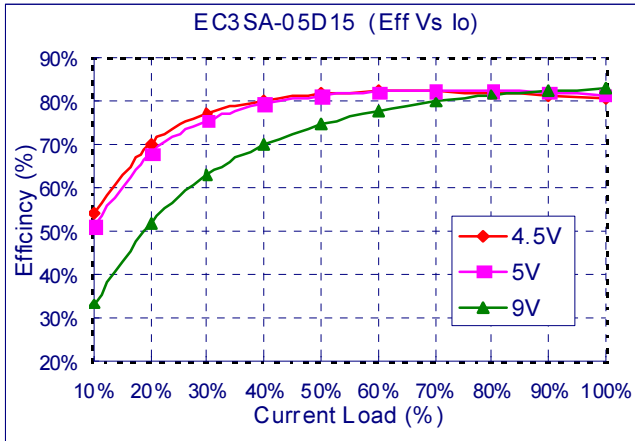



EC3SA 3W Isolated DC-DC Converters

Application Note V12 December 2016

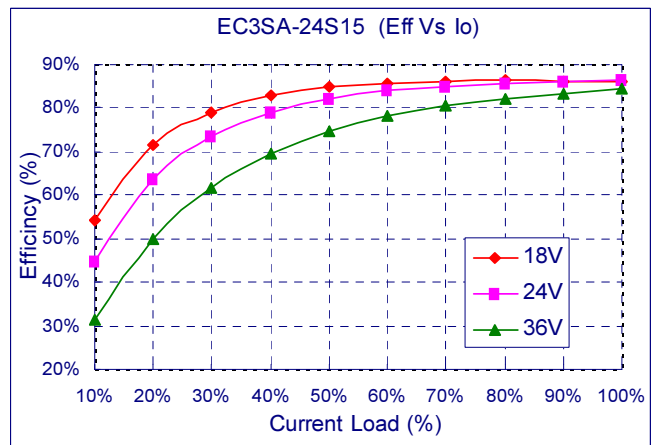
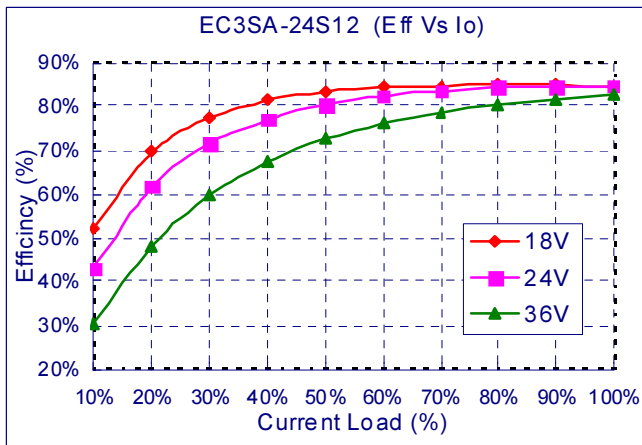
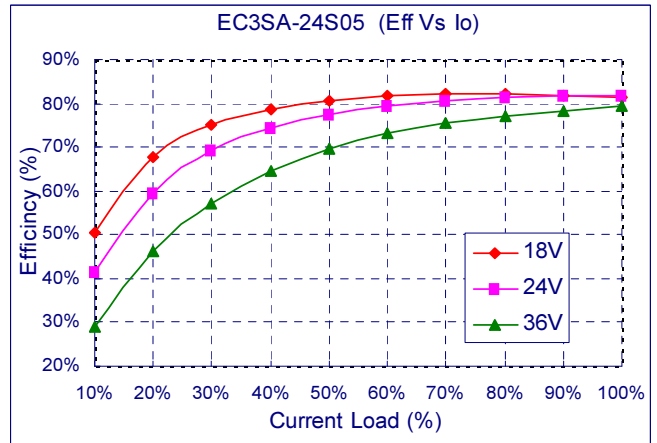
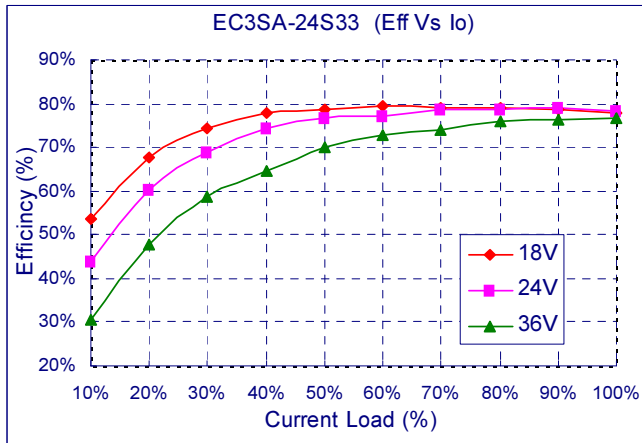
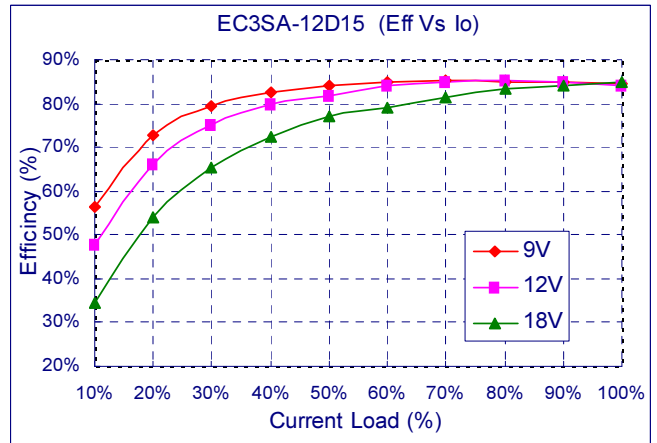
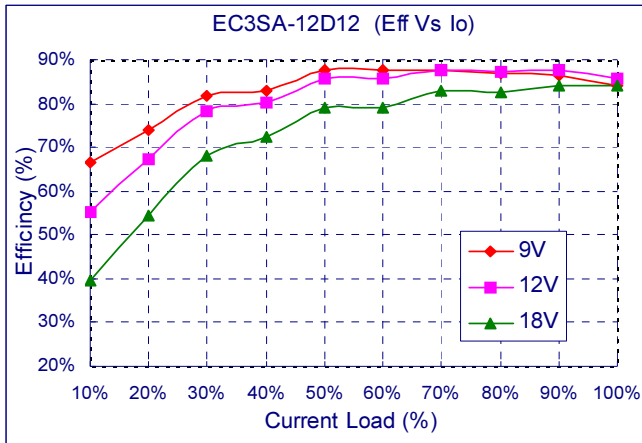



EC3SA 3W Isolated DC-DC Converters

Application Note V12 December 2016

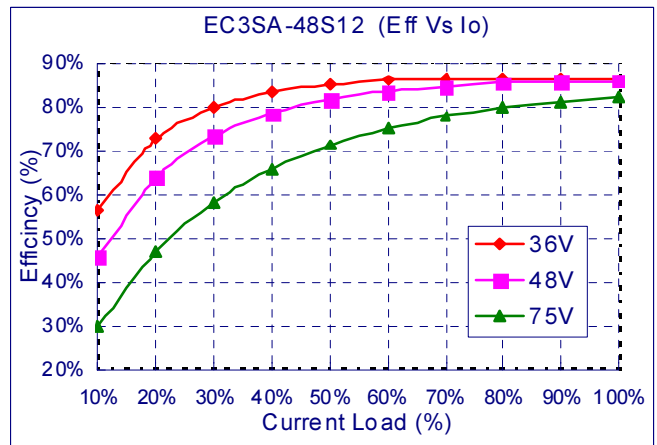
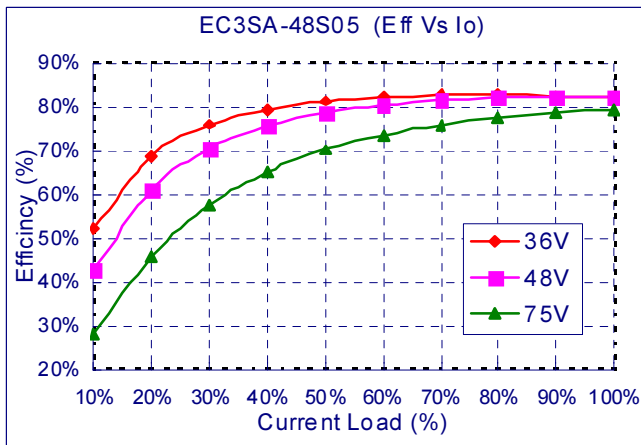
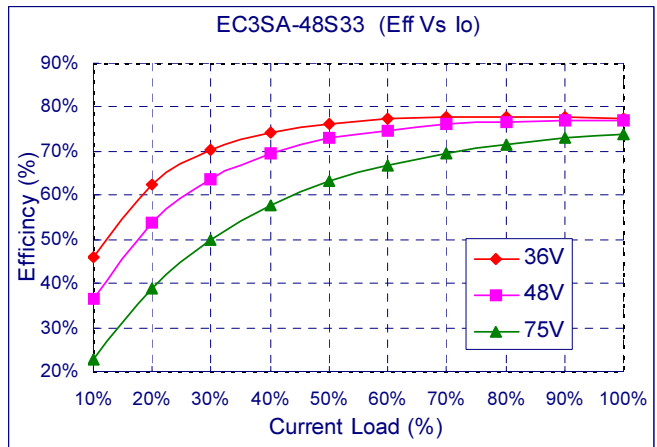
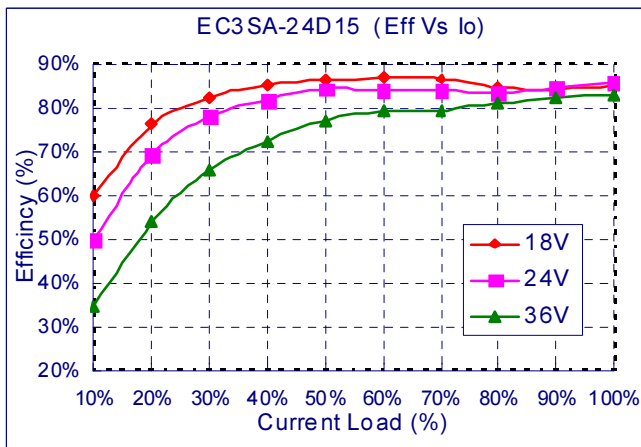
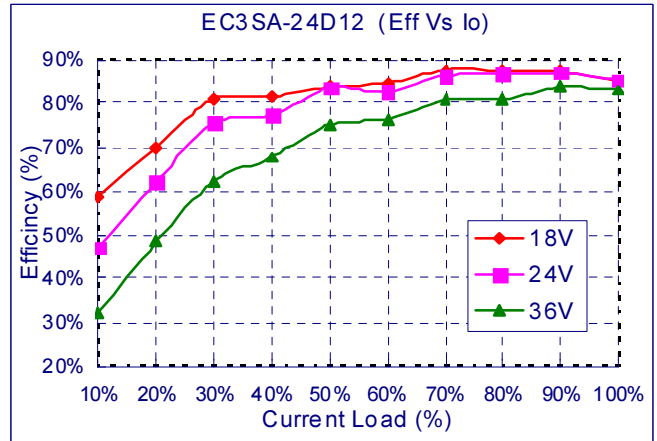
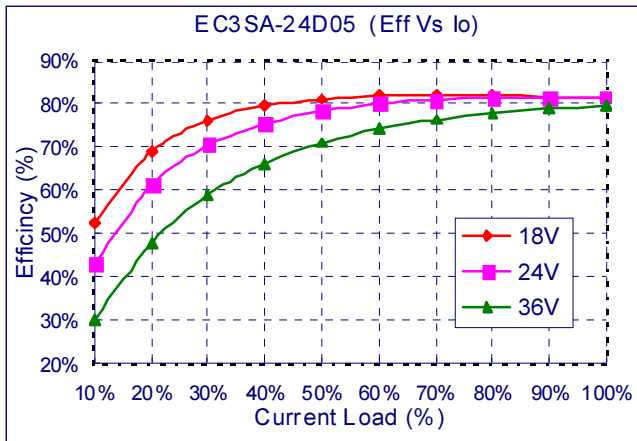



EC3SA 3W Isolated DC-DC Converters

Application Note V12 December 2016

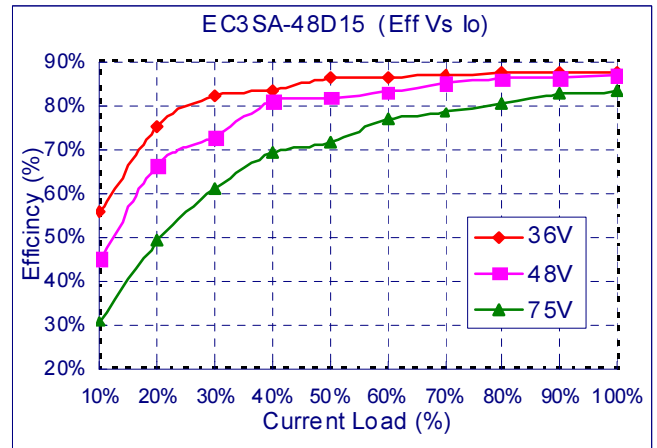
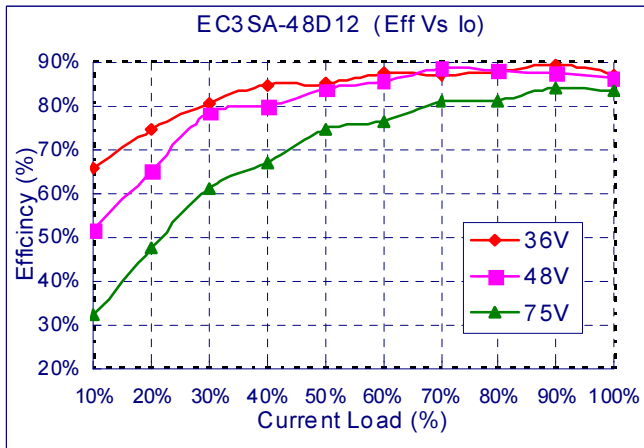
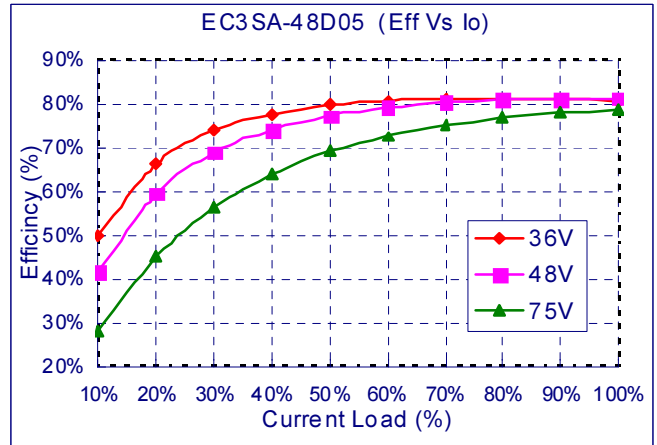
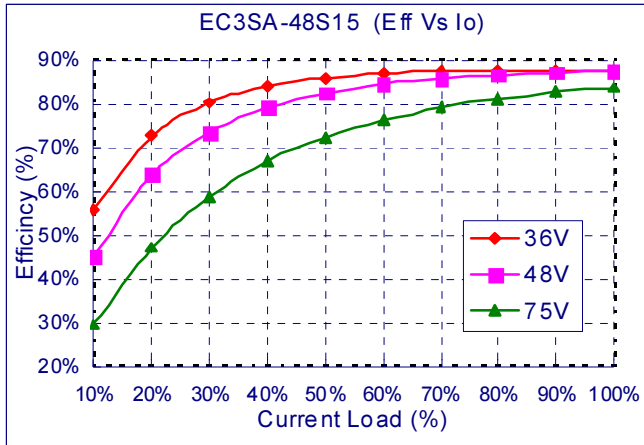



EC3SA 3W Isolated DC-DC Converters

Application Note V12 December 2016

6.4 Input Capacitance at the Power Module

The converters must be connected to low AC source impedance. To avoid problems with loop stability source inductance should be low. Also, the input capacitors (Cin) should be placed close to the converter input pins to de-couple distribution inductance. However, the external input capacitors are chosen for suitable ripple handling capability. Low ESR capacitors are good choice. Circuit as shown in Figure4 represents typical measurement methods for reflected ripple current. C1 and L1 simulate a typical DC source impedance. The input reflected-ripple current is measured by current probe to oscilloscope with a simulated source Inductance (L1).

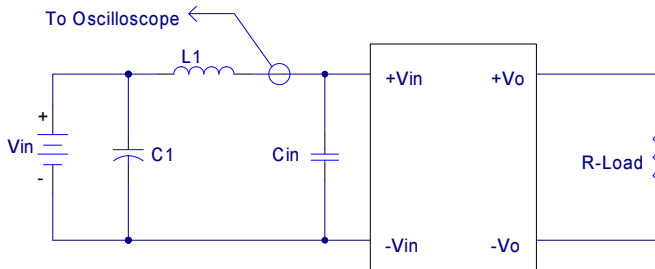

L1: 12uF
 C1: None
 Cin: 33uF ESR<0.7ohm @100KHz

Figure4 Input Reflected-Ripple Test Setup

6.7 Test Set-Up

The basic test set-up to measure parameters such as efficiency and load regulation is shown in Figure5. When testing the modules under any transient conditions please ensure that the transient response of the source is sufficient to power the equipment under test. We can calculate the

- Efficiency
- Load regulation and line regulation.

The value of efficiency is defined as:

$$\eta = \frac{V_o \times I_o}{V_{in} \times I_{in}} \times 100\%$$

Where

Vo is output voltage,
 Io is output current,
 Vin is input voltage,
 Iin is input current.

The value of load regulation is defined as:

$$Load.reg = \frac{V_{FL} - V_{NL}}{V_{NL}} \times 100\%$$

Where

V_{FL} is the output voltage at full load
 V_{NL} is the output voltage at 10% load

The value of line regulation is defined as:

$$Line.reg = \frac{V_{HL} - V_{LL}}{V_{LL}} \times 100\%$$

Where: V_{HL} is the output voltage of maximum input voltage at full load. V_{LL} is the output voltage of minimum input voltage at full load.

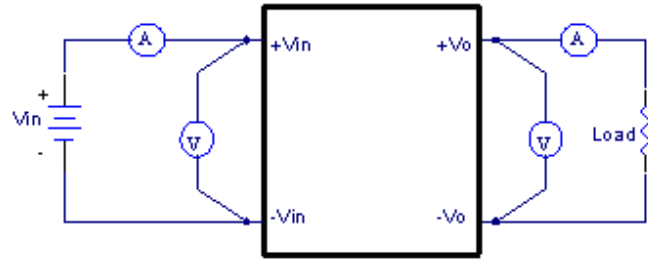
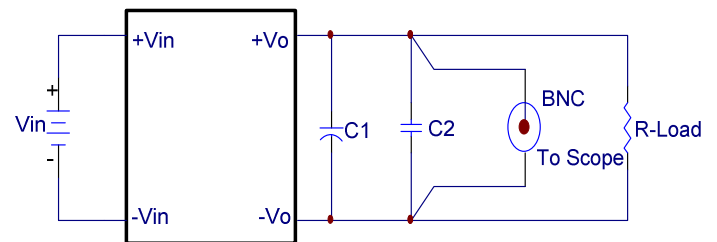

Figure5 EC3SA Series Test Setup

6.9 Output Ripple and Noise Measurement

The test set-up for noise and ripple measurements is shown in Figure6. A coaxial cable was used to prevent impedance mismatch reflections disturbing the noise readings at higher frequencies. Measurements are taken with output appropriately loaded and all ripple/noise specifications are from D.C. to 20MHz Band Width.



Note: C1: None
 C2: None

Figure6 Output Voltage Ripple and Noise Measurement Set-Up

6.10 Output Capacitance

The EC3SA series converters provide unconditional stability with or without external capacitors. For good transient response low ESR output capacitors should be located close to the point of load. These series converters are designed to work with load capacitance to see technical specifications.



7. Safety & EMC

7.1 Input Fusing and Safety Considerations.

The EC3SA series converters have not an internal fuse. However, to achieve maximum safety and system protection, always use an input line fuse. We recommended a fast acting fuse 2A for 5Vin models, 1A for 12Vin models and 500mA for 24Vin and 48Vin modules. Figure7 circuit is recommended by a Transient Voltage Suppressor diode across the input terminal to protect the unit against surge or spike voltage and input reverse voltage.

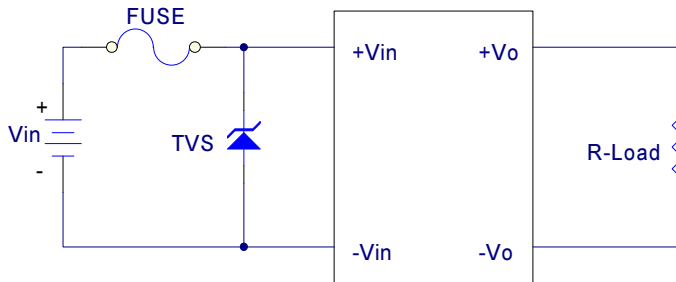

Figure7 Input Protection

7.2 EMC Considerations

EMI Test standard: EN55022 Class A and Class B Conducted Emission

Test Condition: Input Voltage: Nominal, Output Load: Full Load

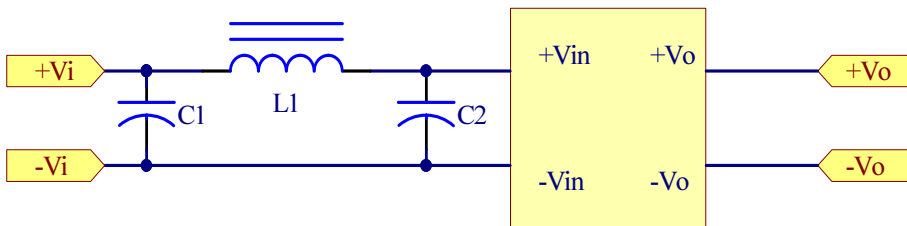

Figure8 Connection circuit for conducted EMI testing



EC3SA 3W Isolated DC-DC Converters

Application Note V12 December 2016

Model No.	EN55022 class A			EN55022 class B		
	C1	C2	L1	C1	C2	L1
EC3SA-05S33	10uF/16V 1206	NC	2.2uH	10uF/25V 1210	NC	10uH
EC3SA-05S05	10uF/16V 1206	NC	2.2uH	10uF/25V 1210	NC	10uH
EC3SA-05S12	10uF/16V 1206	NC	2.2uH	10uF/25V 1210	NC	10uH
EC3SA-05S15	10uF/16V 1206	NC	2.2uH	10uF/25V 1210	NC	10uH
EC3SA-05D05	10uF/16V 1206	NC	2.2uH	10uF/25V 1210	NC	10uH
EC3SA-05D12	10uF/16V 1206	NC	2.2uH	10uF/25V 1210	NC	10uH
EC3SA-05D15	10uF/16V 1206	NC	2.2uH	10uF/25V 1210	NC	10uH
EC3SA-12S33	2.2uF/25V 1206	NC	12uH	2.2uF/25V 1210	NC	33uH
EC3SA-12S05	2.2uF/25V 1206	NC	12uH	2.2uF/25V 1210	NC	33uH
EC3SA-12S12	2.2uF/25V 1206	NC	12uH	2.2uF/25V 1210	NC	33uH
EC3SA-12S15	2.2uF/25V 1206	NC	12uH	2.2uF/25V 1210	NC	33uH
EC3SA-12D05	2.2uF/25V 1206	NC	12uH	2.2uF/25V 1210	NC	33uH
EC3SA-12D12	2.2uF/25V 1206	NC	12uH	2.2uF/25V 1210	NC	33uH
EC3SA-12D15	2.2uF/25V 1206	NC	12uH	2.2uF/25V 1210	NC	33uH
EC3SA-24S33	4.7uF/50V 1812	NC	12uH	6.8uF/50V 1812	NC	33uH
EC3SA-24S05	4.7uF/50V 1812	NC	12uH	6.8uF/50V 1812	NC	33uH
EC3SA-24S12	4.7uF/50V 1812	NC	12uH	6.8uF/50V 1812	NC	33uH
EC3SA-24S15	4.7uF/50V 1812	NC	12uH	6.8uF/50V 1812	NC	33uH
EC3SA-24D05	4.7uF/50V 1812	NC	12uH	6.8uF/50V 1812	NC	33uH
EC3SA-24D12	4.7uF/50V 1812	NC	12uH	6.8uF/50V 1812	NC	33uH
EC3SA-24D15	4.7uF/50V 1812	NC	12uH	6.8uF/50V 1812	NC	33uH
EC3SA-48S33	1uF/100V 1812	NC	68uH	2.2uF/100V 1812	NC	150uH
EC3SA-48S05	1uF/100V 1812	NC	68uH	2.2uF/100V 1812	NC	150uH
EC3SA-48S12	1uF/100V 1812	NC	68uH	2.2uF/100V 1812	NC	150uH
EC3SA-48S15	1uF/100V 1812	NC	68uH	2.2uF/100V 1812	NC	150uH
EC3SA-48D05	1uF/100V 1812	NC	68uH	2.2uF/100V 1812	NC	150uH
EC3SA-48D12	1uF/100V 1812	NC	68uH	2.2uF/100V 1812	NC	150uH
EC3SA-48D15	1uF/100V 1812	NC	68uH	2.2uF/100V 1812	NC	150uH

Note: All of capacitors are ceramic capacitors.



EC3SA 3W Isolated DC-DC Converters

Application Note V12 December 2016

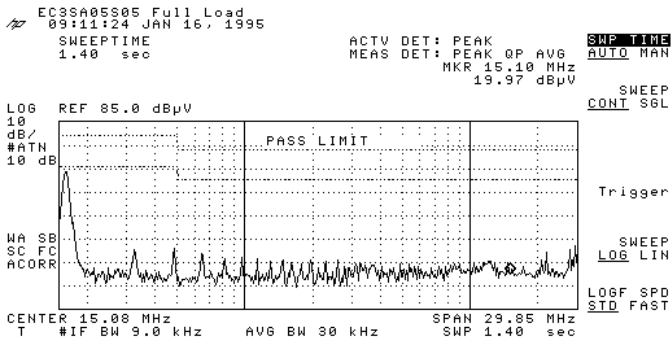

Figure9 Conducted Class A of EC3SA-05S05

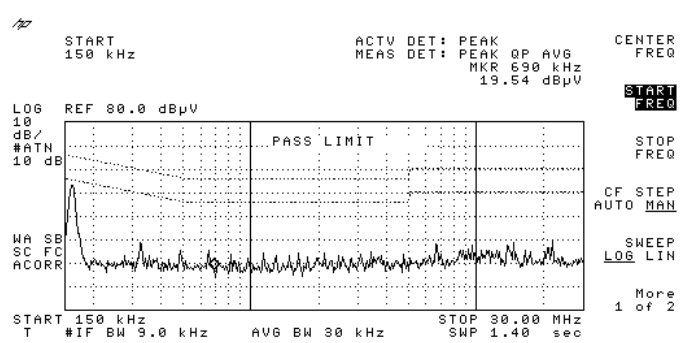

Figure13 Conducted Class B of EC3SA-05S05

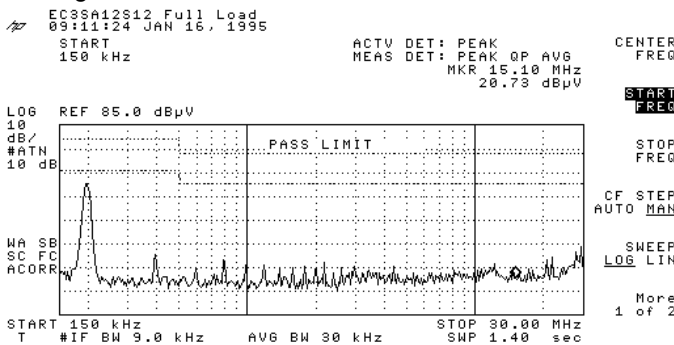

Figure10 Conducted Class A of EC3SA-12S12

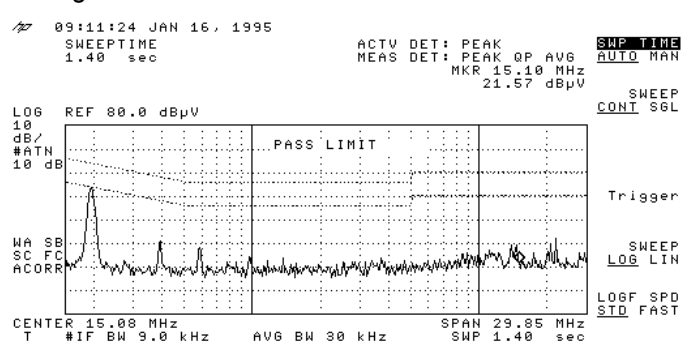

Figure14 Conducted Class B of EC3SA-12D05

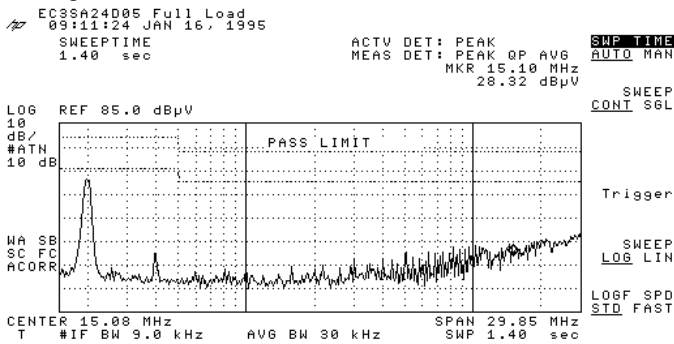

Figure11 Conducted Class A of EC3SA-24D05

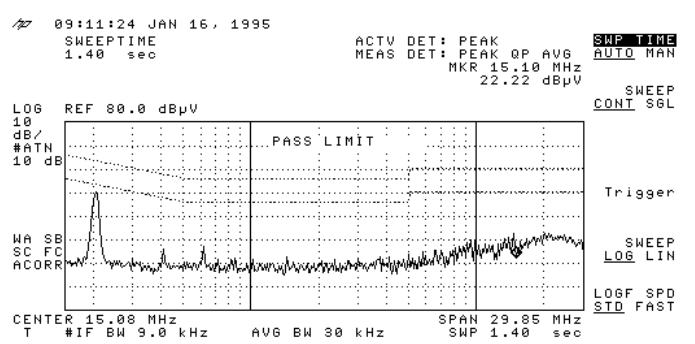

Figure15 Conducted Class B of EC3SA-24S12

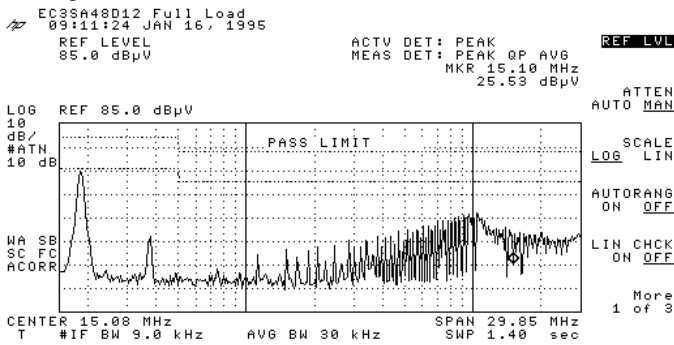

Figure12 Conducted Class A of EC3SA-48D12

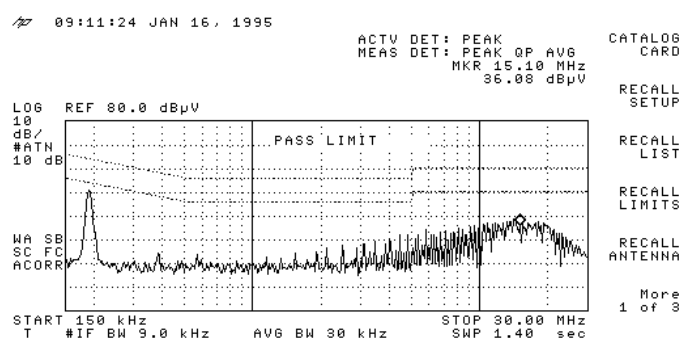

Figure16 Conducted Class B of EC3SA-48D15



EC3SA 3W Isolated DC-DC Converters

Application Note V12 December 2016

8. Part Number

EC3SA – XX S XX N

None: without Under Voltage Protection
N: Under Voltage Protection

EC3SA SERIES

S : Single Output
D : Dual Output

05 : Nominal Input Voltage 5VDC
12 : Nominal Input Voltage 12VDC
24 : Nominal Input Voltage 24VDC
48 : Nominal Input Voltage 48VDC

33 : Output Voltage 3.3 VDC
05 : Output Voltage 5 VDC
12 : Output Voltage 12 VDC
15 : Output Voltage 15 VDC

9. Mechanical Specifications

All Dimensions In Inches(mm)

Tolerances : Inches millimeters

X.XX±0.02 X.X±0.5

Pin ±0.002 ±0.05

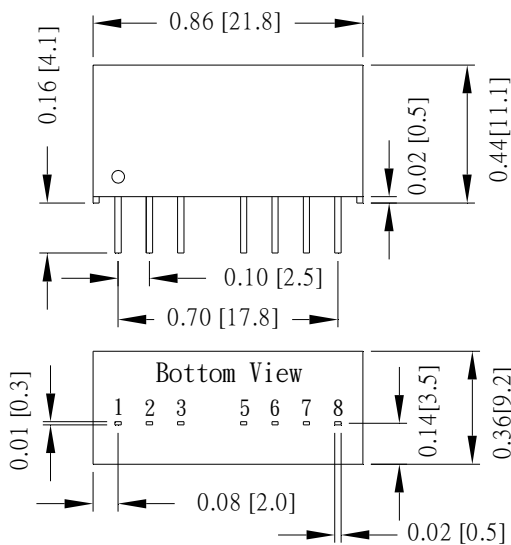

PIN CONNECTION		
Pin	Single	Dual
1	-Vin	-Vin
2	+Vin	+Vin
3	On/Off	On/Off
5	NC	NC
6	+Vo	+Vo
7	-Vo	Common
8	NC	-Vo

CINCON ELECTRONICS CO., LTD.

Headquarter Office:

14F, No.306, Sec.4, Hsin Yi Rd.,
Taipei, Taiwan
Tel: 886-2-27086210
Fax: 886-2-27029852
E-mail: sales@cincon.com.tw
Web Site: <http://www.cincon.com>

Factory:

No. 8-1, Fu Kong Rd.,
Fu Hsing Industrial Park
Fu Hsing Hsiang, ChangHua Hsien,
Taiwan
Tel: 886-4-7690261
Fax: 886-4-7698031

Cincon American Office:

1655 Mesa Verde Ave, Ste 180,
Ventura, CA 93003
Tel: 805-639-3350
Fax: 805-639-4101
E-mail: info@cincon.com