



# FM10/20-100 DC FILTER MODULE

## Application Note V10 December 2019

### FM10/20-100 DC FILTER MODULE



#### Approved By:

Department	Approved By	Checked By	Written By
Research and Development Department	Enoch	Danny	Johnny
		Jacky	
Quality Assurance Department	Ryan	Benny	



# FM10/20-100 DC FILTER MODULE

## Application Note V10 December 2019

---

### Content

<b>1. INTRODUCTION</b>	<b>3</b>
<b>3. ELECTRICAL CIRCUIT DIAGRAM</b>	<b>3</b>
<b>4. TECHNICAL SPECIFICATIONS</b>	<b>4</b>
<b>5. MAIN FEATURES AND FUNCTIONS</b>	<b>5</b>
5.1 Operating Temperature Range	5
5.2 Insertion Loss	5
<b>6. APPLICATIONS</b>	<b>5</b>
6.1 Recommend Layout, PCB Footprint and Soldering Information	5
6.2 Thermal Considerations	6
6.3 Power Derating	6
<b>7. CONNECTION FOR STANDARD USE</b>	<b>7</b>
<b>8. PART NUMBER</b>	<b>13</b>
<b>9. MECHANICAL OUTLINE DIAGRAMS</b>	<b>13</b>
9.1 Mechanical Outline Diagrams	13



# FM10/20-100 DC FILTER MODULE

## Application Note V10 December 2019

### 1. Introduction

FM10/20-100 filter module is created to accommodate the need to meet ITE EN55032 standard. This standard filter simplifies the process of meeting the necessary requirements for the application of EN55032 EMI solutions. The filter module is designed to reduce common mode and differential mode noise of the DC converter. The FM10/20-100 filter module offers maximum current rating of 10A/20A with Derating and maximum input voltage up to 75V.

It has Compact Size 2"x1", 2"x1.6" size and pinouts. Allowing case operating temperature range of -40°C to 100°C. FM10 / 20-100 is mainly designed for distributed power architecture, telecommunications, battery-powered equipment and industrial applications.

### 2. Features

- \* Compact Size 2"x1", 2"x1.6"
- \* PCB Mount
- \* 10A and 20A Filter Module
- \* 75VDC Input Voltage Maximum
- \* Suitable for use with Half Brick and Quarter Brick Series
- \* All Capacitors are Multi-Layer Ceramic Inside

### 3. Electrical Circuit Diagram

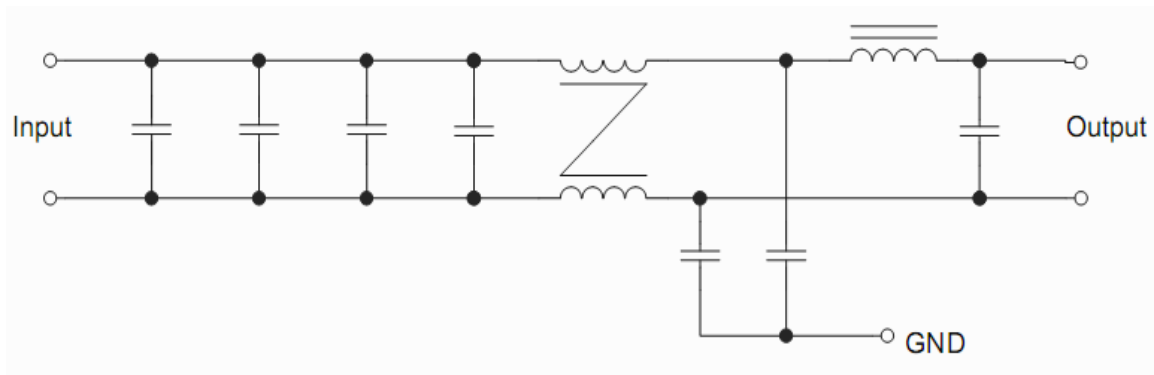

Figure1 Internal Schematic for FM10-100 Module

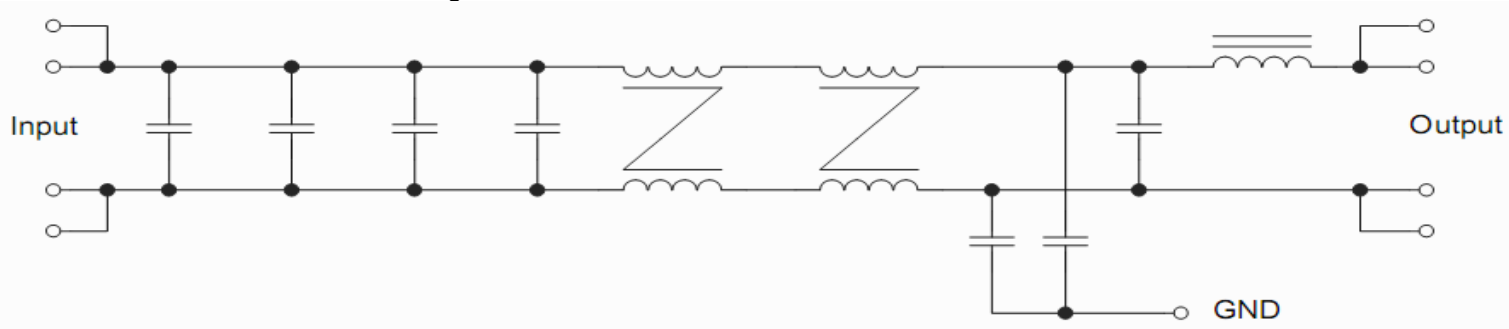

Figure2 Internal Schematic for FM20-100 Module



# FM10/20-100 DC FILTER MODULE

## Application Note V10 December 2019

### 4. Technical Specifications

(All specifications are typical at nominal input, full load at 25°C unless otherwise noted.)

#### ABSOLUTE MAXIMUM RATINGS

PARAMETER	NOTES and CONDITIONS	Device	Min.	Typical	Max.	Units
Input Voltage						
Continuous		All			75	V <sub>dc</sub>
Transient	100ms	All			100	V <sub>dc</sub>
Operating Case Temperature	With derating <b>See 6.3</b>	All	-40		+100	°C
Storage Temperature		All	-55		+105	°C

#### ELECTRICAL CHARACTERISTICS

PARAMETER	NOTES and CONDITIONS	Device	Min.	Typical	Max.	Units
Operating Voltage Range		All	0		75	V <sub>dc</sub>
Operating Current Range	With derating <b>See 6.3</b>	FM10-100	0		10	A
		FM20-100	0		20	A
Input Surge Voltage	100ms	All			100	V <sub>dc</sub>
DC Resistance	+Input to +Output	FM10-100		11.5		mΩ
		FM20-100		9.5		
	-Input to -Output	FM10-100		4.5		mΩ
		FM20-100		5.7		

#### ISOLATION CHARACTERISTICS

PARAMETER	NOTES and CONDITIONS	Device	Min.	Typical	Max.	Units
Isolation Voltage	1 minute: input to GND	All			1500	V <sub>dc</sub>
	1 minute: output to GND				500	V <sub>dc</sub>
Isolation Resistance	500Vdc, input to case, output to case	All	10			MΩ
Isolation Capacitance	input to GND, output to GND	All		940		pF

#### GENERAL SPECIFICATIONS

PARAMETER	NOTES and CONDITIONS	Device	Min.	Typical	Max.	Units
Weight		FM10-100		30		grams
		FM20-100		55		
Case Material	Plastic, DAP					
Potting Material	UL 94V-0					
Shock/Vibration	Meets EN61373					
Humidity	95% RH max. Non Condensing					
Thermal Shock	Meets MIL-STD-810F					



# FM10/20-100 DC FILTER MODULE

## Application Note V10 December 2019

### 5. Main Features and Functions

#### 5.1 Operating Temperature Range

The FM10/20-100 filter module has resulted in their ability to operate within ambient temperature environments from -40°C to 100°C. The derating curve was drawn from the FM10/20-100 module.

- Output load current
- Forced air or natural convection

#### 5.2 Insertion Loss

The filter module is designed to reduce common mode and differential mode noise of the DC converter. The typical characteristics see below.

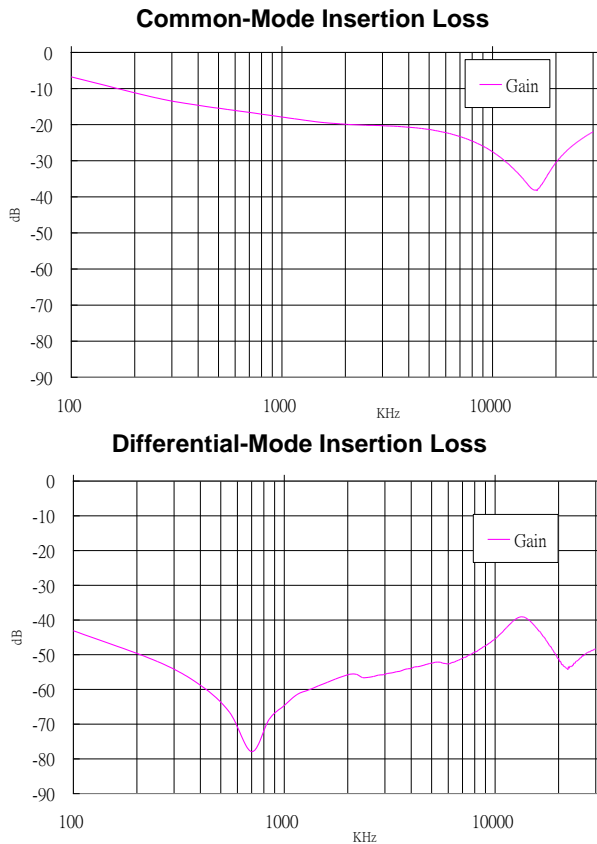

Figure 2. Typical Common-mode and Differential-mode Loss for FM10-100

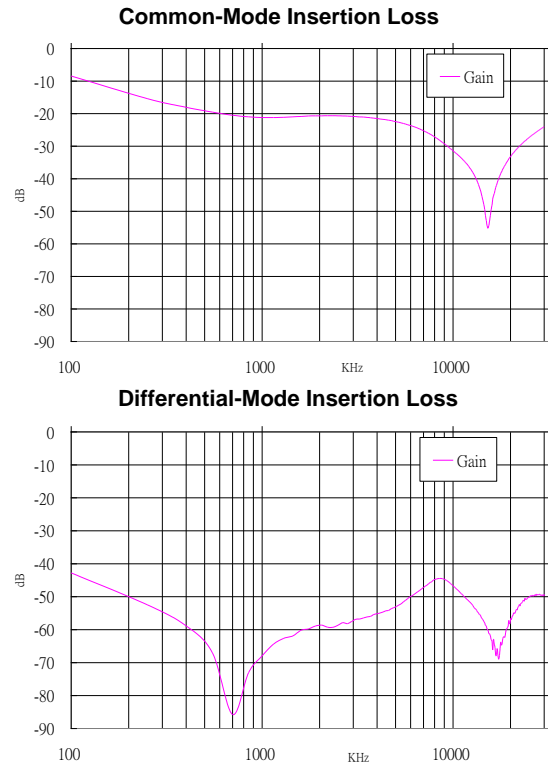

Figure 3. Typical Common-mode and Differential-mode Loss for FM20-100

### 6. Applications

#### 6.1 Recommend Layout, PCB Footprint and Soldering Information

The system designer or end user must ensure that metal and other components in the vicinity of the module meet the spacing requirements for which the system is approved. Low resistance and inductance PCB layout traces are the norm and should be used where possible. Due consideration must also be given to proper low impedance tracks between power module, input and output grounds. The recommended soldering profile and PCB layout are shown below.

Lead Free Wave Soldering Profile

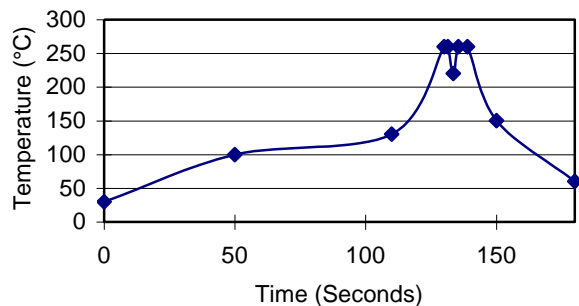



# FM10/20-100 DC FILTER MODULE

## Application Note V10 December 2019

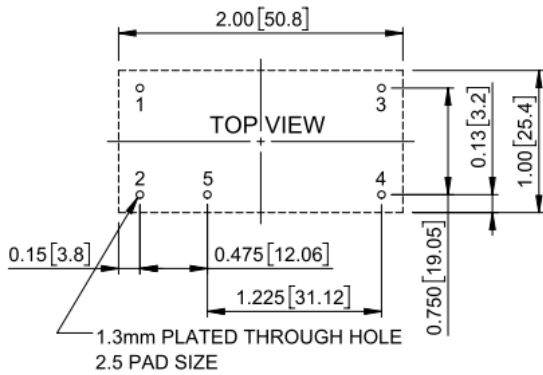

FM10-100 PCB Footprint

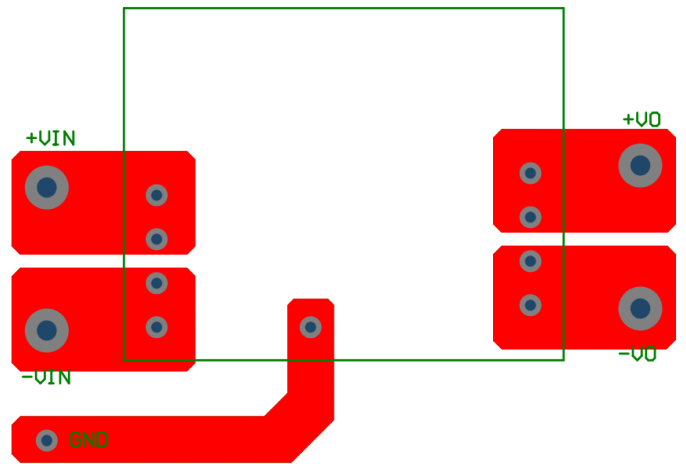

FM20-100 Suggested PCB Layout

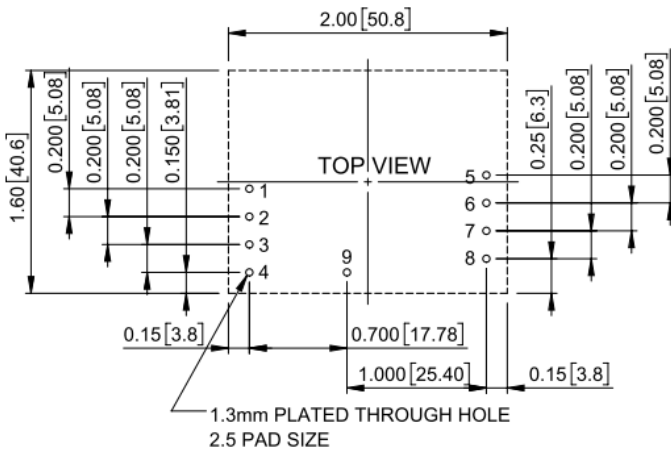

FM10-100 PCB Footprint

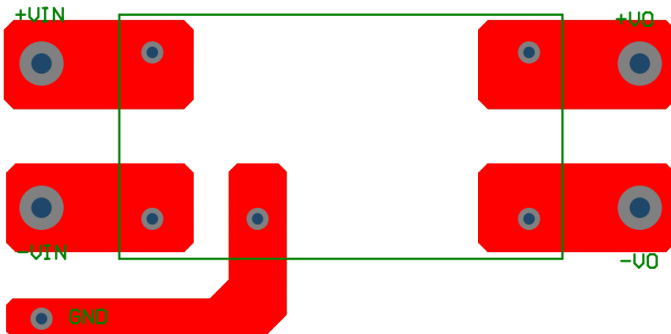

FM10-100 Suggested PCB Layout

### 6.2 Thermal Considerations

The module operates in a variety of thermal environments; however, sufficient cooling should be provided to help ensure reliable operation of the unit. Heat is removed by conduction, convection, and radiation to the surrounding environment. The example is presented in **section 6.3**. The current output of the module should not be allowed to exceed rated current.

### 6.3 Power Derating

The operating case temperature range of FM10/20-100 is -40°C to +100°C. When operating the FM10/20-100, proper derating or cooling is needed. The maximum case temperature under any operating condition should not exceed 100°C.

The following curve is the de-rating curve of FM10/20-100

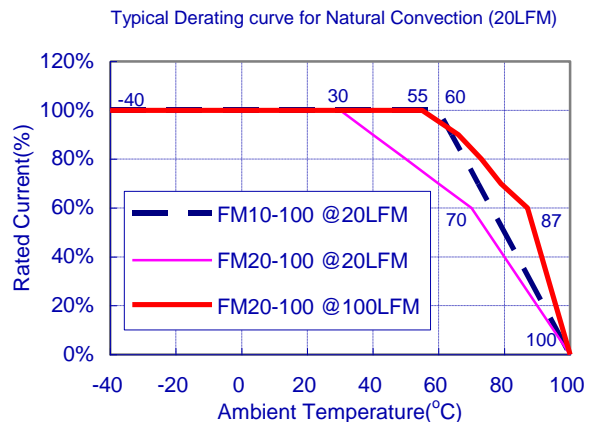



# FM10/20-100 DC FILTER MODULE

## Application Note V10 December 2019

### 7. Connection for Standard Use

#### 7.1 Recommended Schematic

EMI performance is affected by a variety of external factors, such as PCB construction, circuit layout, and more. Therefore, in some applications, components other than filters may be required to fully comply with the specified standards. For ITE application, the FM10/20-100 input filter is required for input conducted noise to meet EN55032.

The Filter Module have no internal fuse. In order to achieve maximum safety and system protection, always use an input line fuse. please evaluate the appropriate fuse with Converter.

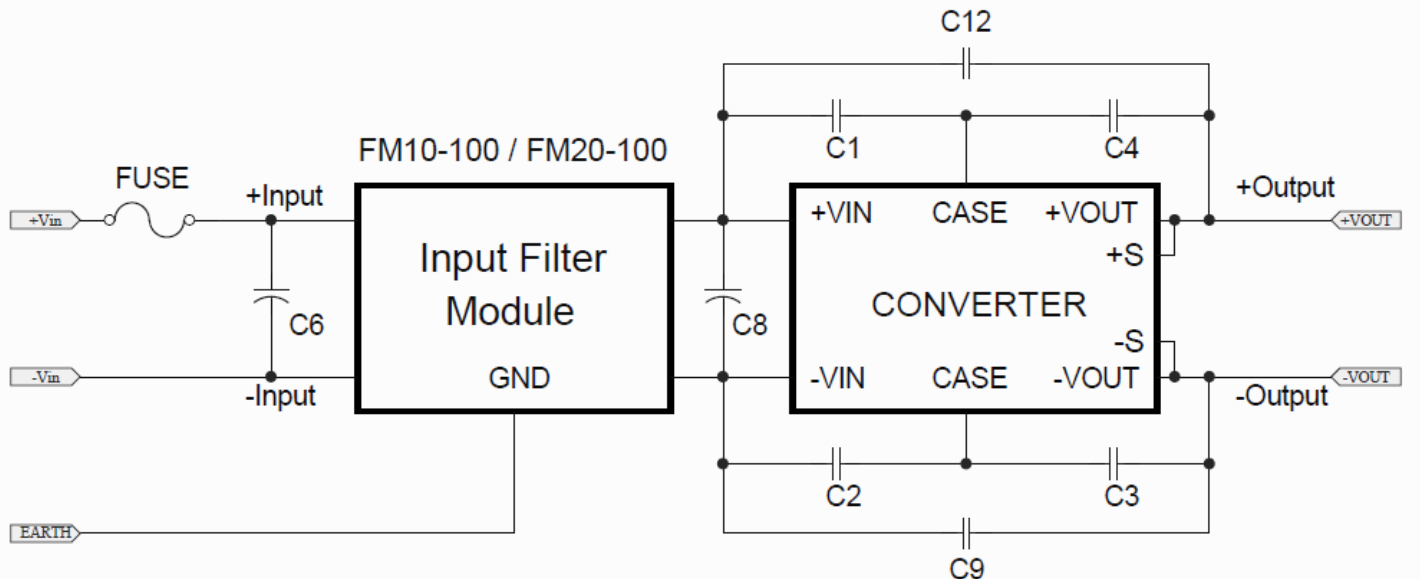

Note:

C1-C4 & C9-C12 Select the voltage rating to meet input-to-output isolation requirements.

Note:

If the impedance of input line is high, Input capacitance must be more than above. Use more than two recommended capacitor above in parallel when ambient temperature becomes lower than  $-20^{\circ}\text{C}$



# FM10/20-100 DC FILTER MODULE

## Application Note V10 December 2019

### 7.2 EMC Considerations

EMI Test standard: EN55032 Class A Conducted Emission

Test Condition: Input Voltage: Nominal, Output Load: Full Load

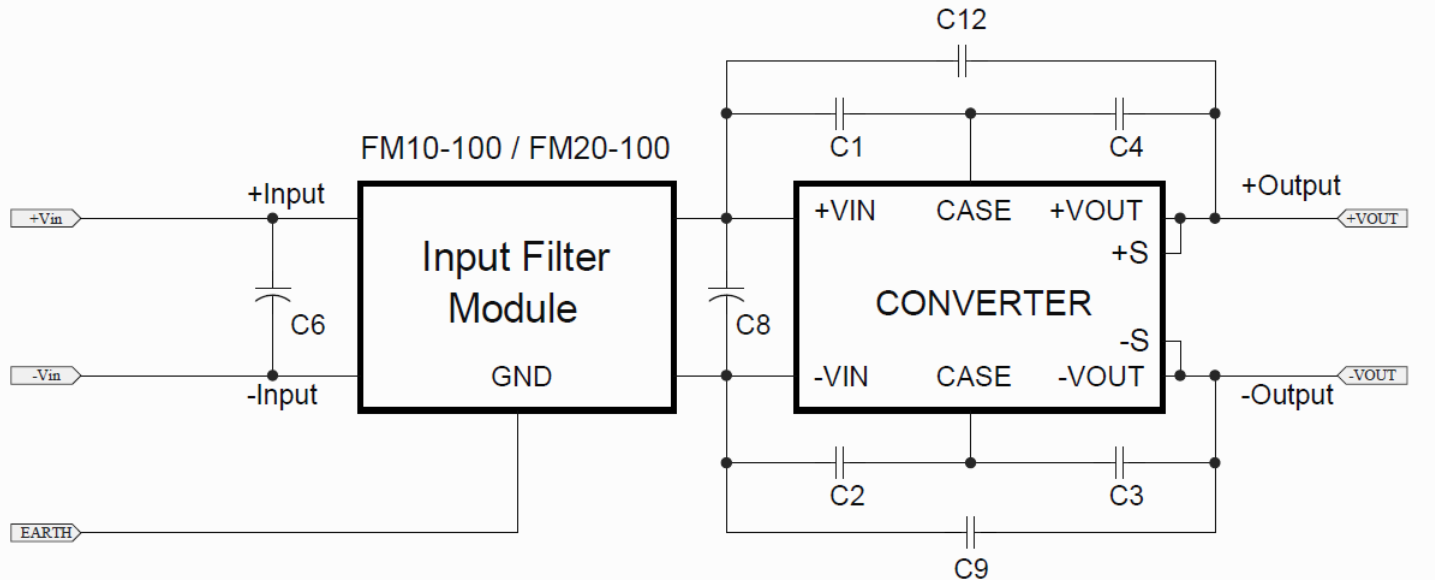

Figure1 Connection circuit for conducted EMI Class A testing





# FM10/20-100 DC FILTER MODULE

## Application Note V10 December 2019

Input Filter Module	DC-DC Converter Model No.	C1	C2	C3	C4	C6	C8	C9	C12
FM10-100	CQE50W-24S12	NC	NC	NC	NC	47uF	47uF	1000pF	1000pF
FM10-100	CQB75W-48S15	NC	NC	NC	NC	47uF	47uF	1000pF	1000pF
FM10-100	CHB50W-48S12	NC	NC	NC	NC	47uF	47uF	1000pF	1000pF
FM10-100	CHB75-48S15	NC	NC	NC	NC	47uF	47uF	1000pF	1000pF
FM10-100	CHB75W-24S12	NC	NC	NC	NC	47uF	47uF	1000pF	1000pF
FM10-100	CHE75W-48S05	NC	NC	NC	NC	47uF	47uF	1000pF	1000pF
FM10-100	CHB100-48S12	1000pF	1000pF	1000pF	1000pF	47uF	47uF	1000pF	1000pF
FM10-100	CHB100W-48S15	NC	NC	NC	NC	47uF	47uF	1000pF	1000pF
FM10-100	CHE100W-48S12	NC	NC	NC	NC	47uF	47uF	1000pF	1000pF
FM10-100	CHB150W-48S48	NC	NC	NC	NC	47uF	47uF	1000pF	1000pF
FM20-100	CHB200-24S05	NC	NC	NC	NC	470uF	470uF	1000pF	1000pF
FM20-100	CHB200W-48S05	NC	NC	NC	NC	470uF	470uF	1000pF	1000pF
FM20-100	CHB300W-48S12	NC	NC	NC	NC	470uF	470uF	1000pF	1000pF
FM20-100	CHB350-48S24	1000pF	1000pF	1000pF	1000pF	470uF	470uF	1000pF//1000pF	1000pF//1000pF

Note: C6, C8 are (47uF/100V KY Series , 470uF/100V PW(M) Series)aluminum capacitors,  
 C1, C2, C3, C4, C9, C12 Select the voltage rating to meet input-to-output isolation requirements.



# FM10/20-100 DC FILTER MODULE

## Application Note V10 December 2019

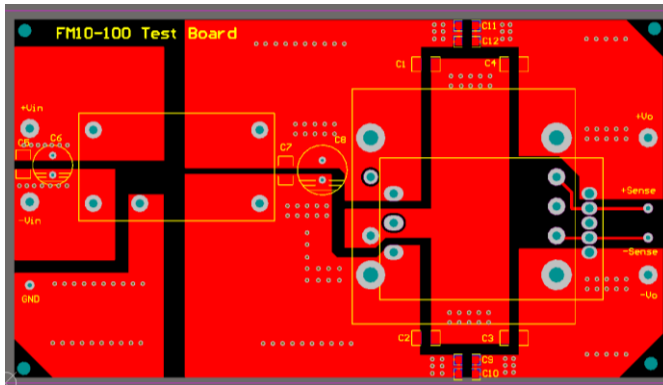

FM10-100 Test Board

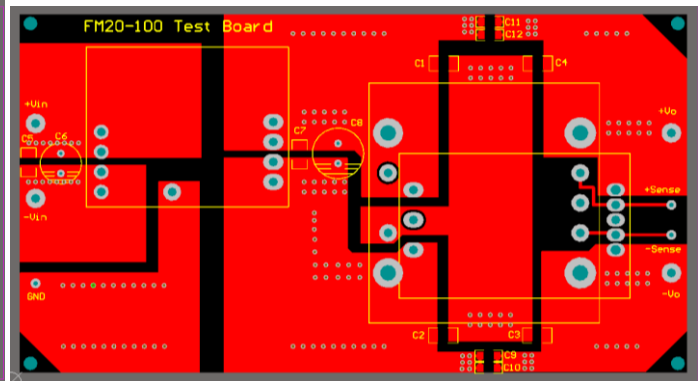

FM20-100 Test Board

EMI test board top side

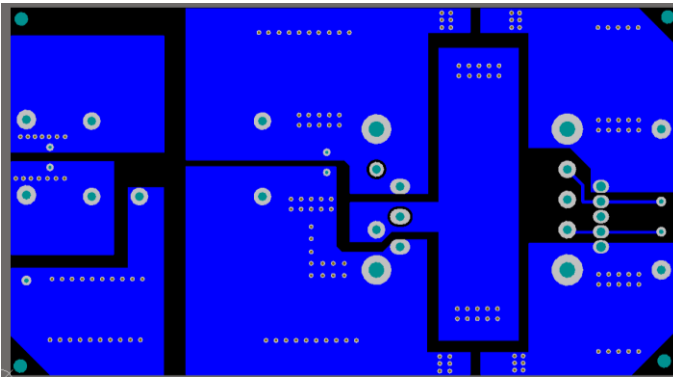

FM10-100 Test Board

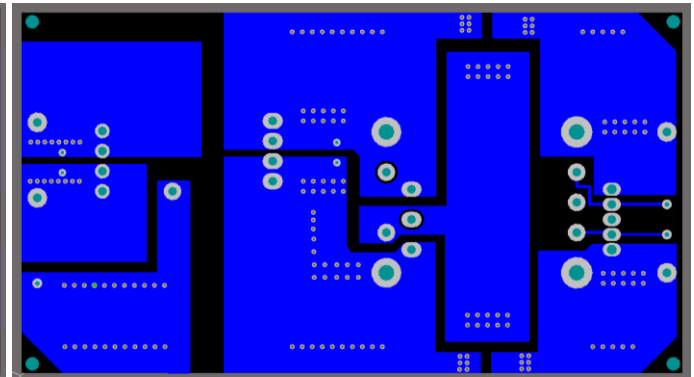

FM20-100 Test Board

EMI test board bottom side



# FM10/20-100 DC FILTER MODULE

## Application Note V10 December 2019

(1) EMI input conducted noise to meet EN55032:

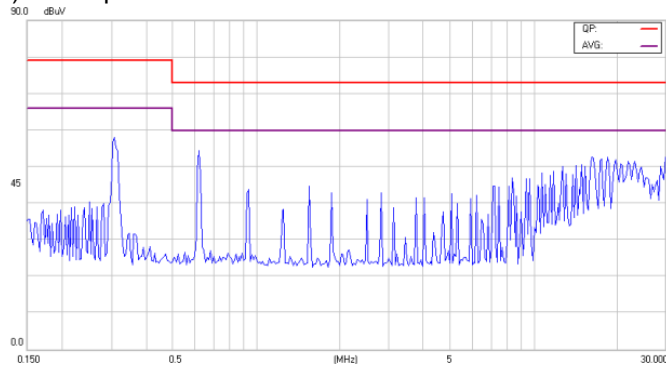

Conducted EN55032 Class A of CQE50W-24S12

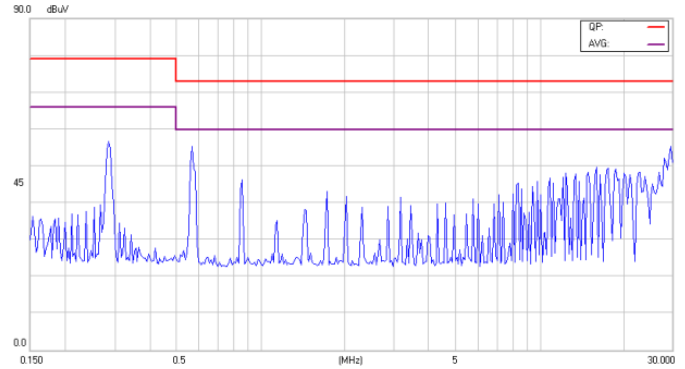

Conducted EN55032 Class A of CQB75W-48S15

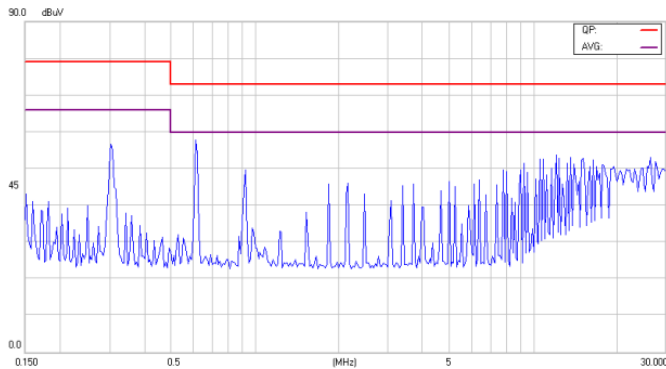

Conducted EN55032 Class A of CHB50W-48S12

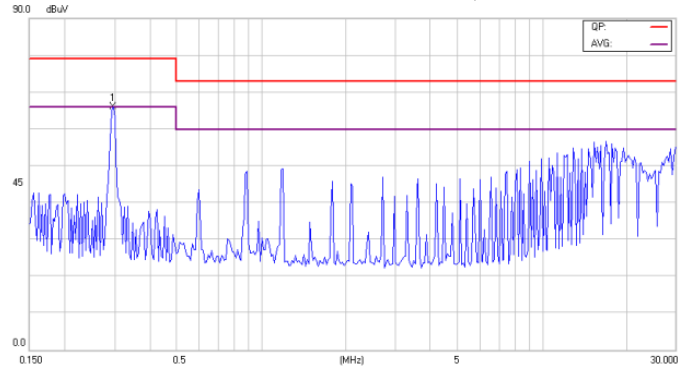

Conducted EN55032 Class A of CHB75-48S15

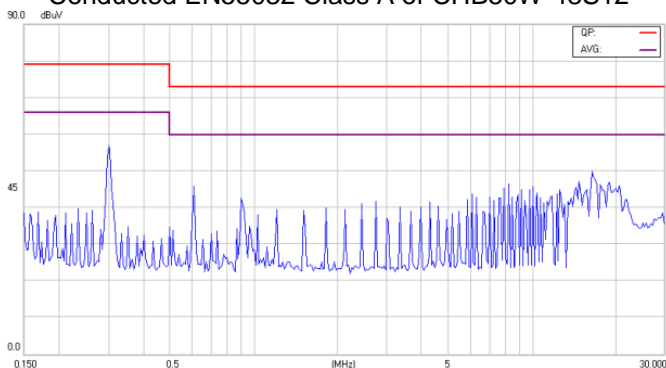

Conducted EN55032 Class A of CHB75W-24S12

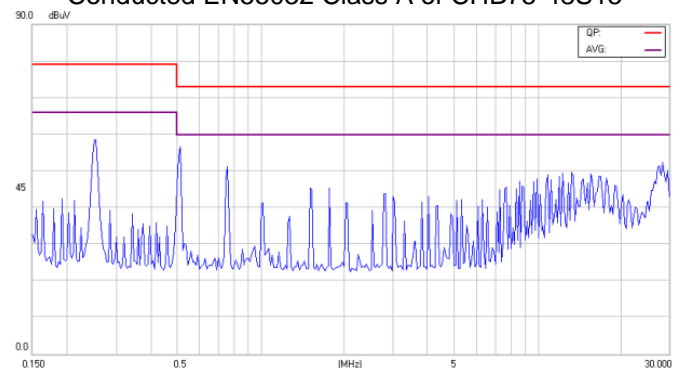

Conducted EN55032 Class A of CHE75W-48S05

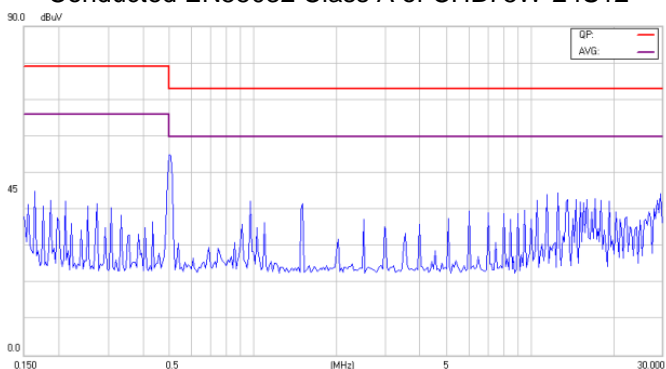

Conducted EN55032 Class A of CHB100-48S12



Conducted EN55032 Class A of CHB100W-48S15



# FM10/20-100 DC FILTER MODULE

## Application Note V10 December 2019

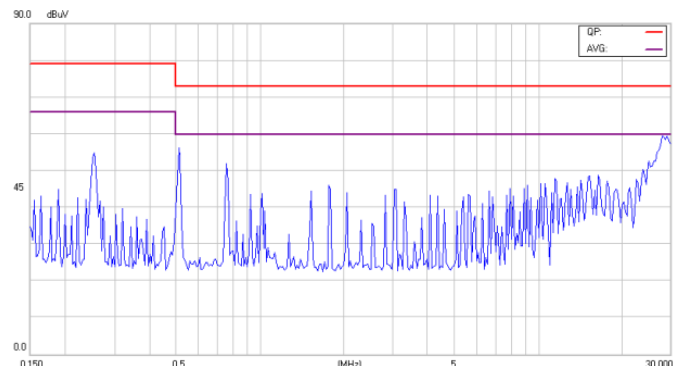

Conducted EN55032 Class A of CHE100W-48S12

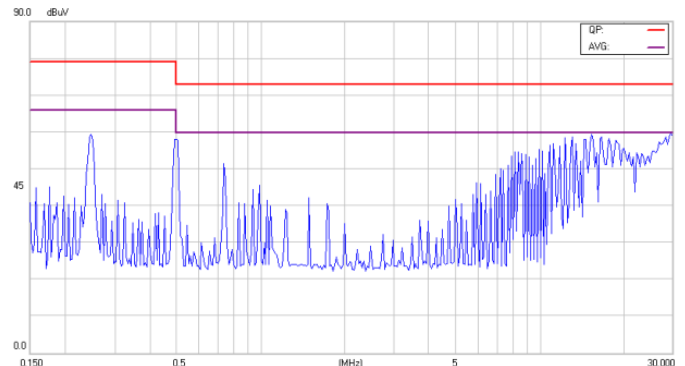

Conducted EN55032 Class A of CHB150W-48S48

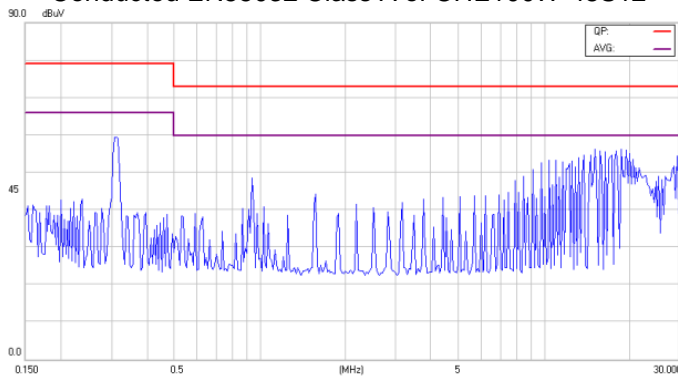

Conducted EN55032 Class A of CHB200-24S05

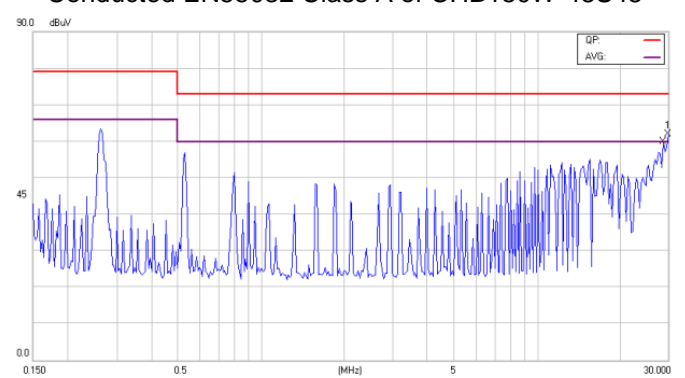

Conducted EN55032 Class A of CHB200W-48S05

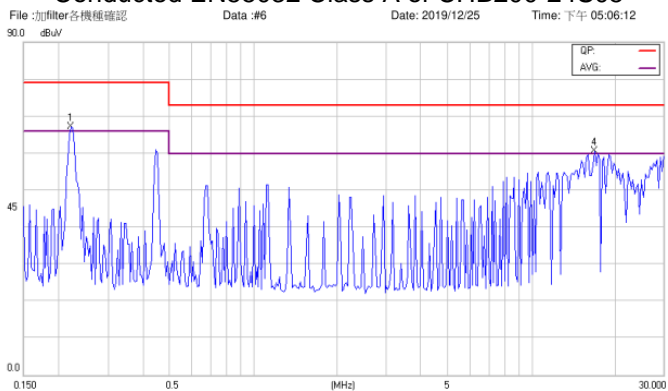

Conducted EN55032 Class A of CHB300W-48S12

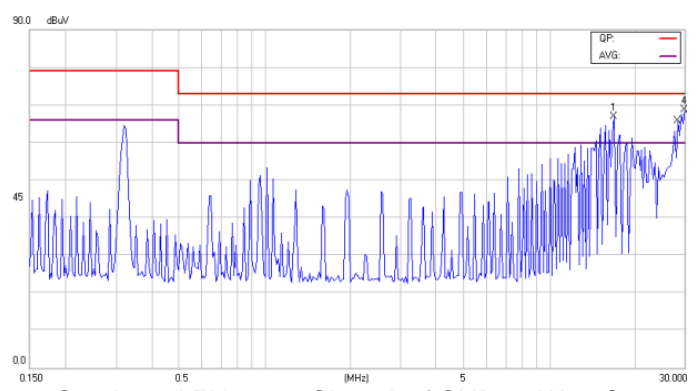

Conducted EN55032 Class A of CHB350W-48S24



# FM10/20-100 DC FILTER MODULE

## Application Note V10 December 2019

### 8. Part Number

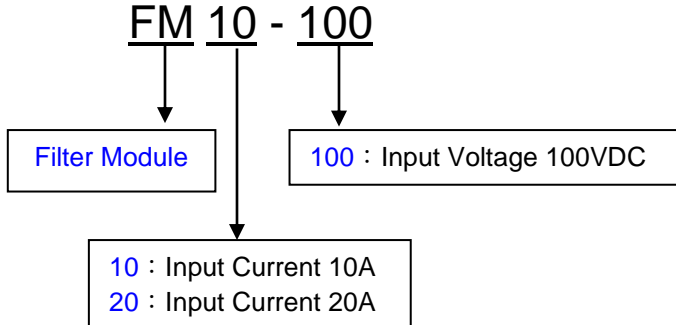

### 9. Mechanical Outline Diagrams

#### 9.1 Mechanical Outline Diagrams

**DIMENSIONS:**  
 NOTE: Pin Size is 0.04" Inch (1.02mm) DIA  
 All Dimensions In Inches (mm)  
 Tolerances Inches: X.XX= ±0.02 , X.XXX= ±0.010  
 Millimeters: X.X= ±0.5 , X.XX= ±0.25

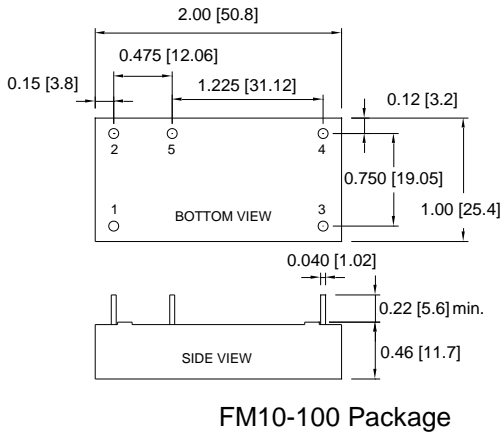

PIN CONNECTION	
Pin	Function
1	+V Input
2	-V Input
3	+V Output
4	-V Output
5	GND

**DIMENSIONS:**  
 NOTE: Pin Size is 0.04" Inch (1.02mm) DIA  
 All Dimensions In Inches (mm)  
 Tolerances Inches: X.XX= ±0.02 , X.XXX= ±0.010  
 Millimeters: X.X= ±0.5 , X.XX= ±0.25

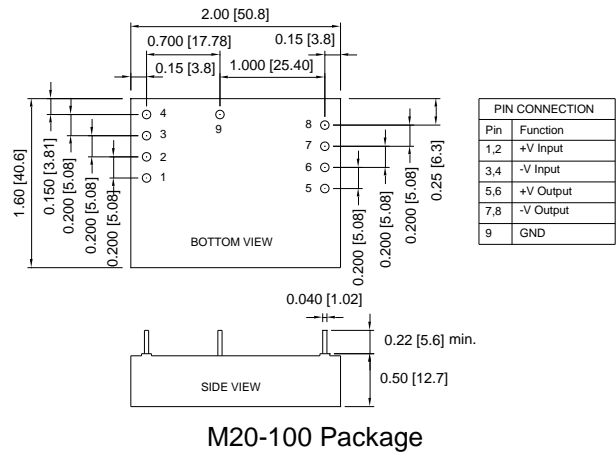

PIN CONNECTION	
Pin	Function
1,2	+V Input
3,4	-V Input
5,6	+V Output
7,8	-V Output
9	GND

F

### CINCON ELECTRONICS CO., LTD.

#### Headquarters:

14F, No.306, Sec.4, Hsin Yi Rd.  
 Taipei, Taiwan  
 Tel: 886-2-27086210  
 Fax: 886-2-27029852  
 E-mail: [support@cincon.com.tw](mailto:support@cincon.com.tw)  
 Web Site: <http://www.cincon.com>

#### Factory:

No. 8-1, Fu Kung Rd.  
 Fu Hsing Industrial Park  
 Fu Hsing Hsiang,  
 Chang Hua Hsien, Taiwan  
 Tel: 886-4-7690261  
 Fax: 886-4-7698031

#### Cincon North America:

1655 Mesa Verde Ave. Ste 180  
 Ventura, CA 93003  
 Tel: 805-639-3350  
 Fax: 805-639-4101  
 E-mail: [info@cincon.com](mailto:info@cincon.com)